

1ST PRINTING JULY 01

# SEGA

# STAR WARS RACER ARCADE

Deluxe Version

## OWNER'S MANUAL



SEGA ENTERPRISES, INC. USA

MANUAL NO. 420-6575-01

# VISIT OUR WEBSITE!

SegaService.com

Address: <http://www.seuservice.com/>

Apple Central.Sega.com Sega.com SegaService.com Yahoo! Yahoo! Maps and Driving Directions

**SEGA SERVICE**

  
**Ask Dave!**

- [what's new](#)
- [manuals](#)
- [bulletins](#)
- [assemblies](#)
- [Search](#)

---

- [bulletin Sign-up](#)
- [register game](#)

---

- [staff](#)
- [Darl's Office](#)
- [tech. service](#)
- [warranty policy](#)

---

- [corporate info](#)
- [home page](#)
- [future technologies](#)
- [plugins](#)
- [non-framed page](#)

Sega Enterprises Inc.,  
USA  
Service Department  
phone 415.701.6580  
fax 415.701.6594



**5564** people have visited this page since 3/16/01

If you have any questions or comments  
about this site please E-Mail to [Darl.Davidson@seu.sega.com](mailto:Darl.Davidson@seu.sega.com)

THIS WEB SITE POWERED BY  
**WebSTAR 4.3** Mac OS

[\[what's new\]](#)[\[manuals\]](#)[\[bulletins\]](#)[\[assemblies\]](#)[\[Search\]](#)[\[staff\]](#)[\[Darl's office\]](#)  
[\[technical service\]](#)[\[customer service\]](#)[\[corporate info\]](#)[\[plugins\]](#)[\[Non-framed page\]](#)

You will need the following items to view this page in its entirety.

 **Get Acrobat Reader**  **Microsoft Internet Explorer**  **Microsoft Internet Explorer**

All Platforms Windows Macintosh

Internet zone

## **BEFORE USING THE PRODUCT, BE SURE TO READ THE FOLLOWING:**

### **To maintain the safety:**

To ensure the safe usage of the product, be sure to read the following before using the product. The following instructions are intended for the users, operators and the personnel in charge of the operation of the product. After carefully reading and sufficiently understanding the warning displays and cautions, handle the product appropriately. Be sure to keep this manual nearby the product or elsewhere convenient for referring to it when necessary.

Herein, explanations which require special attention are enclosed with dual lines. Depending on the potentially hazardous degrees, the terms of WARNING, CAUTION, etc. are used. Be sure to understand the contents of the displays before reading the text.



**WARNING!**

Indicates that mishandling the product by disregarding this warning will cause a potentially hazardous situation which can result in death or serious injury.



**CAUTION!**

Indicates that mishandling the product by disregarding this caution will cause a slight hazardous situation which can result in personal injury and or material damage.

### **For the safe usage of the product, the following pictographs are used:**



Indicates “HANDLE WITH CARE.” In order to protect the human body and equipment, this display is attached to places where the Owner’s Manual and or Service Manual should be referred to.

#### **○ Perform work in accordance with the instructions herein stated.**

Instructions for work are explained by paying attention to the aspect of accident prevention. Failing to perform work as per the instructions can cause accidents. In the case where only those who have technical expertise should perform the work to avoid hazardous situation, the instructions herein state that the serviceman should perform such work.

#### **○ Be sure to turn off power before working on the machine.**

To prevent electric shock, be sure to turn off power before starting the work in which the worker touches the interior of the product. If the work is to be performed in the power-on status, the Instruction Manual herein always states to that effect.

#### **○ Be sure to ground the Earth Terminal (this, however, is not required in the case where a power cord with earth is used).**

This product is equipped with the Earth Terminal. When installing the product, Connect the Earth Terminal to the “accurately grounded indoor earth terminal” by using an earth wire. Unless the product is grounded appropriately, the user can be subject to electric shock. After performing repair, etc. for the Control equipment, ensure that the Earth Wire is firmly connected to the Control equipment.

#### **○ Ensure that the Power Supply used is equipped with an Earth Leakage Breaker.**

This product does not incorporate the Earth Leakage Breaker. Using a power supply which is not equipped with the Earth Leakage Breaker can cause a fire when earth leakage occurs.

#### **○ Be sure to use fuses which meet the specified rating. (only for the machines which use fuses).**

Using fuses exceeding the specified rating can cause a fire and electric shock.

○ **Specification changes (removal of equipment, conversion and addition) not designated by SEGA are not allowed.**

The parts of the product include warning labels for safety, covers for personal protection, etc. It is very hazardous to operate the product by removing parts and or modifying the circuits. Should doors, lids and protective parts be damaged or lost, refrain from operating the product, and contact where the product was purchased from or the office herein stated. SEGA shall not be held responsible for any accidents, compensation for damage to a third party, resulting from the specifications not designated by SEGA.

○ **Ensure that the product meets the requirements of appropriate Electrical Specifications.**

Before installing the product, check for Electrical Specifications. SEGA products have a nameplate on which Electrical Specifications are described. Ensure that the product is compatible with the power supply voltage and frequency requirements of the location. Using any Electrical Specifications different from the designated Specifications can cause a fire and electric shock.

○ **Install and operate the product in places where appropriate lighting is available, allowing warning labels to be clearly read.**

To ensure safety for the customers, labels and printed instructions describing potentially hazardous situation are applied to places where accidents can be caused. Ensure that where the product is operated has sufficient lighting allowing the warnings to be read. If any label is peeled off, apply it again immediately. Please place an order with where the product was purchased from or the office herein stated.

○ **When handling the Monitor, be very careful. (Applies only to the product w/monitor.)**

Some of the monitor (TV) parts are subject to high tension voltage. Even after running off power, some portions are still subject to high tension voltage sometimes. Monitor repair and replacement should be performed only by those technical personnel who have knowledge of electricity and technical expertise.

○ **Be sure to adjust the monitor (projector) properly. (Applies only to the product w/monitor.)**

Do not operate the product leaving on-screen flickering or blurring as it is. Using the product with the monitor not properly adjusted may cause dizziness or a headache to an operator, a player, or the customers.

○ **When transporting or reselling this product, be sure to attach this manual to the product.**

In the case where commercially available monitors and printers are used in this product, only the contents relating to this product are explained herein. Some commercially available equipment has functions and reactions not stated in this manual. Read this manual together with the specific Instruction Manual of such equipment.

- Descriptions herein contained may be subject to improvement changes without notice.
- The contents described herein are fully prepared with due care. However, should any question arise or errors be found, please contact SEGA.

**INSPECTIONS IMMEDIATELY AFTER TRANSPORTING THE PRODUCT TO THE LOCATION.**

Normally, at the time of shipment, SEGA products are in a status allowing for usage immediately after transporting to the location. Nevertheless, an irregular situation may occur during transportation. Before turning on power, check the following points to ensure that the product has been transported in a satisfactory status.

- Are there any dented portions or defects (cuts, etc.) on the external surfaces of the cabinet?
- Are Casters and Adjusters, damaged?
- Do the power supply voltage and frequency requirements meet with those of the location?
- Are all wiring connectors correctly and securely connected? Unless connected in the correct direction, connector connections can not be made accurately. Do not insert connectors forcibly.
- Do power cords have cuts and dents?
- Do the fuses used meet specified rating? Is the Circuit Protector in an energized status?
- Are all accessories available?
- Can all Doors and Lids be opened with the Accessory keys? Can Doors and Lids be firmly closed?

---

---

## TABLE OF CONTENTS

---

---

BEFORE USING THE PRODUCT, BE SURE TO READ THE FOLLOWING:

### TABLE OF CONTENTS

#### INTRODUCTION OF THE OWNER'S MANUAL

1. HANDLING PRECAUTIONS .....	1
2. PRECAUTIONS CONCERNING INSTALLATION LOCATION .....	2 - 3
3. OPERATION .....	4 - 6
4. NAME OF PARTS .....	7
5. ACCESSORIES .....	8 - 10
6. ASSEMBLING AND INSTALLATION .....	11 - 26
7. PRECAUTIONS TO BE HEDED WHEN MOVING THE MACHINE .....	27 - 28
8. CONTENTS OF GAME .....	29 - 36
9. EXPLANATION OF TEST AND DATA DISPLAY .....	37 - 38
9 - 1 SWITCH UNIT AND COIN METER .....	39 - 40
9 - 2 SYSTEM TEST MODE .....	41 - 54
9 - 3 GAME TEST MODE .....	55 - 62
10. CONTROL PANEL.....	63
10 - 1 REMOVING THE CONTROL PANEL COVER.....	64 - 65
10 - 2 VOLUME ADJUSTMENT / REPLACEMENT.....	66 - 67
10 - 3 GREASING.....	68 - 69
11. COIN SELECTOR .....	70 - 73
12. PROJECTOR.....	74
12 - 1 CLEANING THE SCREEN.....	74
12 - 2 ADJUSTMENT OF PROJECTOR.....	75 - 84
13. REPLACING THE FLOURESCENT LAMP, AND LAMPS .....	85 - 86
14. PERIODIC INSPECTION TABLE .....	87 - 88
15. TROUBLESHOOTING .....	89 - 90
16. GAME BOARD .....	91
16 - 1 REMOVING THE GAME BOARD .....	92 - 94
16 - 2 COMPOSITION OF GAME BOARD .....	95
17. DESIGN RELATED PARTS .....	96
18. COMMUNICATION PLAY.....	97
18 - 1 INSTALLATION PRECAUTIONS.....	97 - 98
18 - 2 CONNECTING THE COMMUNICION CABLE.....	98 - 102
18 - 3 SETTING FOR COMMUNICATION PLAY.....	103 - 104
18 - 4 CAUTIONS TO BE HEDED DUKRING COMUNICATION PLAY.....	104
19. PARTS LIST .....	105 - 149
20. WIRE COLOR CODE TABE .....	150
21. WIRING DIAGRAM .....	151 - 153

---

---

## SPECIFICATIONS

Installation Space	: 1,310 mm (W) X 2,830 mm (D) (51.6 in. X 111.4 in.)
Height	: 2,660 mm (104.7 in.)
Weight	: 370 kg. (815.7 lbs.)
Power, maximum current	: 600 W 6.7 A (AC 110V 50 Hz AREA) 600 W 6.7 A (AC 110V 60 Hz AREA) 580 W 6.0 A (AC 120V 60 Hz AREA) 590 W 3.5 A (AC 220V 50 Hz AREA) 580 W 3.4 A (AC 220V 60 Hz AREA) 600 W 3.4 A (AC 230V 50 Hz AREA) 580 W 3.2 A (AC 230V 60 Hz AREA) 600 W 3.2 A (AC 240V 50 Hz AREA) 590 W 3.2 A (AC 240V 60 Hz AREA)
For TAIWAN	
Power, current	: 600 W 6.7 A (MAX.) 340 W 4.0 A (MIN.)
MONITOR	: 50 TYPE COLOR MONITOR

## INTRODUCTION OF THE OWNERS MANUAL

This Owner's Manual is intended to provide detailed descriptions together with all the necessary information covering the general operation of electronic assemblies, electromechanicals, servicing control, spare parts, etc. as regards the product, **STAR WARS RACER ARCADE DX TYPE.**

This manual is intended for the owners, personnel and managers in charge of operation of the product. Operate the product after carefully reading and sufficiently understanding the instructions. If the product fails to function satisfactorily, non-technical personnel should under no circumstances touch the internal system. Please contact where the product was purchased from.

Use of this product is unlikely to cause physical injuries or damages to property. However, where special attention is required this is indicated by a thick line, the word "IMPORTANT" and its sign in this manual.



**IMPORTANT**

Indicates that mishandling the product by disregarding this display can cause the product's intrinsic performance not to be obtained, resulting in malfunctioning.

SEGA ENTERPRISES, INC. (U.S.A.)/CUSTOMER SERVICE  
45133 Industrial Drive, Fremont, California 94538, U.S.A.  
Phone : (415) 701-6580  
Fax : (415) 701-6594

## DEFINITION OF LOCATION MAINTENANCE MAN AND SERVICEMAN



Non-technical personnel who do not have technical knowledge and expertise should refrain from performing such work that this manual requires the location's maintenance man or a serviceman to carry out, or work which is not explained in this manual. Failing to comply with this instruction can cause a severe accident such as electric shock.

Ensure that parts replacement, servicing & inspections, and troubleshooting are performed by the location's maintenance man or the serviceman. It is instructed herein that particularly hazardous work should be performed by the serviceman who has technical expertise and knowledge.

The location's maintenance man and serviceman are herein defined as follows:

### **"Location's Maintenance Man" :**

Those who have experience in the maintenance of amusement equipment and vending machines, etc., and also participate in the servicing and control of the equipment through such routine work as equipment assembly and installation, servicing and inspections, replacement of units and consumables, etc. within the Amusement Facilities and or locations under the management of the Owner and Owner's Operators of the product.

### **Activities of Location's Maintenance Man :**

Assembly & installation, servicing & inspections, and replacement of units & consumables as regards amusement equipment, vending machines, etc.

### **Serviceman :**

Those who participate in the designing, manufacturing, inspections and maintenance service of the equipment at an amusement equipment manufacturer.

Those who have technical expertise equivalent to that of technical high school graduates as regards electricity, electronics and or mechanical engineering, and daily take part in the servicing & control and repair of amusement equipment.

### **Serviceman's Activities :**

Assembly & installation and repair & adjustments of electrical, electronic and mechanical parts of amusement equipment and vending machines.

**LISTED**



**5K92**

**AMUSEMENT MACHINE**

# 1. HANDLING PRECAUTIONS

When installing or inspecting the machine, be very careful of the following points and pay attention to ensure that the player can enjoy the game safely.

Non-compliance with the following points or inappropriate handling running counter to the cautionary matters herein stated can cause personal injury or damage to the machine.



WARNING!

- Before performing work, be sure to turn power off. Performing the work without turning power off can cause an electric shock or short circuit. In the case work should be performed in the status of power on, this manual always states to that effect.
- To avoid electric shock or short circuit, do not plug in or unplug quickly.
- To avoid electric shock, do not plug in or unplug with a wet hand.
- Do not expose Power Cords and Earth Wires on the surface, (floor, passage, etc.). If exposed, the Power Cords and Earth Wires are susceptible to damage. Damaged cords and wires can cause electric shock or short circuit.
- To avoid causing a fire or electric shock, do not put things on or damage Power Cords.
- When or after installing the product, do not unnecessarily pull the power cord. If damaged, the power cord can cause a fire or electric shock.
- In case the power cord is damaged, ask for replacement through where the product was purchased from or the office herein stated. Using the cord as is damaged can cause fire, electric shock or leakage.
- Be sure to perform grounding appropriately. Inappropriate grounding can cause an electric shock.
- Be sure to use fuses meeting specified rating. Using fuses exceeding the specified rating can cause a fire or electric shock.
- Completely make connector connections for IC BD and others. Insufficient insertion can cause an electric shock.
- Specification changes, removal of equipment, conversion and/or addition, not designated by SEGA are not permitted.
  - Failure to observe this may cause a fire or an electric shock. Non-compliance with this instruction can have a bad influence upon physical conditions of the players or the lookers-on, or result in injury during play.
  - SEGA shall not be held responsible for damage, compensation for damage to a third party, caused by specification changes not designated by SEGA.
- Be sure to perform periodic maintenance inspections herein stated.



IMPORTANT

- For the IC board circuit inspections, only the logic tester is allowed. The use of a multiple-purpose tester is not permitted, so be careful in this regard.
- The Projector is employed for this machine. The Projector's screen is susceptible to damage, therefore, be very careful when cleaning the screen. For details, refer to PROJECTOR.



## 2. PRECAUTIONS CONCERNING INSTALLATION

### LOCATION



This product is an indoor game machine. Do not install it outside. Even indoors, avoid installing in places mentioned below so as not to cause a fire, electric shock, injury and or malfunctioning.

- Places subject to rain or water leakage, or places subject to high humidity in the proximity of an indoor swimming pool and or shower, etc.
- Places subject to direct sunlight, or places subject to high temperatures in the proximity of heating units, etc.
- Places filled with inflammable gas or vicinity of highly inflammable/volatile chemicals or hazardous matter.
- Dusty places.
- Sloped surfaces.
- Places subject to any type of violent impact.
- Vicinity of anti-disaster facilities such as fire exits and fire extinguishers.
- The operating (ambient) temperature range is from 5 C° to 40 C°. Only in the case a projector is employed, the temperature range is from 5 C° to 30 C°.

### LIMITATIONS OF USAGE REQUIREMENTS



- Be sure to check the Electrical Specifications. Ensure that this product is compatible with the location's power supply, voltage and frequency requirements. A plate describing Electrical Specifications is attached to the product. Non-compliance with the Electrical Specifications can cause a fire and electric shock.
- This product requires the Breaker and Earth Mechanisms as part of the location facilities. Using them in a manner not independent can cause a fire and electric shock.
- Ensure that the indoor wiring for the power supply is rated at 15A or higher (AC single phase 100 ~ 120V area), and 7A or higher (AC 220 ~ 240V area). Non-compliance with the Electrical Specifications can cause a fire and electric shock.
- Be sure to independently use the power supply equipped with the Earth Leakage Breaker. Using a power supply without the Earth Leakage Breaker can cause an outbreak of fire when earth leakage occurs.
- Putting many loads on one electrical outlet can cause generation of heat and a fire resulting from overload.
- When using an extension cord, ensure that the cord is rated at 15A or higher (AC 100 ~ 120V area) and 7A or higher (AC 220 ~ 240V area). Using a cord rated lower than the specified rating can cause a fire and electric shock.

OPERATION AREA



- For the operation of this machine, secure a minimum area of 1.8m (W) X 2.93m (D). In order to prevent injury resulting from the falling down accident during game play, be sure to secure the minimum area for operation.
- Be sure to provide sufficient space so as to allow this product's ventilation fan to function efficiently. To avoid machine malfunctioning and a fire, do not place any obstacles near the ventilation opening.
- SEGA shall not be held responsible for damage, compensation for damage to a third party, resulting from the failure to observe this instruction.



For transporting the machine into the location's building, the minimum necessary dimensions of the opening (of doors, etc.) are 1m(W) and 1.7m(H).

Electric current consumption

- MAX. 6.7 A (AC 110V 50 Hz)
- MAX. 6.7 A (AC 110V 60 Hz)
- MAX. 6.0 A (AC 120V 60 Hz)
- MAX. 3.5 A (AC 220V 50 Hz)
- MAX. 3.4 A (AC 220V 60 Hz)
- MAX. 3.4 A (AC 230V 50 Hz)
- MAX. 3.2 A (AC 230V 60 Hz)
- MAX. 3.2 A (AC 240V 50 Hz)
- MAX. 3.2 A (AC 240V 60 Hz)
- MAX. 6.7 A (For TAIWAN)

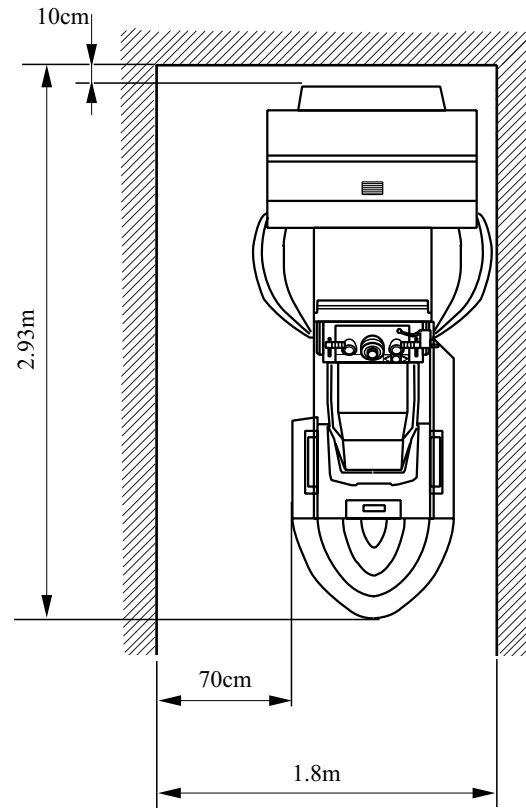

FIG. 2

### 3. OPERATION

#### PRECAUTIONS TO BE HEEDED BEFORE STARTING THE OPERATION

To avoid injury and trouble, be sure to constantly give careful attention to the behavior and manner of the visitors and players.



In order to avoid accidents, check the following before starting the operation:

- To ensure maximum safety for the players and the customers, ensure that where the product is operated has sufficient lighting to allow any warnings to be read. Operation under insufficient lighting can cause bodily contact with each other, hitting accident, and or trouble between customers.
- Be sure to perform appropriate adjustment of the monitor (projector). For operation of this machine, do not leave monitor's flickering or deviation as is. Failure to observe this can have a bad influence upon the players' or the customers' physical conditions.
- It is suggested to ensure a space allowing the players who feel sick while playing the game to take a rest.
- Check if all of the adjusters are in contact with the surface. If they are not, the Cabinet can move and cause an accident.

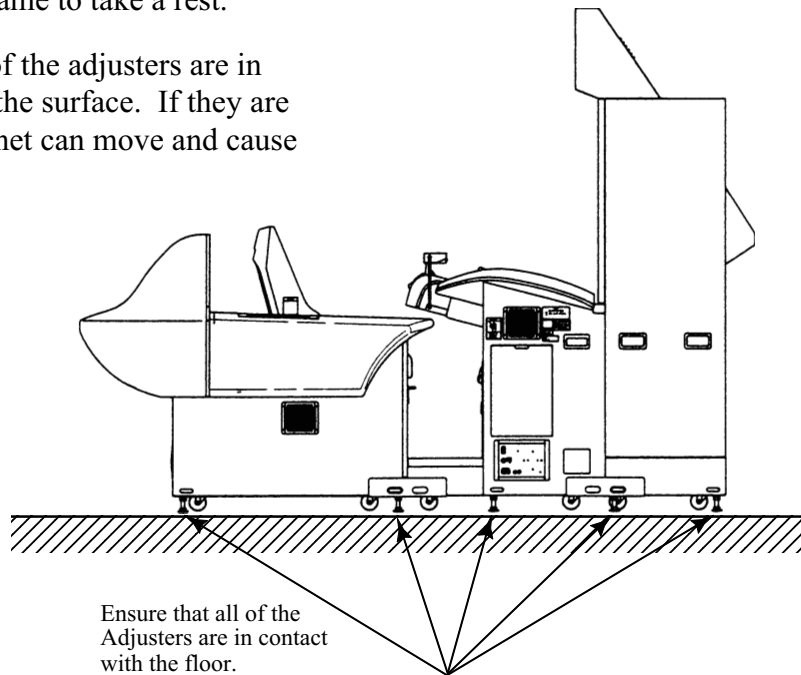

- Do not put any heavy item on this product. Placing any heavy item on the product can cause a falling down accident or parts damage.
- Do not climb on the product. Climbing on the product can cause falling down accidents. To check the top portion of the product, use a step.
- To avoid electric shock, check to see if door & cover parts are damaged or omitted.
- To avoid electric shock, short circuit and or parts damage, do not put the following items on or in the periphery of the product.  
Flower vases, flowerpots, cups, water tanks, cosmetics, and receptacles/containers/vessels containing chemicals and water.



CAUTION!

To avoid injury, be sure to provide sufficient space by considering the potentially crowded situation at the installation location. Insufficient installation space can cause making bodily contact with each other, hitting accidents, and or trouble between customers.

PRECAUTIONS TO BE HEEDED DURING OPERATION (PAYING ATTENTION TO CUSTOMERS)

To avoid injury and trouble, be sure to constantly give careful attention to the behavior and manner of the visitors and players.



WARNING!

- To avoid injury and accidents, those who fall under the following categories are not allowed to play the game.
  - Those who need assistance such as the use of an apparatus when walking.
  - Those who have high blood pressure or a heart problem.
  - Those who have experienced muscle convulsion or loss of consciousness when playing video game, etc.
  - Those who have a trouble in the neck and or spinal cord.
  - Pregnant women or those who are in the likelihood of pregnancy.
  - Persons susceptible to motion sickness.
  - Persons whose act runs counter to the product's warning displays.
- A player who has never been adversely affected by light stimulus might experience dizziness or headache depending on his physical condition when playing the game. Especially, small children can be subject to those conditions. Caution guardians of small children to keep watch on their children during play.
- Instruct those who feel sick during play to have a medical examination.
- To avoid injury resulting from falling down and electric shock due to spilled drinks, instruct the player not to place heavy items or drinks on the product.
- To avoid electric shock and short circuit, do not allow customers to put hands and fingers or extraneous matter in the openings of the product or small openings in or around the doors.
- To avoid falling down and injury resulting from falling down, immediately stop the customer's leaning against or climbing on the product, etc.
- To avoid electric shock and short circuit, do not allow the customers to unplug the power plug without a justifiable reason.
- Check to see that no wastepaper, etc. is left in the space around the rear of the Seat. Such wastepaper left around the seat can cause a fire by discarded cigarette stubs.
- This product is intended for 1 Player only. Playing the game by 2 or more Players riding on the seat together can cause falling down and collision accidents by striking head, hand, or elbow.



- Caution lookers-on so as not to touch the operating unit while in play. Failure to observe this may cause bodily contact with the player and trouble between the customers.

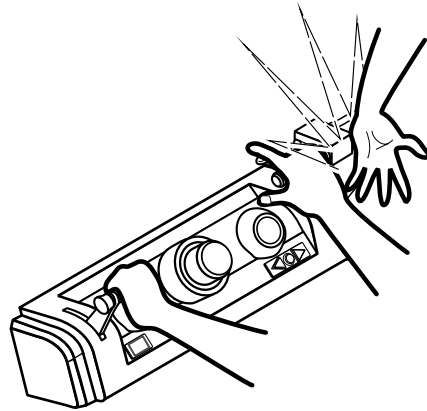

- Caution the player so as not to hold a child in her/his lap to play. Failure to observe this may cause the child to be caught between the Control Panel and the player and fall down.



- Immediately stop such violent acts as hitting and kicking the product. Such violent acts can cause parts damage or falling down, resulting in injury due to fragments and falling down.

- To avoid injuries and accidents, do not allow the customers to put hands, arms, or head in the opening space between the seat and the cabinet.

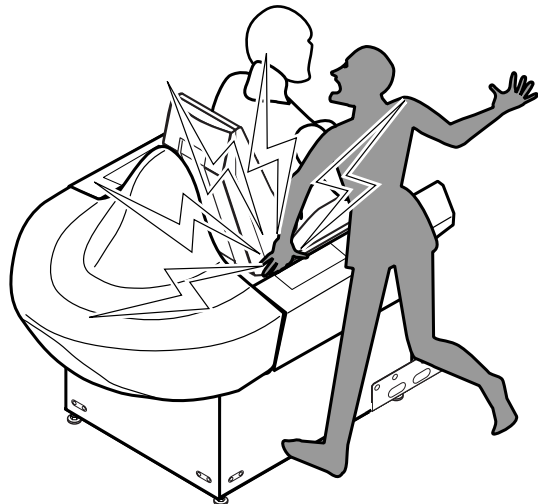

- Instruct the Player to adjust the seat before playing the game. Playing the game in a forcible posture can cause a contingent accident.

## 4. NAME OF PARTS

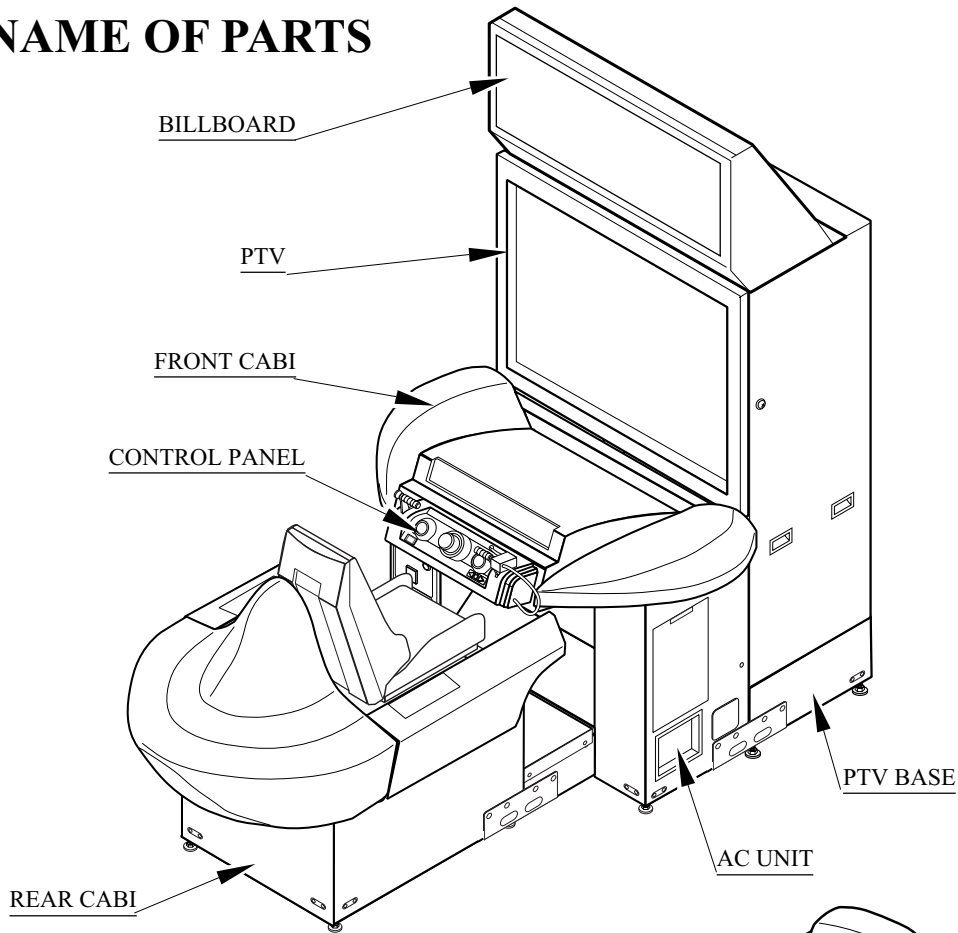

FIG. 4 a OVERVIEW

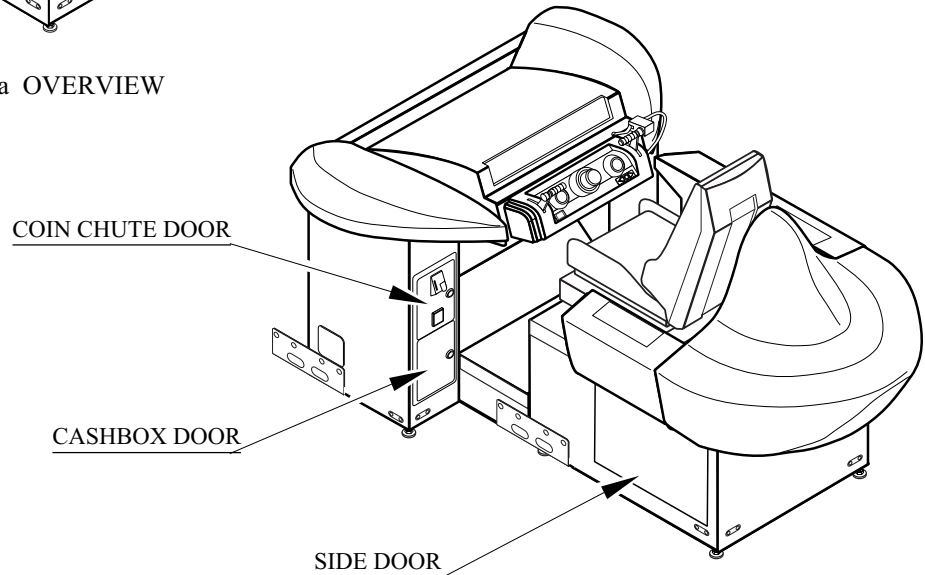

FIG. 4 b

TABLE 4

	Width	X	Length	X	Height	Weight
PTV	1,140 mm	X	555 mm	X	1,670 mm	112 kg
PTV BASE	1,160 mm	X	545 mm	X	235 mm	19 kg
FRONT CABI	1,310 mm	X	880 mm	X	1,130 mm	100 kg
REAR CABI	890 mm	X	1,650 mm	X	1,260 mm	120 kg
BILLBOARD	1,140 mm	X	400 mm	X	410 mm	19 kg
When assembled	1,310 mm	X	2,830 mm	X	2,230 mm	370 kg

When the POP is attached, the height is 2,660mm.

# 5. ACCESSORIES

When transporting the machine, make sure that the following parts are supplied.

TABLE 5 ACCESSORIES

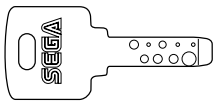
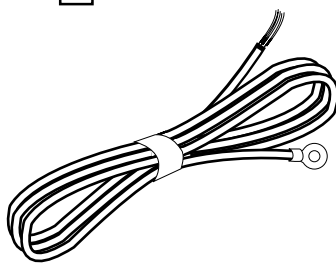
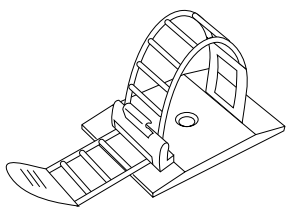
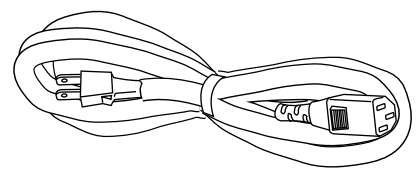
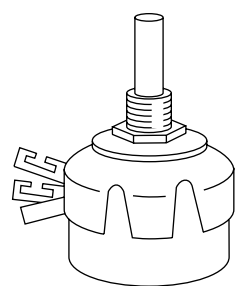
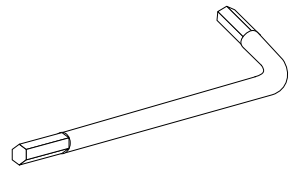
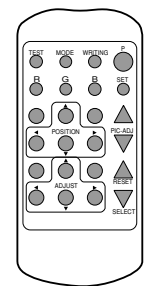
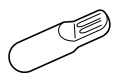
<p><b>DESCRIPTION</b></p> <p>Part No. (Qty.)</p> <p>Note</p> <p>Figures</p> <p>If Part No. has no description, the Number has not been registered or can not be registered. Such a part may not be obtainable even if the customer desires to purchase it. Therefore, ensure that the part is in safekeeping with you.</p>	<p><b>OWNERS MANUAL</b></p> <p>420-6575-01 (1)</p>	<p><b>KEY MASTER</b></p> <p>220-5576 (2)</p> <p>For opening/closing the doors</p>	<p><b>KEY (2)</b></p> <p>For the CASHBOX DOOR</p>
<p>AC Cable (Power Cord)</p> <p>600-6228</p> <p>600-6729 (1) TAIWAN</p> <p>600-6618 (1) OTHERS</p> <p>600-6619 (1) HONG KONG</p> <p>600-6695 (1) USA</p>	<p><b>WIRE HARN EARTH W/LUG M6</b></p> <p>600-6664-02 (1)</p> <p>For TAIWAN.</p> <p>Used for installation, see <b>4</b> of Section 6.</p>	<p><b>CORD CLAMP</b></p> <p>280-5009-01 (1)</p> <p>Used for securing the power cord. see <b>4</b> of Section 6.</p>	
<p>Used for installation, see <b>4</b> of Section 6.</p>			<p>The Keys are inside the Coin Chute Door at the time of shipment from the factory.</p>
	<p><b>TAMPERPROOF†WRENCH M8</b></p> <p>540-0009-01 (1)</p> <p>TOOL</p>	<p><b>TOSHIBA</b></p> <p>Remote Controller used for adjustment of the projector. See Section 12.</p> <p>200-5536(1)</p>	<p><b>VOL CONT B-5K OHM</b></p> <p>220-5373</p> <p>220-5484<sup>(1)</sup></p> <p>Spare, see Section 10.</p>
			<p><b>LAMP 6V 3W</b></p> <p>390-5160 (1)</p> <p>Spare, refer to Section 13.</p>
	<p>The Remote Controller is attached to the Projector at the time of shipment.</p>		

STATICIDE (300ML)  
090-0074 (1)  
Articles of consumption  
(see below).

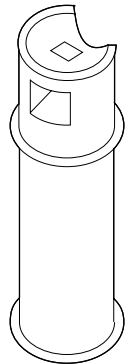

Periodically once every two months as standard, apply the "STATICIDE" (an antistatic spray agent) to the SEATs and wipe with a dry cloth.

OPT CONN BRKT  
POD-0004 (2)

For communication play,  
refer to Section 18.

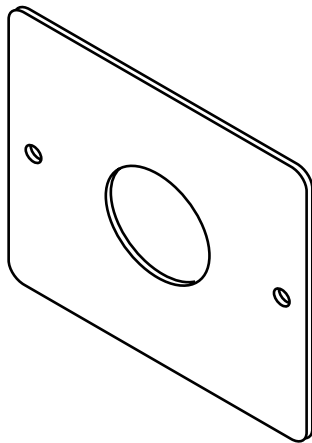

FLEX TUBE  
310-5285-290100 (1)

For communication play,  
refer to Section 18.

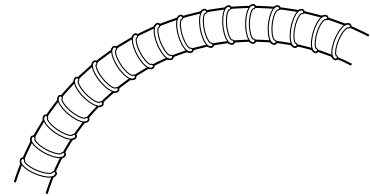

ASSY FIBER CABLE  
600-6275-0700 (2)

For communication play,  
refer to Section 18.

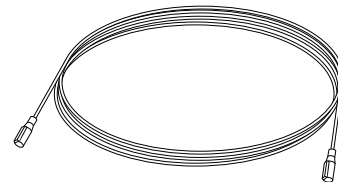

CONN 29  
310-5286-29 (2)

For communication play,  
refer to Section 18.

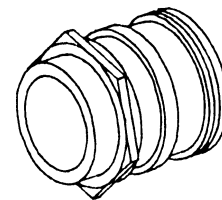

CARTON BOX  
601-10642 (1)

Used for transporting the  
Game Board.  
Refer to Next Page.

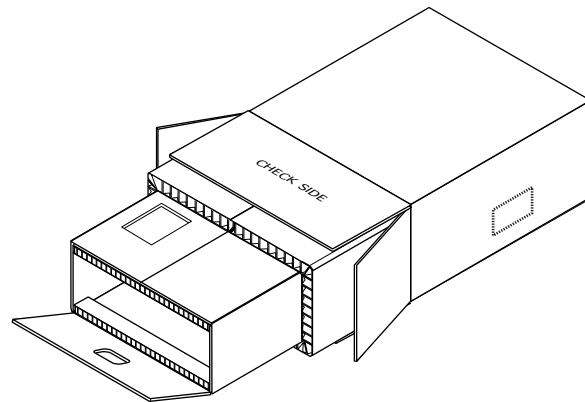



## HOW TO USE THE CARTON BOX



- When asking for the replacement or repair of the product's Game Board (SEGA HIKARU), be sure to put the Game Board together with the Shield Case in a Carton Box. Otherwise, the request is not acceptable.
- Put the Shield Case in the Carton Box by paying attention to the correct direction as per the following instructions and as shown by the instructions printed on the Carton Box. Handling in an erroneous manner can damage the Game Board.
- Remove the Shield Case Brackets from the Shield Case and put the Shield Case in the Carton Box.

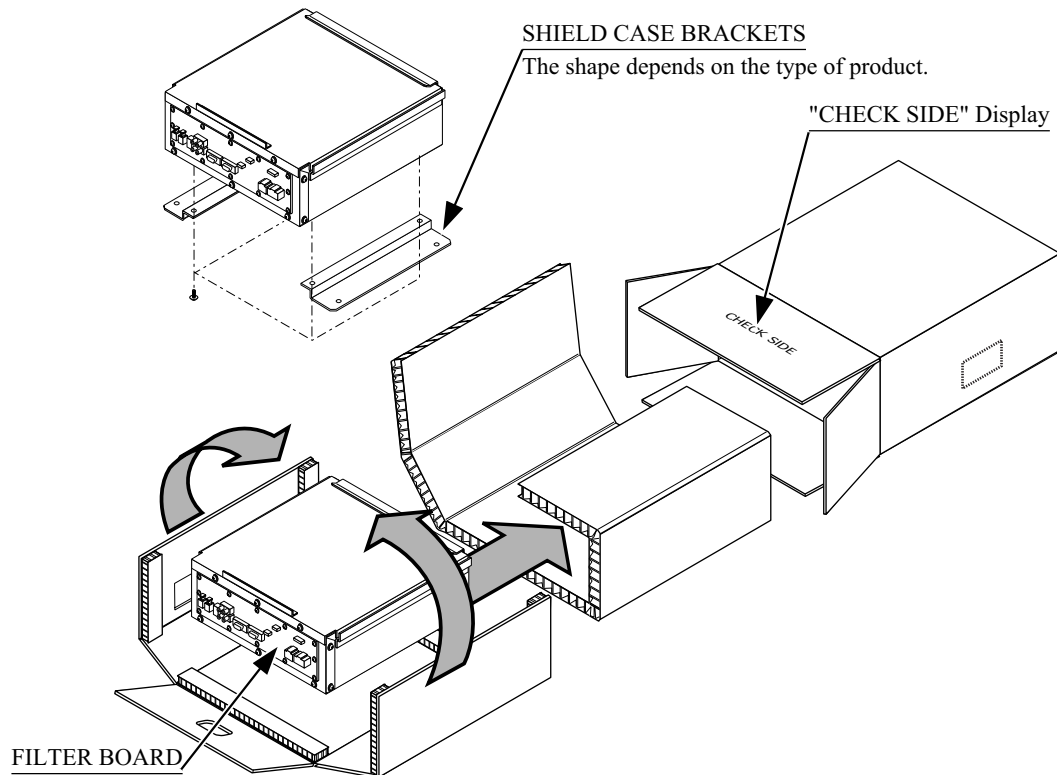

Wrap the Shield Case with the packing material and put it in the Carton Box as shown. Putting it upside down or packing otherwise in the manner not shown can damage the Game Board and parts.

## 6. ASSEMBLING AND INSTALLATION



WARNING!

- Perform assembly work by following the procedure herein stated. Failing to comply with the instructions can cause electric shock hazard.
- Perform assembling as per this manual. Since this is a complex machine, erroneous assembling can cause an electric shock, machine damage and or not functioning as per specified performance.
- When assembling, be sure to use plural persons. Depending on the assembly work, there are some cases in which working by one person alone can cause personal injury or parts damage.
- Ensure that connectors are accurately connected. Incomplete connections can cause electric shock hazard.
- Be careful so as not to damage wirings. Damaged wiring can cause electric shock and short circuit hazards.
- Do not carelessly push the PTV. Pushing the PTV carelessly can cause the PTV to fall down.
- This work should be performed by the Location's Maintenance Man or Serviceman. Performing work by non-technical personnel can cause a severe accident such as electric shock. Failing to comply with this instruction can cause a severe accident such as electric shock to the player during operation.
- Provide sufficient space so that assembling can be performed. Performing work in places with narrow space or low ceiling may cause an accident and assembly work to be difficult.
- To perform work safely and avoid serious accident such as the cabinet's falling down, do not perform work in places where step-like grade differences, a ditch, or slope exist.



CAUTION!

- When handling plastic parts, use care. Do not give a shock or apply excessive load to the fluorescent lamps and plastic parts. Failure to observe this can cause parts damage, resulting in injury due to fragments, cracks and broken pieces.
- To perform work safely and securely, be sure to prepare a step which is in a secure and stable condition. Performing work without using the step can cause violent falling down accidents.

When carrying out the assembling and installation, follow the following 6-item sequence.

- 1 ASSEMBLING THE PTV
- 2 ASSEMBLING THE CABINET
- 3 SECURING IN PLACE (ADJUSTER ADJUSTMENT)
- 4 POWER SUPPLY CONNECTION
- 5 TURNING POWER ON
- 6 ASSEMBLING CHECK

The master key (accessories) in addition to the tools such as a Phillips type screwdriver, wrench, socket wrench and Ratchet Handle are required for the assembly work.

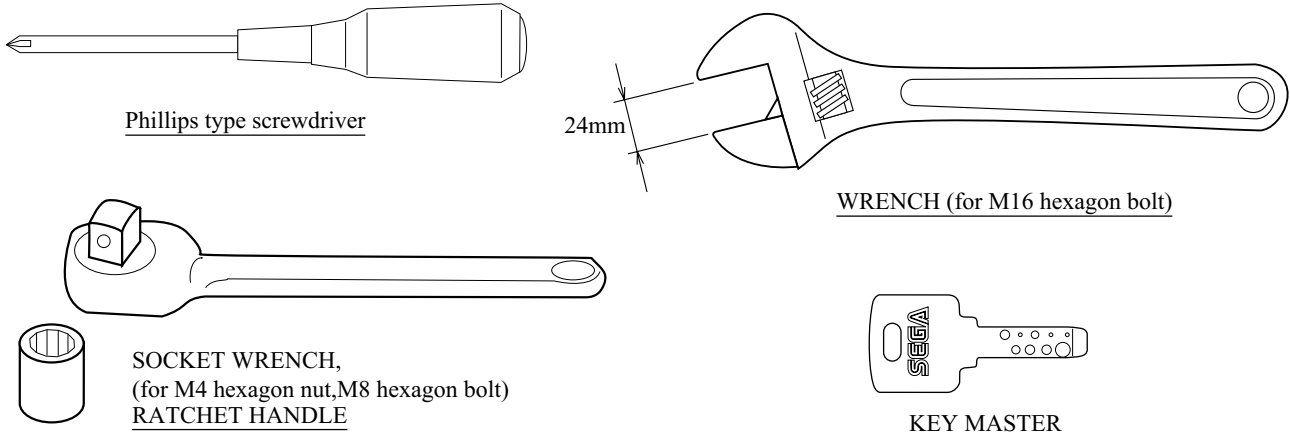

**1**

### ASSEMBLING THE PTV

- ① By using the 2 specified screws, secure the 2 Mask Holders to the PTV ceiling.
- ② Insert the TV Mask from the bottom as shown and secure with the 6 screws.
- ③ By using the 2 screws for each, secure the 2 PTV Holders to the PTV front.

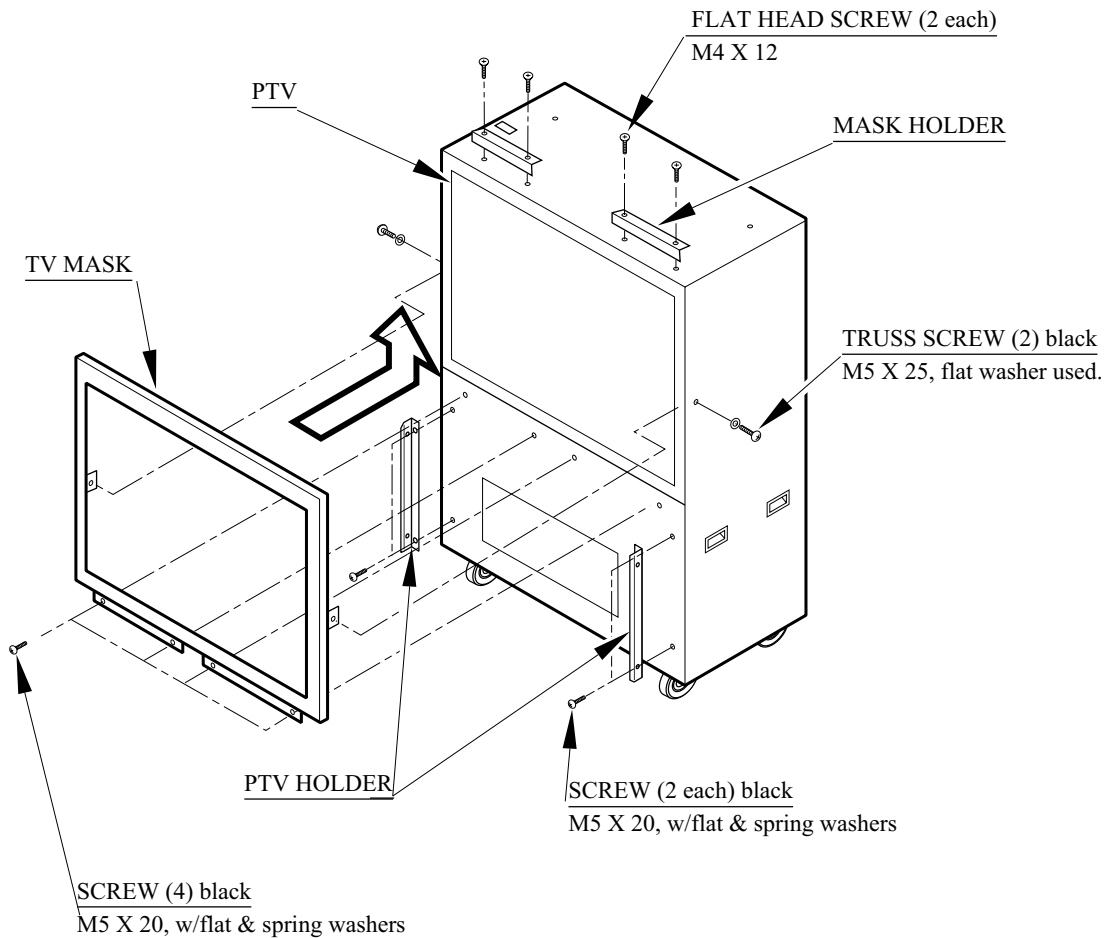

FIG. 6. 1

2

ASSEMBLING THE CABINET

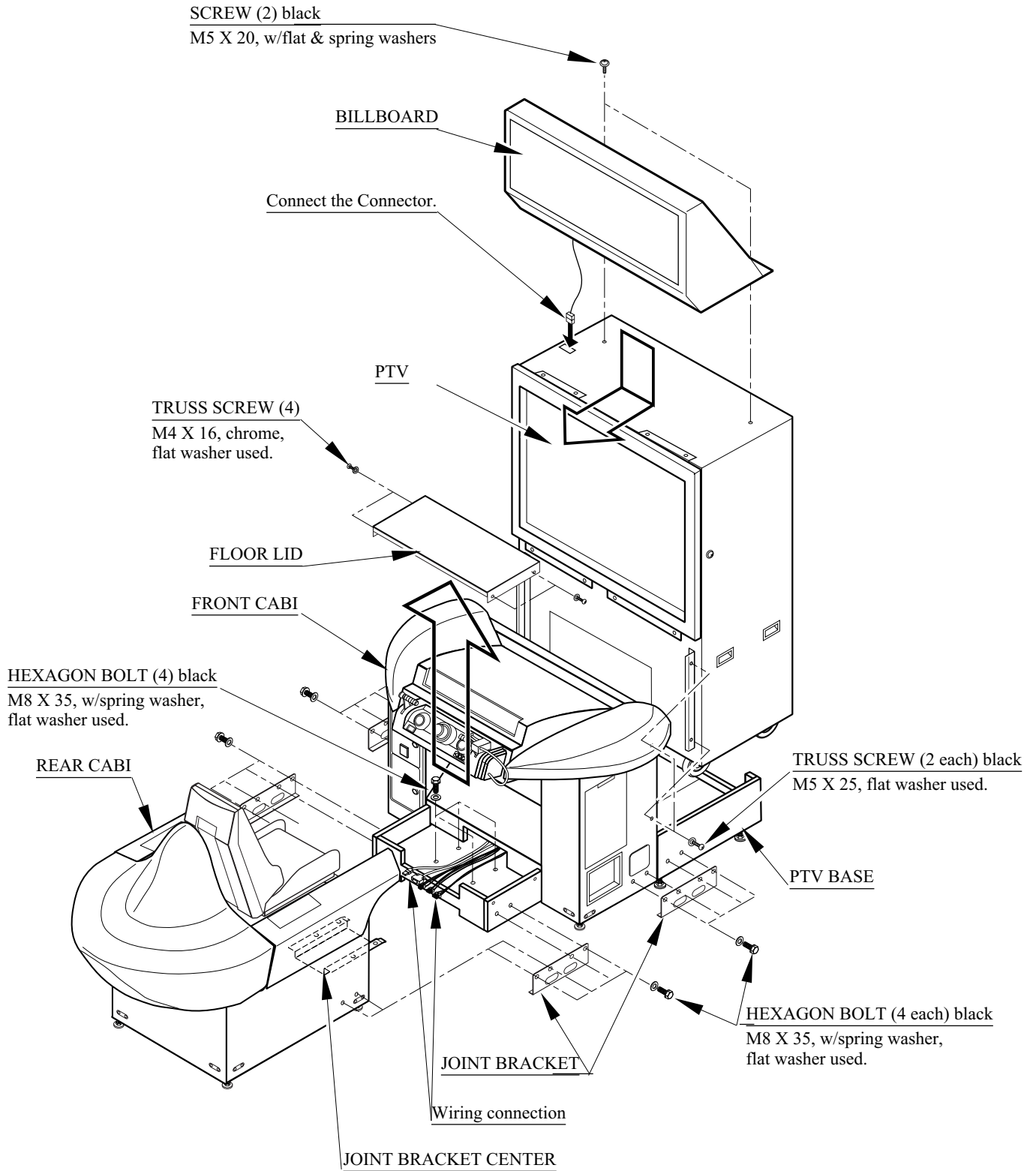
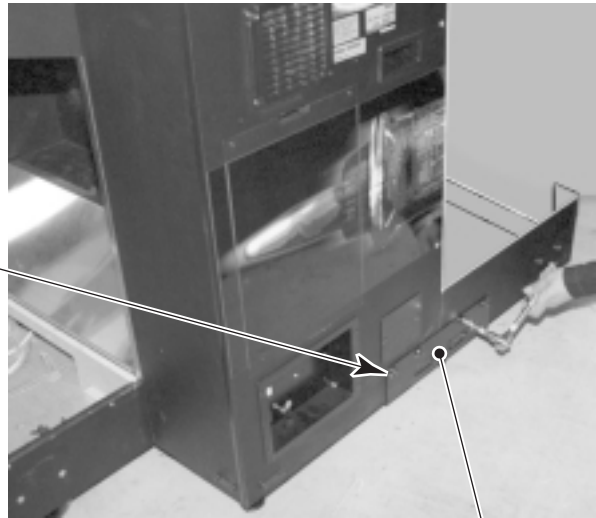

FIG. 6. 2 a

- ① Join the FRONT CABI and the PTV Base and secure by installing the Joint Brackets to the cabinet left and right. Secure the Joint Brackets with the 4 Hexagon bolts for each.

HEXAGON BOLT (4 each) black  
M8 X 35, w/spring washer,  
flat washer used.



JOINT BRACKET

PHOTO 6. 2 a

- ② Mount the PTV on the PTV Base. The PTV weighs approximately 100kg. Be sure to lift the PTV by 4 or more workers while another worker supporting the PTV Base and the FRONT CABI.

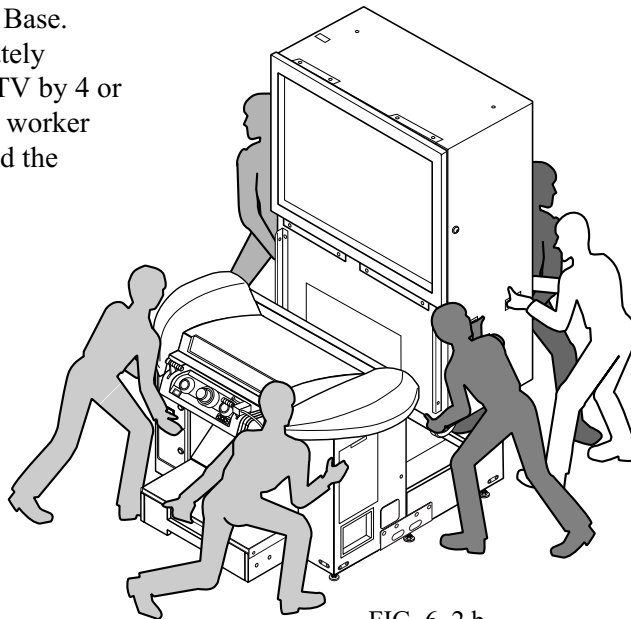
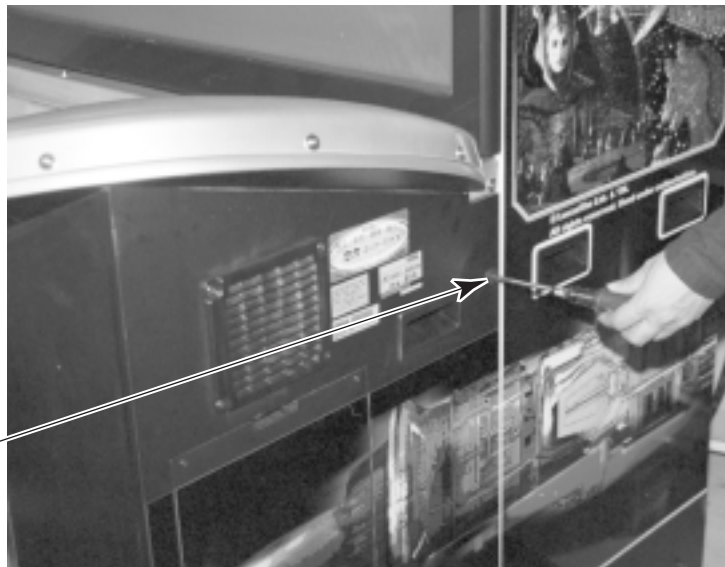

FIG. 6. 2 b

- ③ Fasten the 2 Truss screws to the FRONT CABI left & right and secure the PTV and the FRONT CABI.

TRUSS SCREW (2 each) black  
M5 X 25, flat washer used.



- ④ Connect a Billboard's connector to the terminal board on the PTV ceiling. While supporting the Billboard as is inclined, connect the connector. Be sure to use a step to connect the connector while 2 persons supporting the Billboard.
- ⑤ Insert the Billboard from the rear as shown and secure with the 2 screws. At this time, be sure to use a step.

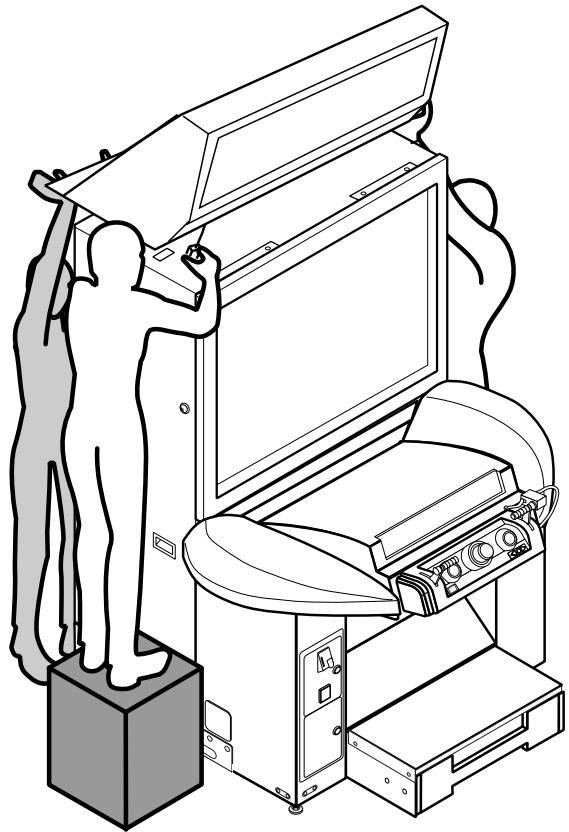
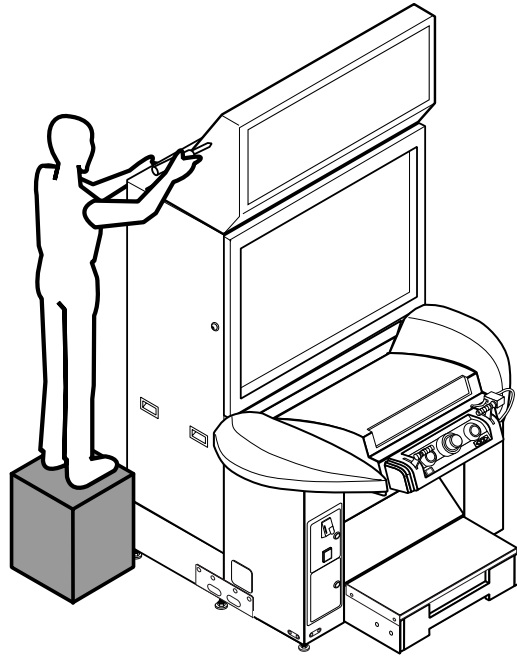

For performing work, prepare a step and use 3 or more workers.

FIG 6. 2 c

When performing work, be sure to use a step.

- ⑥ Take out the 2 screws which secure the Front Lid on the FRONT CABI and bring down the Front Lid toward you. Inside the Front Lid wiring is secured. Use care so as not to damage wiring.

TRUSS SCREW (2) black  
M4 X 30, flat washer used.

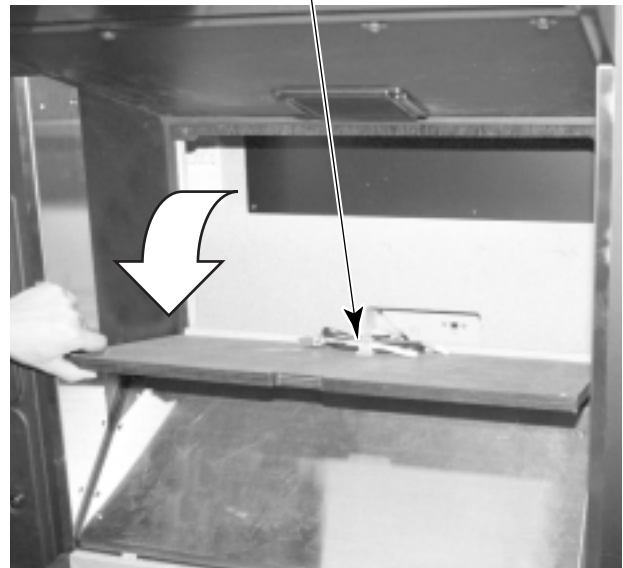

FRONT LID

PHOTO 6. 2 c

- ⑦ Perform wiring connection between the PTV and the FRONT CABI. Connect the connectors from the FRONT CABI for the main supply and for the reflection signal to each of the 2 connectors of the connector panel on the PTV front. The inserting angle for each connector is predetermined. To avoid damaging the connector, be sure to check the correct direction for inserting the connector. The reflection signal connector has the securing screws at the both ends. After connecting, fasten the screws tightly.

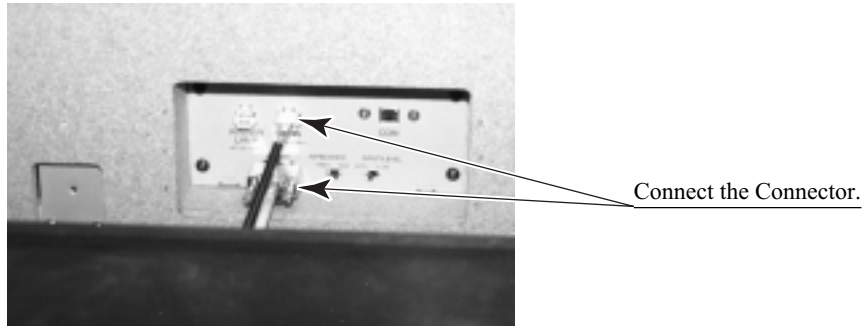

PHOTO 6. 2 d

- ⑧ Close the Front Lid and secure with the 2 Truss screws.
- ⑨ Take off the 4 Truss screws which secure the Floor Lid on the FRONT CABI and remove the Floor Lid.

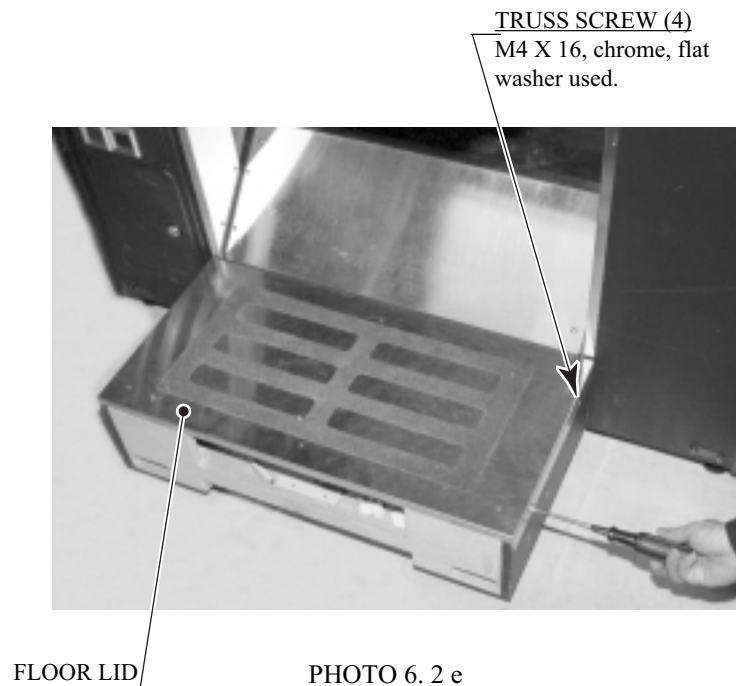

PHOTO 6. 2 e

- ⑩ Join the FRONT CABI and the REAR CABI in the manner as inserting the REAR CABI's Joint Bracket Center underneath the FRONT CABI. At this time, use care so as not to damage wiring.

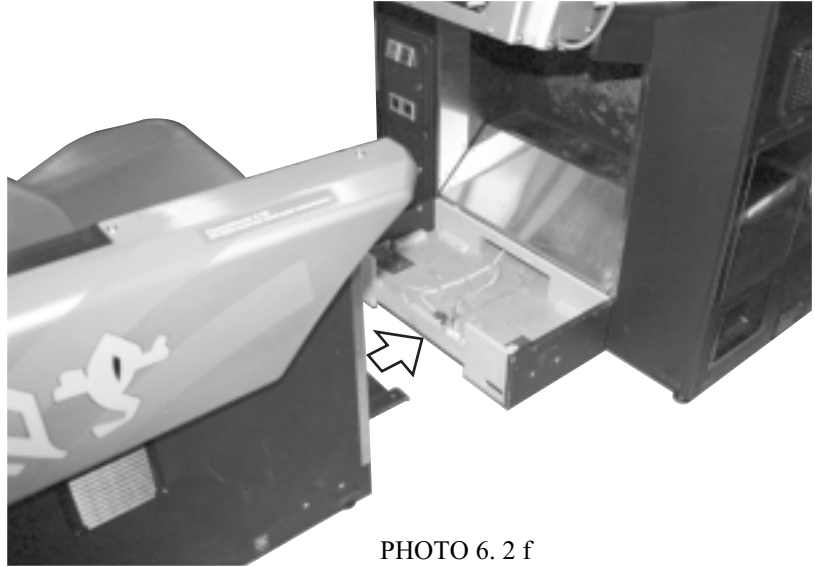

PHOTO 6. 2 f

- ⑪ Fasten the 6 Hexagon bolts inside the Floor Lid to secure the joint portion of the FRONT CABI and the REAR CABI.

HEXAGON BOLT (4) black  
M8 X 35, w/spring washer,  
flat washer used.

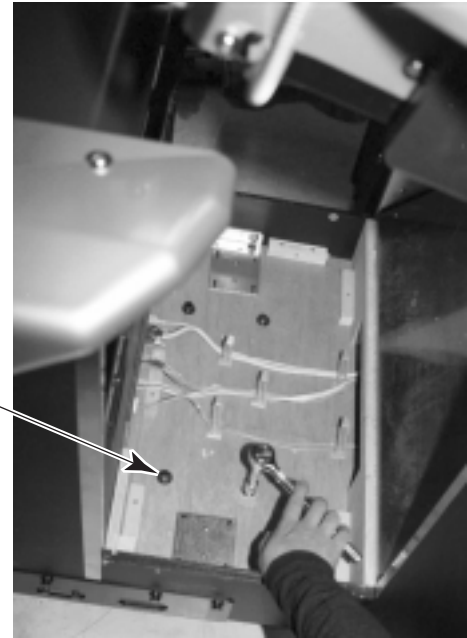
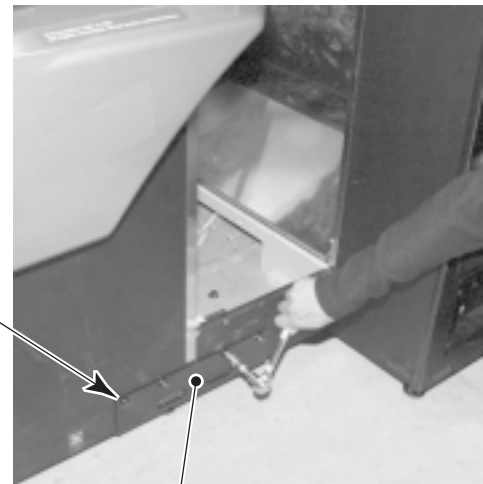

PHOTO 6. 2 g

- ⑫ Secure the FRONT CABI and the REAR CABI by installing the Joint Bracket to the joint portion left and right. Secure the Joint Bracket with the 4 Hexagon bolts for each.

JOINT BRACKET

PHOTO 6. 2 h



HEXAGON BOLT (4 each) black  
M8 X 35, w/spring washer,flat washer used.



- ⑬ Perform wiring connection between the FRONT CABI and the REAR CABI. Connect the wiring connector inside the FRONT CABI to the connector on the connector panel of the REAR CABI. The inserting angle for each connector is predetermined. To avoid damaging the connector, be sure to check the correct direction for inserting the connector. The reflection signal connector has the securing screws at the both ends. After connecting, fasten the screws tightly.

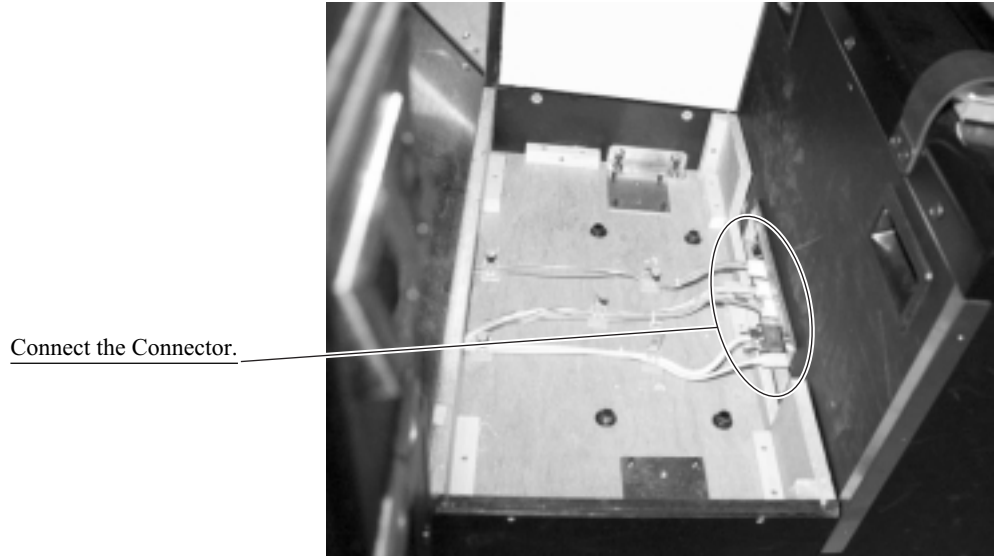

PHOTO 6. 2 i

- ⑭ Install the Floor Lid and secure with the 4 Truss screws.

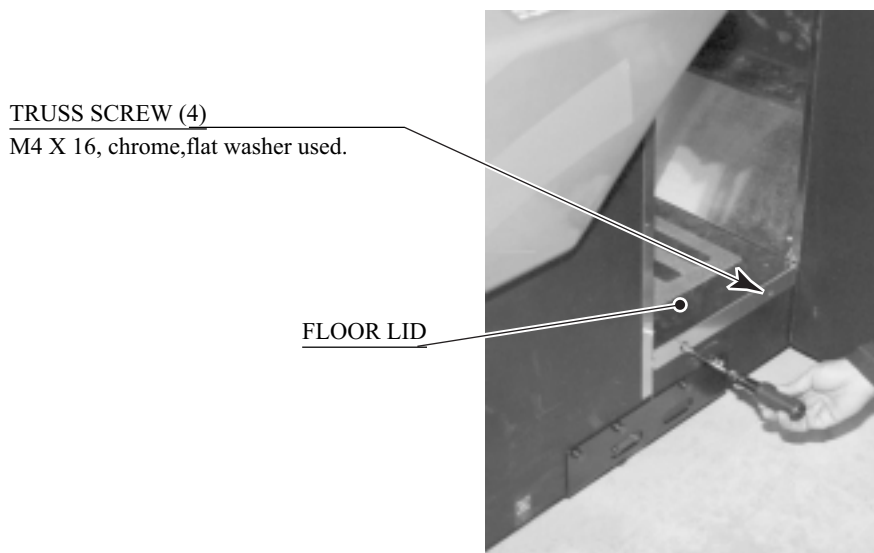

PHOTO 6. 2 j

## INSTALLING THE POP

- ① Peel off the double-sided adhesive tape on the POP reverse and stick the POP Holder.
- ② By using the 3 Truss screws, secure the POP Holder to the Billboard ceiling.

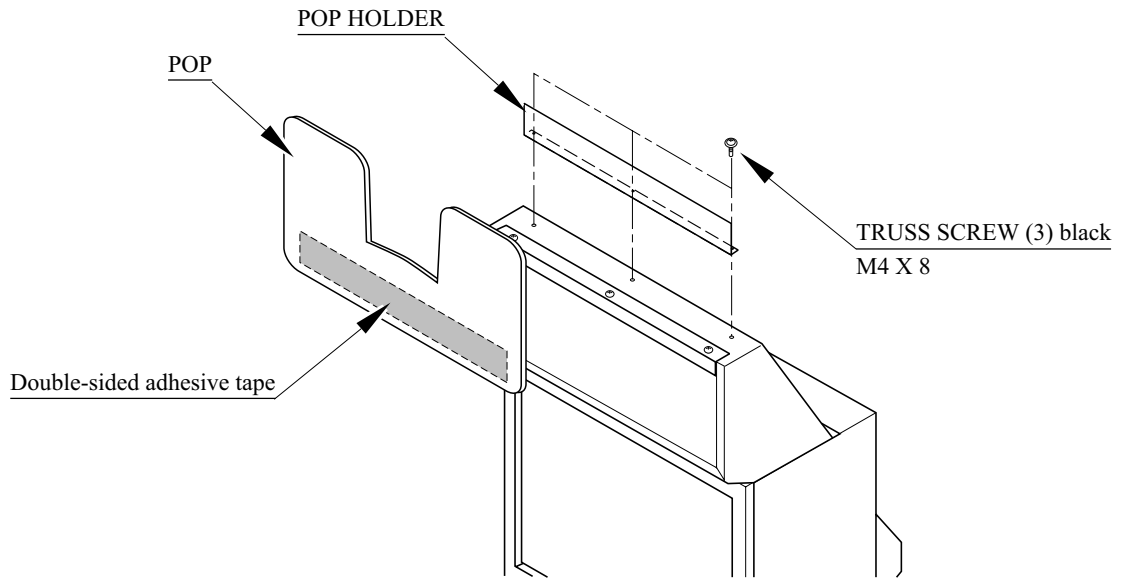

FIG 6. 2 d

# 3

## SECURING IN PLACE (ADJUSTER ADJUSTMENT)



Make sure that all of the adjusters are in contact with the floor. If they are not, the cabinet can move and cause an accident.

This product has 12 casters (4 for PTV base, 4 for Front Cabi, 4 for Rear Cabi) and 10 Adjusters (4 for PTV base, 2 for Front Cabi, 4 for Rear Cabi). (FIG. 6. 3a) When the installation position is determined, cause the adjusters to come into contact with the floor directly, make adjustments in a manner so that the casters will be raised approximately 5mm. from the floor and make sure that the machine position is level.

- ① Transport the product to the installation position. Be sure to provide adequate space allowing the player to get on and off.
- ② Have all of the Adjusters make contact with the floor. Adjust the Adjuster's height by using a wrench so that the machine position is kept level.
- ③ After making adjustment, fasten the Adjuster Nut upward and secure the height of Adjuster (FIG. 6. 3 b).

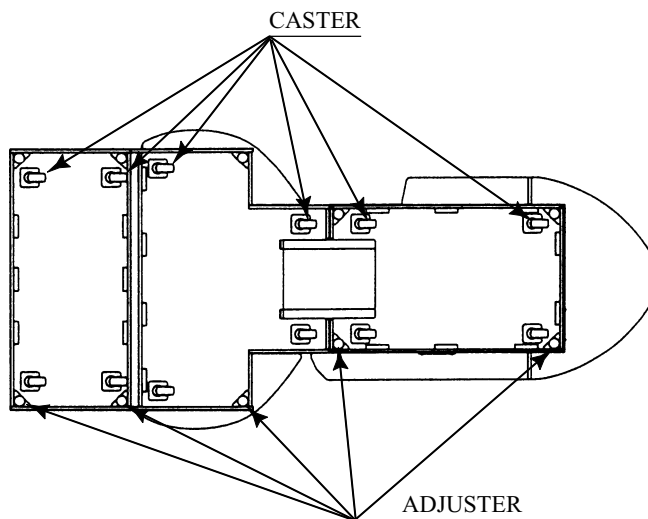

FIG. 6. 3 a BOTTOM VIEW

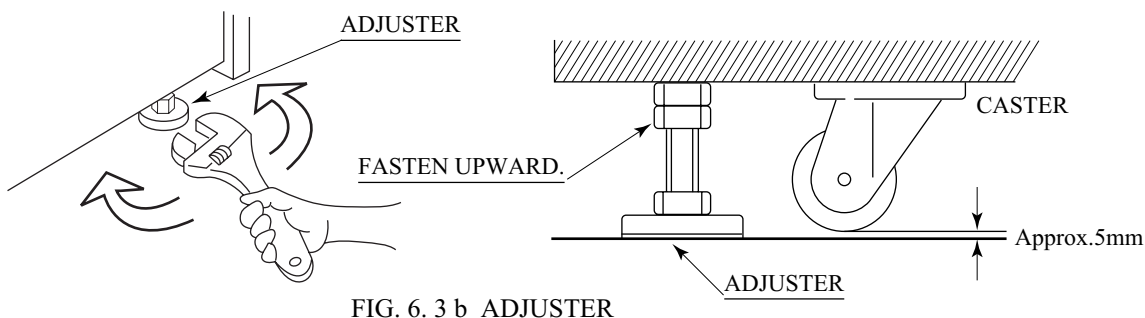

FIG. 6. 3 b ADJUSTER

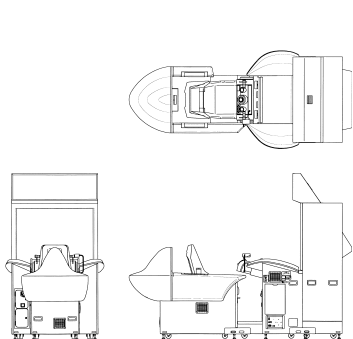

FIG. 6. 3 c

Refer to this Fig. (Scale:1/100) for the layout of the place of installation.

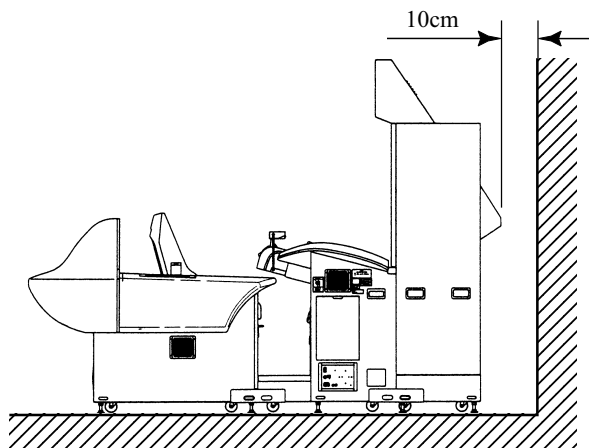

FIG. 6. 3 d

Be sure to provide space as shown between the Air Vent and the wall surface.



## POWER SUPPLY CONNECTION



- Be sure to independently use the power supply socket outlet equipped with an Earth Leakage Breaker. Using a power supply without an Earth Leakage Breaker can cause a fire when electric leakage occurs.
- Ensure that the "accurately grounded indoor earth terminal" and the earth wire cable are available (except in the case where a power cord plug with earth is used). This product is equipped with the earth terminal. Connect the earth terminal and the indoor earth terminal with the prepared cable. If the grounding work is not performed appropriately, customers can be subjected to an electric shock, and the product's functioning may not be stable.
- Ensure that the power cord and earth wire are not exposed on the surface (passage, etc.). If exposed, they can be caught and are susceptible to damage. If damaged, the cord and wire can cause electric shock and short circuit accidents. Ensure that the wiring position is not in the customer's passage way or the wiring has protective covering.
- After wiring power cord on the floor, be sure to protect the power cord. Exposed power cord is susceptible to damage and causes an electric shock accident.

The AC Unit is mounted on the right side of the machine. The AC Unit has Main SW, Circuit Protector and the Inlet which connects the Power Cord.

- ① Ensure that the Main SW is OFF.

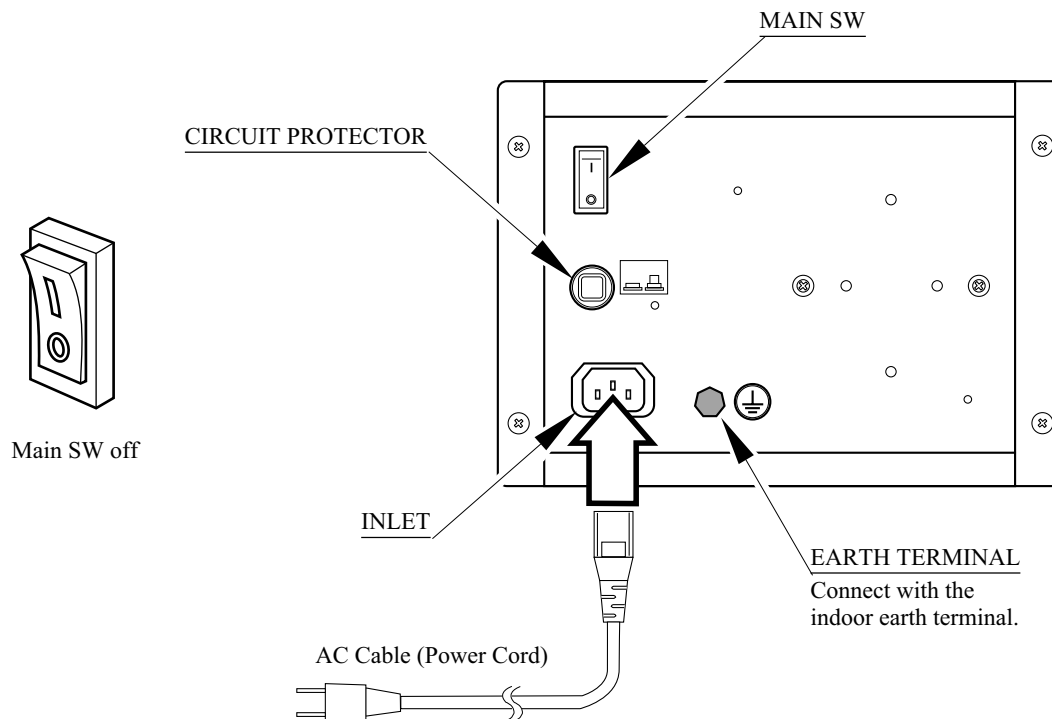
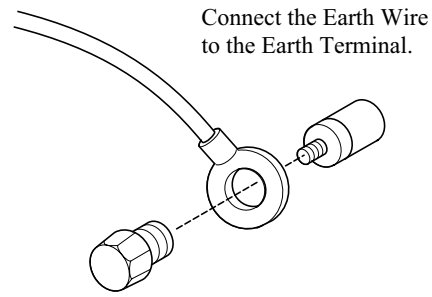

FIG. 6. 4 a AC unit

- ② Connect one end of the earth wire to the AC Unit earth terminal, and the other end to the indoor earth terminal. The AC Unit earth terminal has a Bolt and Nut combination. Take off the Nut, pass the end of earth wire through the Bolt, and fasten the Nut. Note that the Earth Wire is incorporated in the Power Cord for the Areas of AC 120V (USA) and AC 220 ~ 240V, and therefore, this procedure is not necessary.



Connect the Earth Wire to the Earth Terminal.

FIG. 6. 4 b Earth Wire Connection

- ③ Firmly insert the power plug into the socket outlet. Insert the opposite side of Power Cord plug to the AC Unit's connector ("INLET").
- ④ Perform wiring for the Power Cord and Earth Wire. Install protective covering for the Power Cord and Earth Wire.

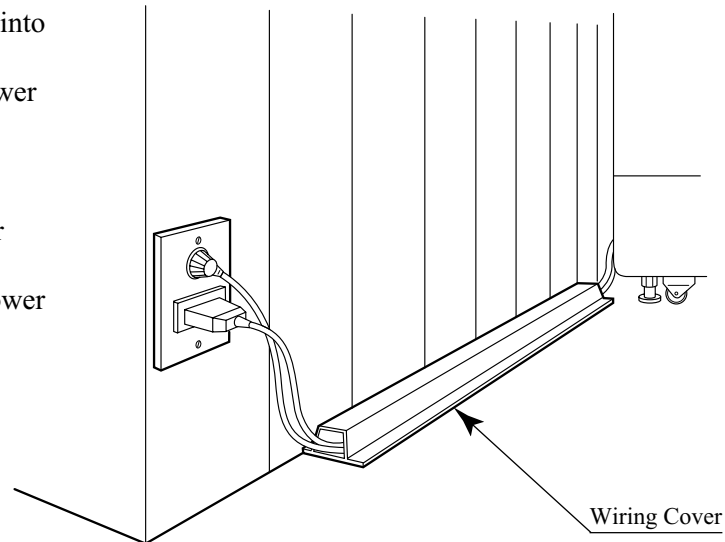

Wiring Cover

FIG. 6. 4 c Connecting Power Cord and Earth Wire

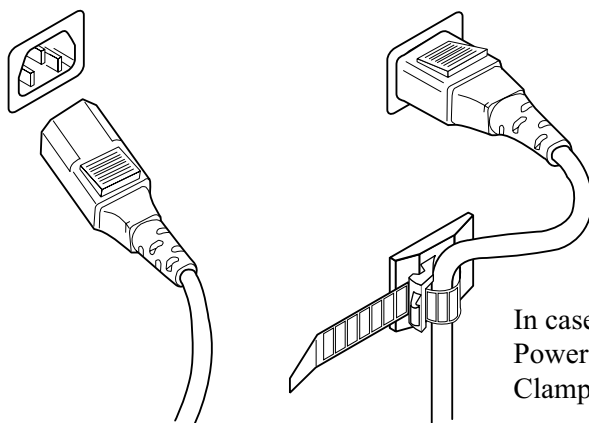

In case the Power Plug is apt to come out of place, secure the Power Cord to the periphery of the AC Unit with the Cord Clamp (an accessory).

#### HOW TO USE THE CORD CLAMP

# 5

## TURNING POWER ON

Turn the AC Unit Main SW on to turn on power. When power is turned on, the fluorescent lamp inside the Billboard lights up. The screen displays the system start-up mode and then proceeds to the ADVERTISE mode. Simultaneously at this time, sound is emitted from the speakers in the front, left and right of the seat. If NO SOUND OUTPUT is set in the TEST mode, sound is not emitted during ADVERTISE. Turning power off does not clear the data such as the number of credits, the ranking, and the latest scores in this product. However, the data of inserted coins less than one credit and BONUS ADDER is cleared once the power is turned off. If power is turned on again after turning it off when the play-worth credits are remaining, the game start screen is displayed on the monitor and the game begins. If the 2 or more machines are linked for communication play, the NETWORK check is performed. The checking screen is displayed before the advertise screen. The advertise screen appears after the checking has been finished. Normally the NETWORK check is finished less than a minute. When there is any problem with communication play, the checking screen is kept displayed. In the case of error, an error message is displayed for a while and the NETWORK check is performed again.

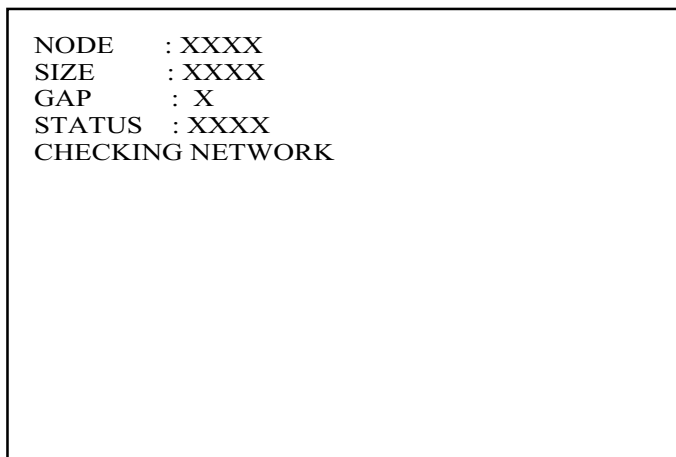

NETWORK check screen

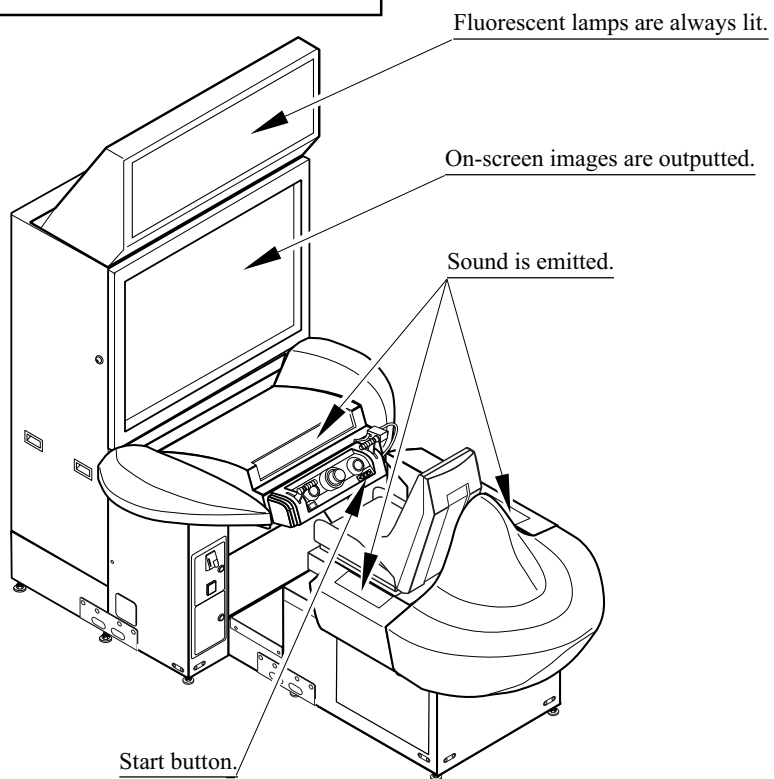

FIG 6. 5



### (3) SOUND TEST

```
SOUND TEST

MAIN SPEAKER LEFT
MAIN SPEAKER RIGHT
OPTION SPEAKER LEFT
OPTION SPEAKER RIGHT
> EXIT

SELECT WITH SERVICE BUTTON
AND
PRESS TEST BUTTON
```

In the system test mode, selecting SOUND TEST causes the screen (on which sound related BD and wiring connections are tested) to be displayed.

Check if the sound is satisfactorily emitted from each speaker and the sound volume is appropriate.

### (4) INPUT TEST

```
INPUT TEST

BOOST                OFF
BRAKE                OFF
LEFT BUTTON          OFF
RIGHT BUTTON         OFF
START                OFF

SERVICE             OFF
TEST                 OFF

LEFT LEVER           **
RIGHT LEVER          **

PRESS TEST AND SERVICE BUTTON TO EXIT
```

Selecting the INPUT TEST on the game test mode menu screen causes the screen (on which each switch is tested) to be displayed. Press each switch. For the coin switch test, insert a coin from the coin inlet with the coin chute door open. If the display beside each switch indicates "ON," the switch and wiring connections are satisfactory.

```
JVS TEST
> DISPLAY CONFIG
EXIT

NODE 1/1
SWITCH
SYSTEM _____
PLAYER1 _____
PLAYER2 _____
COIN
SLOT1 0000  SLOT2 8000
ANALOG
CH1 6300 CH2 5A00 CH3 7D00 CH4 8100
CH5 1F00 CH6 1D00 CH7 1F00 CH8 2000

SELECT WITH SERVICE BUTTON
AND
PRESS TEST BUTTON
```



(5) OUTPUT TEST

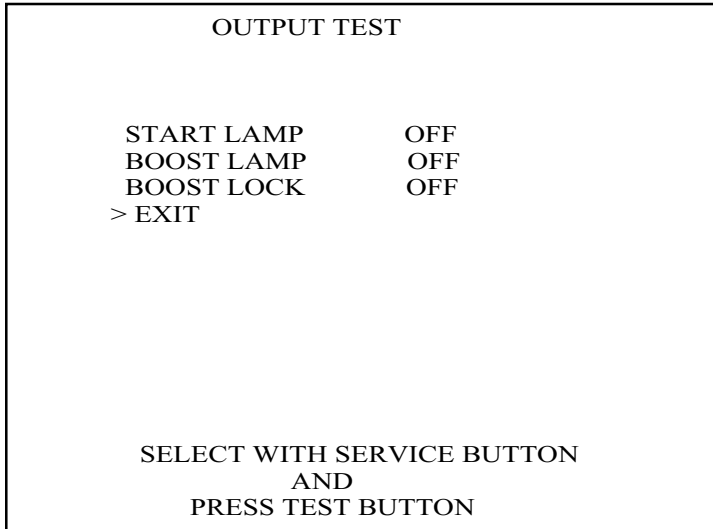

Select OUTPUT TEST from the Menu screen in the Game Test Mode to cause the screen (on which output unit such as lamps and wiring connections are tested) to appear. Ensure that the output unit functions satisfactorily.

Perform the above inspections also at the time of monthly inspection.

## 7. PRECAUTIONS TO BE HEHEDED WHEN MOVING THE MACHINE



WARNING!

- When moving the machine, be sure to unplug the power plug. Moving the machine with the plug as is inserted can damage the power cord and cause fire and electric shock hazards.
- When moving the machine on the floor, retract the Adjusters and ensure that Casters make contact with the floor. During transportation, pay careful attention so that Casters do not tread power cords and earth wires. Damaging the power cords can cause electric shock and short circuit hazards.
- When lifting the cabinet, be sure to hold the grip portions or bottom part. Lifting the cabinet by holding other portions can damage parts and installation portions due to the empty weight of the cabinet, and cause personal injury.
- When transporting the product in places with step-like differences in grade, disassemble into each unit before transporting. Lifting up the product in an attempt to cross the step-like differences in an as is assembled condition may damage the unit's joining portions and cause a personal injury resulting from damage.
- When moving the PTV, do not push it from the rear side. Push it from sideways. Pushing the PTV from the rear side can have the PTV fall down, causing personal injury etc. In case the floor has slanted surfaces or step-like differences, be sure to move the machine by 2 or more persons.
- Do not insert the fork to places other than designated when using a Forklift to transport the machine.  
Failure to observe this could cause falling down and injury resulting from falling down.



CAUTION!

Do not push the plastic made parts. Failure to observe this may damage parts and cause injury due to fragments resulting from damage.



IMPORTANT!

- When transporting the product in places with steps, disassemble into each unit before transporting. Inclining the product in an as is assembled condition or placing the cabinet in places with steps can damage the unit's joining portions.
- To protect surface, do not directly apply a rope to the surfaces of product. Use protective materials to the places the rope is applied to.



Do not push PTV from the back. Pushing the PTV from the back can cause the PTV to fall down. Push it from the side.

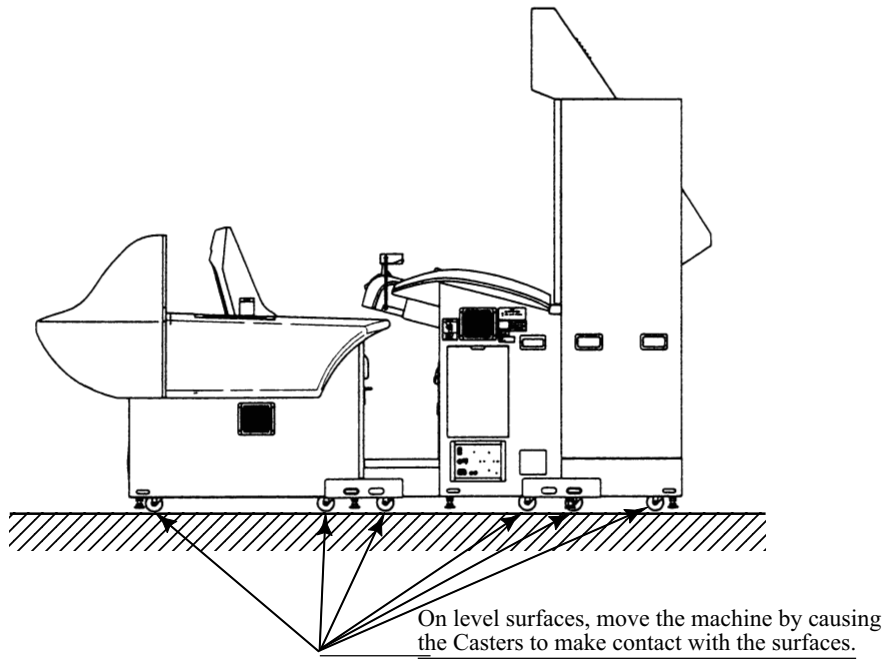

FIG. 7 a

When transporting the product in places with steps or step-like differences in grade, disassemble into each unit before transporting.

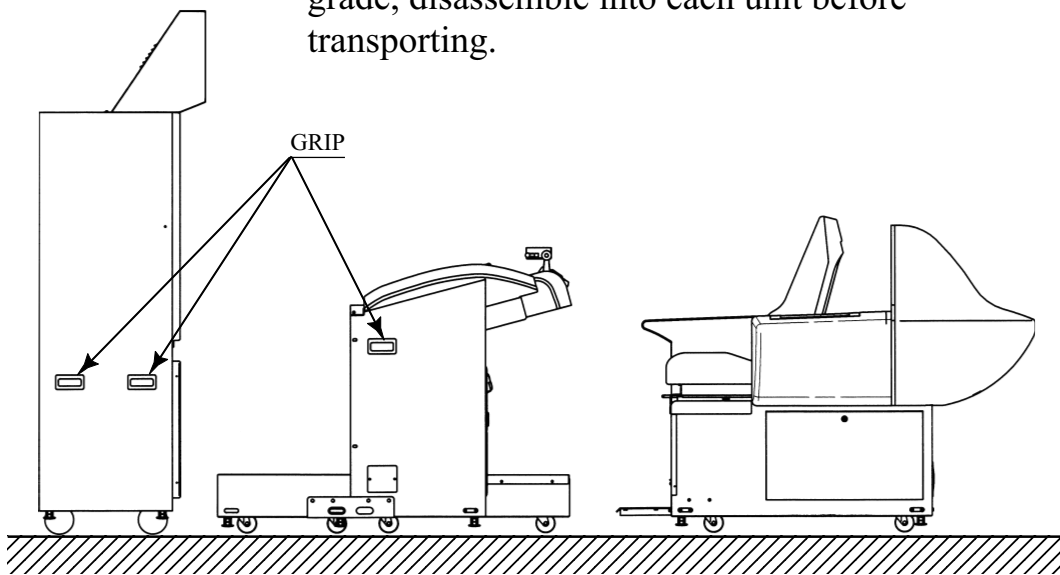

FIG. 7 b

## 8. CONTENTS OF GAME

The following explanations apply to the case the product is functioning satisfactorily. Should there be any moves different from the following contents, some sort of faults may have occurred. Immediately look into the cause of the fault and eliminate the cause thereof to ensure satisfactory operation.

When the product is energized, the Billboard's fluorescent lamp is always lit. During the advertise mode, advertise screen is shown on the monitor and sound is emitted from the speakers in the front, left and right of the seat. Setting to No Sound Output during the advertise is possible in the TEST mode. During the advertise mode, the button on the Control Panel is unlit.

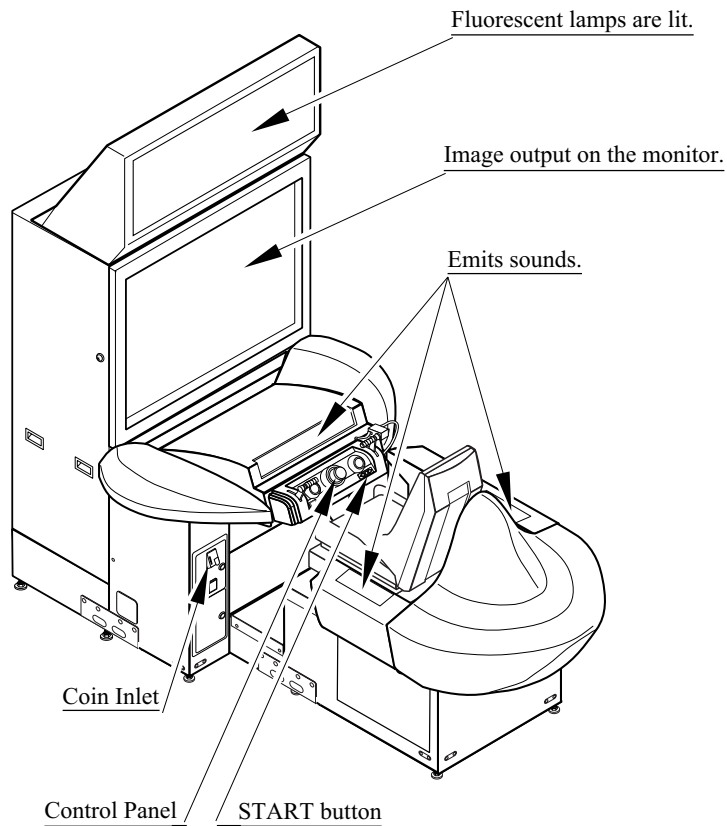

FIG. 8

## HOW TO PLAY

Get in the seat. To adjust the seat position forward and rearward, pull the lever under the seat in the right-hand side to release the seat lock.

The game starts upon inserting the one play-equivalent number of coins.

### SELECT SCREEN

For Communication Play:

When the communication play is set effective, the monitor screen remains stationary for approximately 10 seconds to wait for the participant. The time limit is displayed at the upper right screen. Press the START button to cancel vs. play and proceed to the 1P mode. During the first 3 seconds, to avoid miss operation, pressing the START button does not cancel vs. mode.

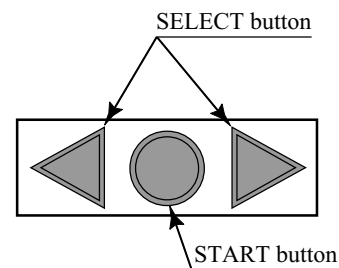

<"NOW WAITING FOR NEW ENTRY" screen>

Select one from among the 4 courses. Select the course with the SELECT button and press the START button to decide. The time limit for selecting the course is displayed at the upper right screen. The course indicated in the left is easier, and the difficulty is increased upon proceeding to the right side.

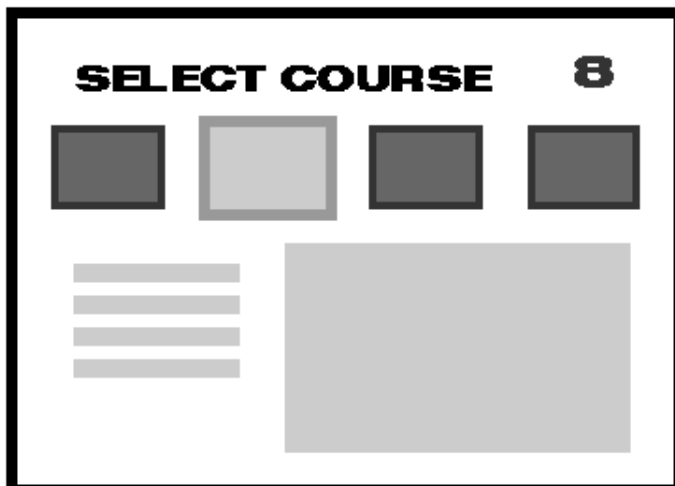

<"SELECT COURSE" screen>

Select one from among the 4 vehicles. Select the vehicle with the SELECT button and press the START button to decide. The time limit for selecting the vehicle is displayed at the upper right screen. There are only 2 types of vehicles usable at the time of shipment. However, by fulfilling the requirements described later in this manual, the remaining 2 vehicles can be available. Performance of each vehicle differs.

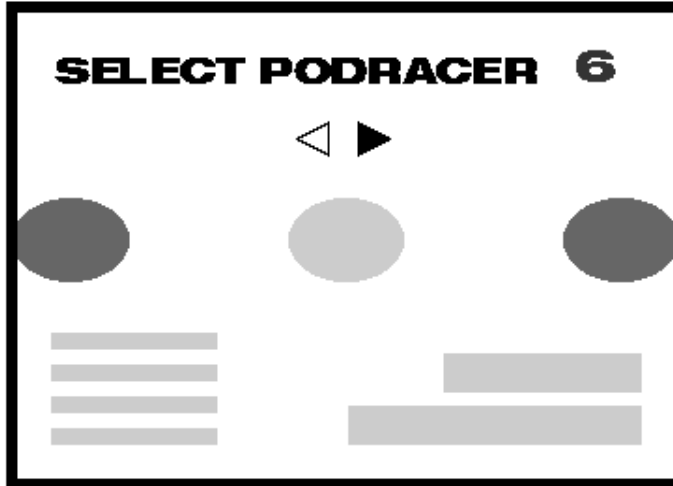

<"SELECT PODRACER" screen>

For Communication Play:

After selecting your vehicle, input your name in the 3 alphabet letters. The name inputted here is displayed at the upper of the opponent's vehicle in the game screen. Scroll the letter screen with the SELECT button and press the START button to decide. Finally select the END to confirm. The time limit for inputting your name is displayed at the upper right screen. Upon completion of name input by all players, the monitor proceeds to the next screen.

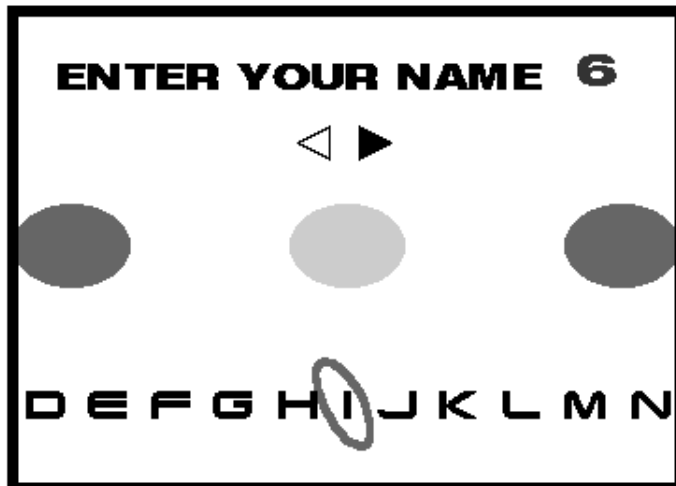

<"ENTER YOUR NAME" screen>

While loading the game data, the screen remains stationary for a while. You cannot skip this screen.

## ■ COURSES and VEHICLES

There are 4 courses in this product.

### [BANTHA TRACKS] EASY

The actual course shown in the motion picture has been simplified and shortened for the beginners. The huge rocks rise out of the stretched wilderness.

### [SMUGGLER'S COVE] NORMAL

The beautiful scenery of a shoal and land covered with moss can be seen in this course. Although you will face consecutive curves in the course, the difficulty itself is not too high.

### [PIXELITO CHALLENGE] HARD

The stage in this course is the mountains by night. The narrower road and the number of hairpin curves make it the most difficult among the 4 courses in terms of the course layout.

### [THE BOONTA CLASSIC] EXPERT

The courses shown in the motion picture have been reproduced in this course. The length of the course is longer than the other 3 courses, and this makes it difficult to stay the course.

There are 4 kinds of vehicles that can be used. The 2 of them can be usable if the certain requirements are fulfilled. Therefore, the vehicles available at the beginning are the ANAKIN SKYWALKER and the SEBULBA.

Conditions to have the hidden vehicle appear.

[GASGANO] When exceeded 700 plays in total (at any course/character).

[BEN QUADINAROS] In the EXPERT course, when game is finished for 50 times or more (at any character).

Note that once the items appear, although the BACKUP RAM CLEAR is performed, they will not be cleared.

## ■ HOW TO OPERATE

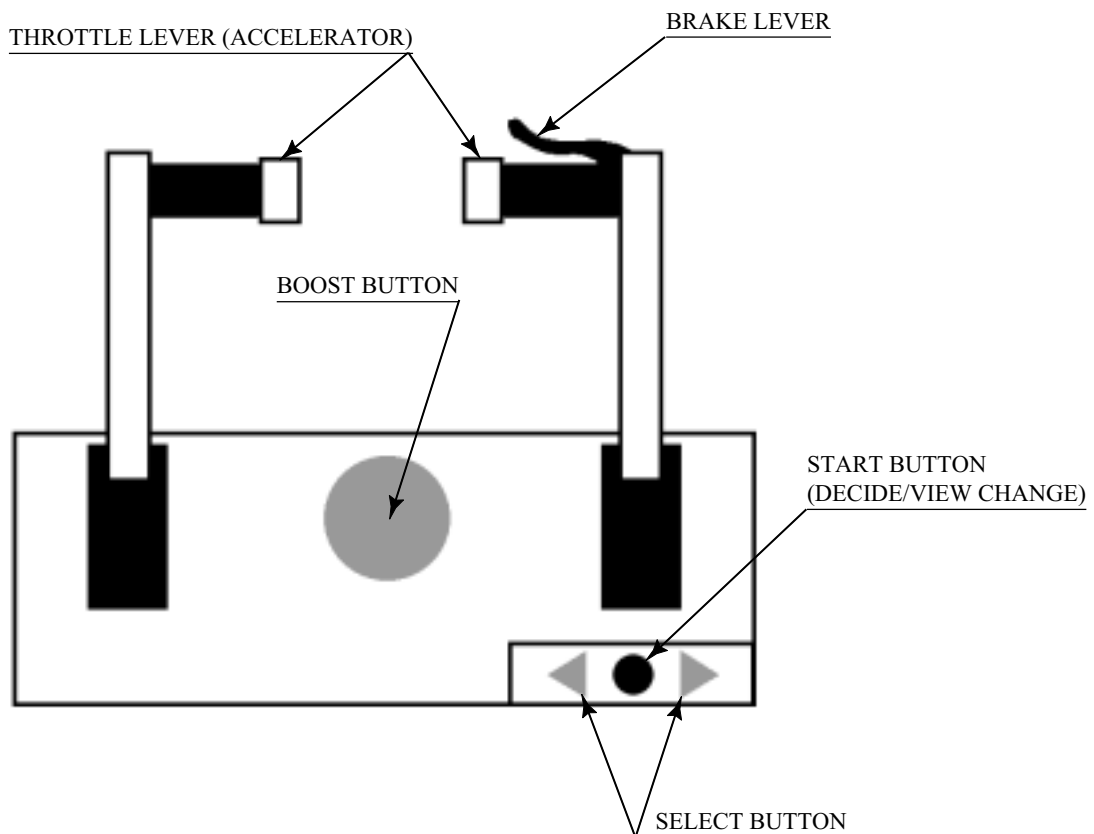

The THROTTLE LEVER left & right also function as an accelerator and steering. Incline the THROTTLE LEVER forward to gain speed. To reduce the speed, pull the THROTTLE LEVER toward you. To turn right, incline the left Lever forward and pull the right Lever toward you. Incline the right Lever forward and pull the left Lever toward you to turn left. Grip the Brake Lever on the right-hand Lever to quickly reduce the speed. The Brake Lever itself is in the digital switch system, however, braking power varies in accordance with the strength of gripping the Lever.

Press the BOOST button on the center of the panel to gain a rapid speed for a certain period of time. The gauge displayed at the lower right screen shows the current BOOST effect. The BOOST power gradually diminishes, and when it becomes zero, acceleration is finished. While the BOOST is in effect, the button is kept pressed down. Once the BOOST becomes active, the button returns to its original state.

Note that setting of not performing the aforementioned operation can be selected (9-3D).

In that case however, gaining a rapid speed by the BOOST button remains unchanged.

BOOST can be used up to 3 times per race. The BOOST button goes on when active, flashes during use, and goes off when inactive.

The START button can be used for "DECIDE" in the select screen and "VIEW CHANGE" during game. It goes on during the race only.

Use the SELECT button for selecting the course, the vehicle, and the letters in the NAME entry.

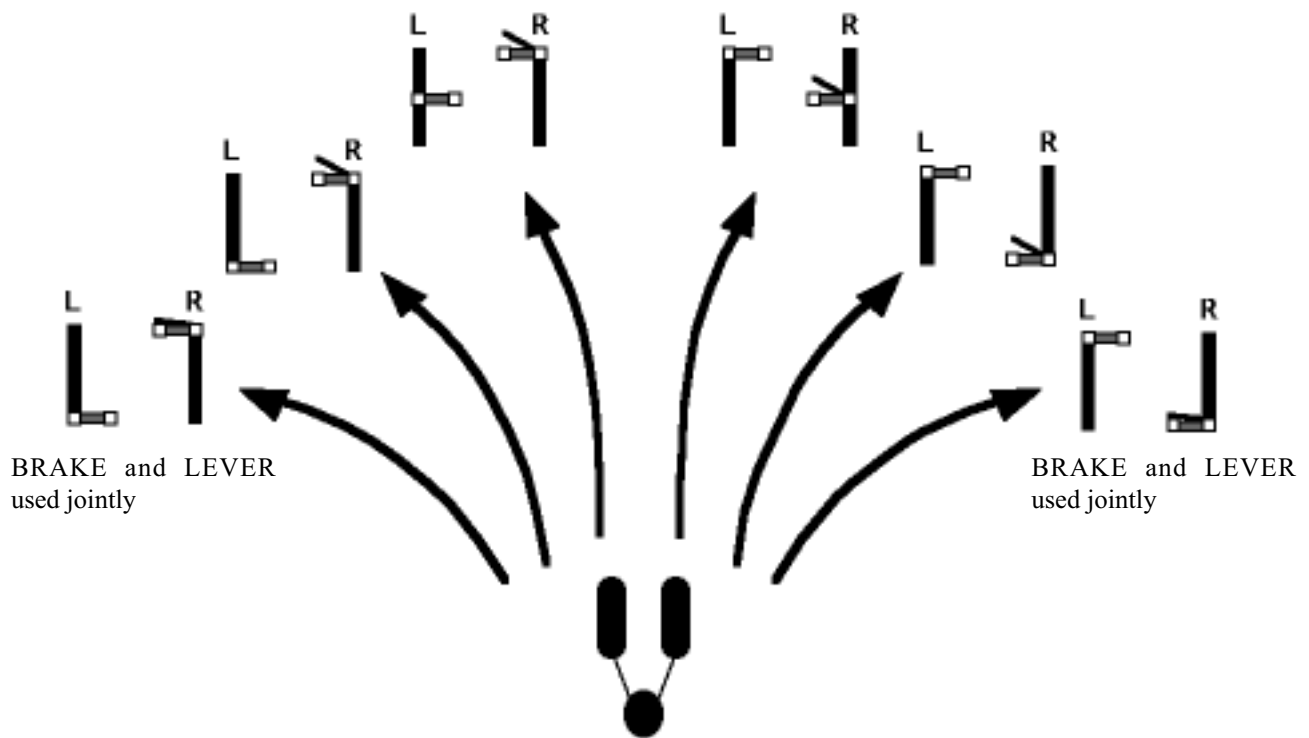

OPERATION - EFFECT of the LEVER



## ■ GAME SCREEN

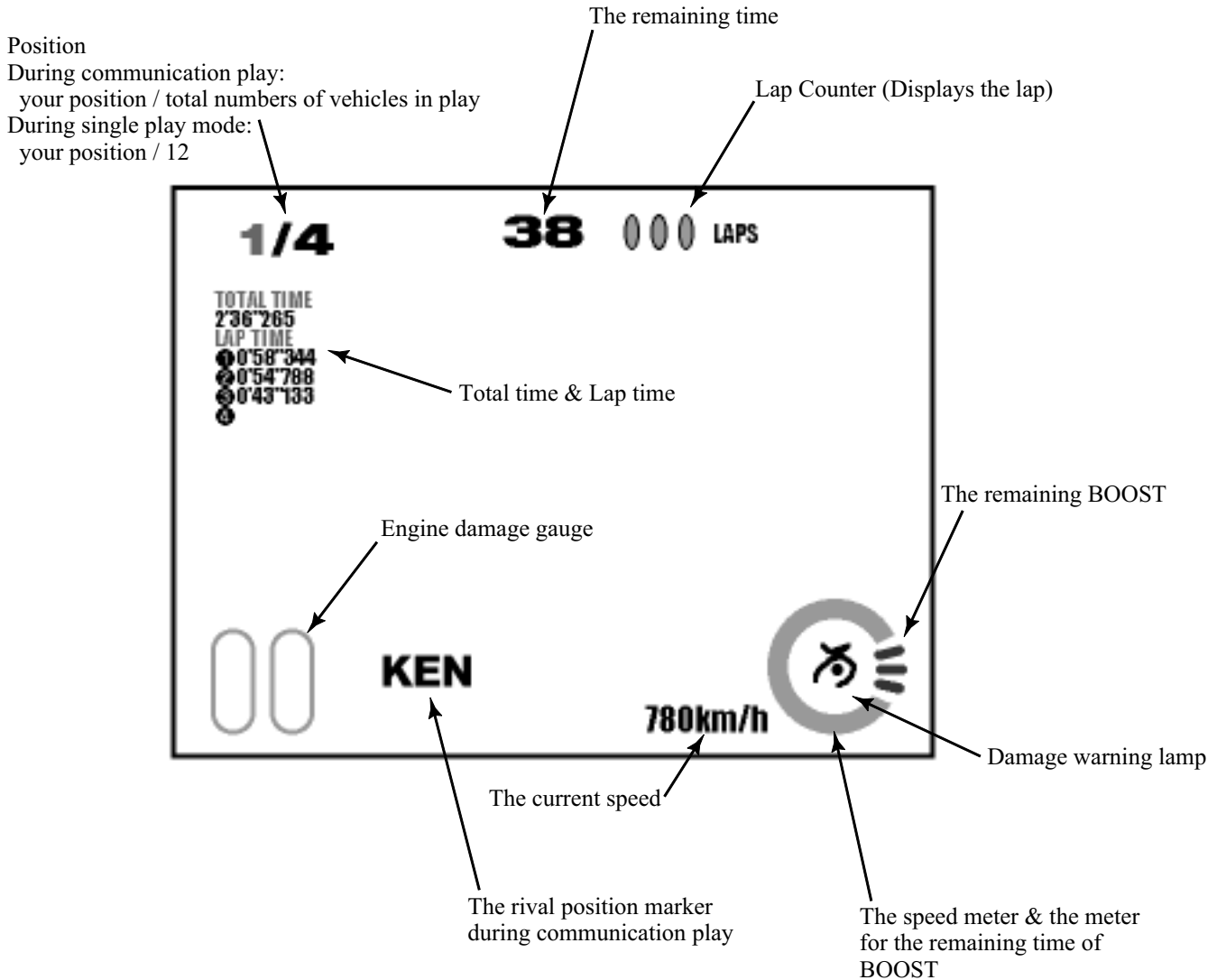

## ■ GAME OVER

The purpose is to finish the predetermined number of laps within the time limit. There are 3 laps in the EXPERT course and 4 in the other courses. When the remaining time becomes zero, you have to retire unfinished. Pass through the checkpoints on the course, and you can get extra time. When the first position player goes through the checkpoint, extra time is given to other players. The same applies to communication play.

## ■ DAMAGE SYSTEM

When hitting or making contact with obstacles, damage increases and the gauge displayed at the lower left screen turns yellow. Recovery is possible if you do not hit or make contact with them thereafter. When damage reaches the maximum, the gauge turns red and BOOST cannot be used due to the limitation applied to the maximum speed. The condition can automatically be restored, however, it takes approximately 10 seconds to do so.

## NAME ENTRY

The NAME ENTRY screen where you can input your name up to 3 letters will be displayed on the following conditions:

- (1) In 1P mode, when the player's record is excellent. (after race)
- (2) In 1P mode, when the player is finished within the first to the third position. (after race)
- (3) Communication (vs.) play is formed. (before race)

Scroll the letter screen with the SELECT button and press the START button to decide. After inputting the 3 letters, bring the cursor to "END" and press the START button to decide.

In case of (1) as above, after the name entry, the rank will be displayed.

In case of (2) as above, the name entry is for making password for the Internet ranking registration. Therefore, the name will not necessarily be displayed for in-game ranking.

## CONTINUOUS VS. PLAY

In vs. play, while the game over screen is displayed, you are asked if you continue vs. play. The countdown is displayed at the same time. If 2 or more players insert coins before countdown reaches zero, continuous vs. play is effective, and vs. play record in total is displayed. Note that "P1 ~ P4" as above displays the seat numbers set in the TEST MODE.



<GAME OVER screen after vs. play>

## PASSWORD

When you succeed to run the whole distance in 1P mode in any course, the password screen will be displayed. Make a note of the password shown in the screen and send it to the Home Page exclusive for this game, and you can enter in the world ranking register. You can skip this screen by pressing the START button. The Home Page has been open since May 2000. Operation and maintenance in the second year and thereafter are undecided, however.  
URL: <http://www.sega.co.jp/racer/>

## FLOW CHART

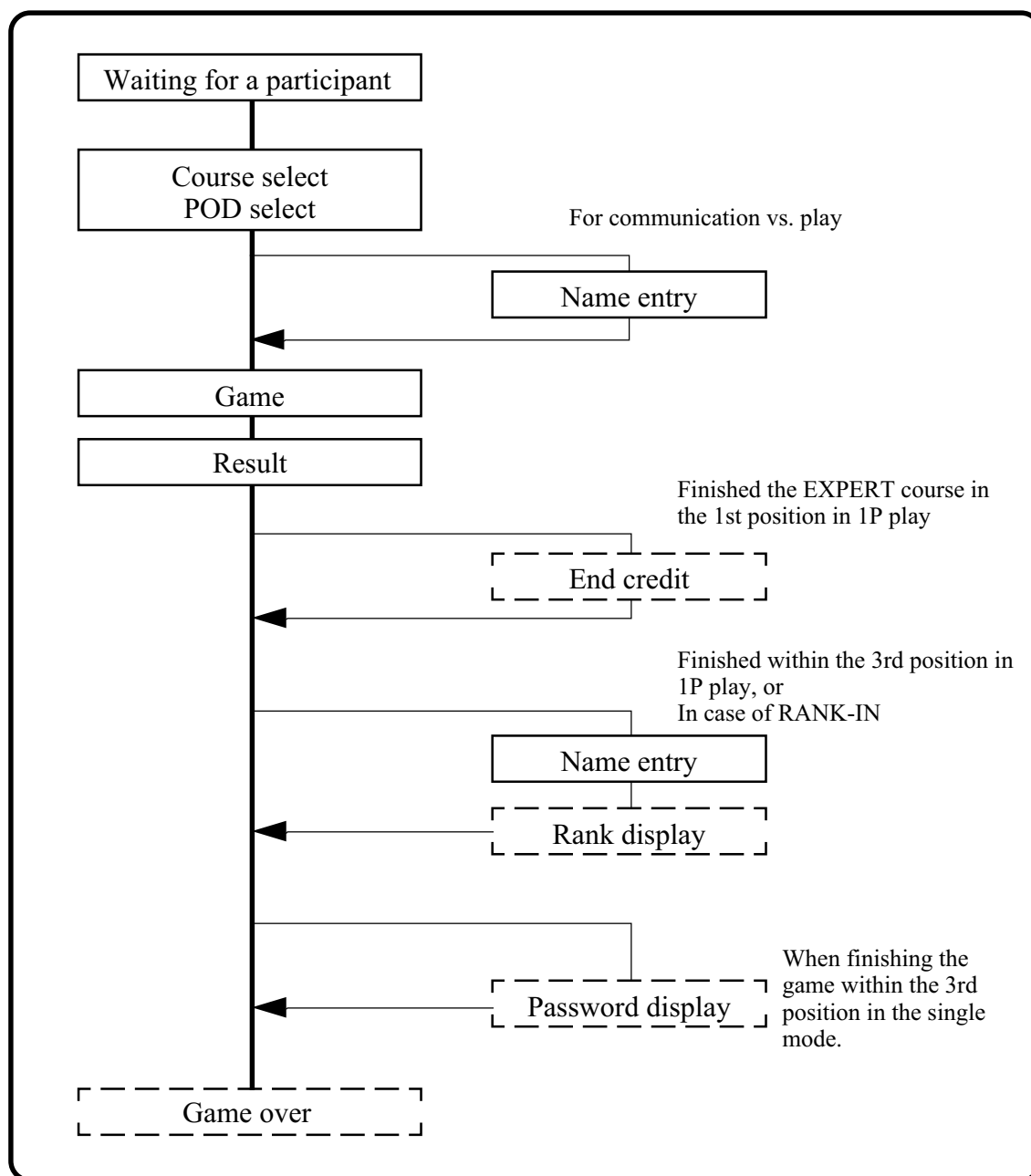

You can skip the items enclosed with a dot line in the above chart with the START button.

## 9. EXPLANATION OF TEST AND DATA DISPLAY

By operating the switch unit, periodically perform the tests and data check. When installing the machine initially or collecting cash, or when the machine does not function correctly, perform checking in accordance with the explanations given in this section.

The following shows tests and modes that should be utilized as applicable.

SEGA HIKARU GAME BOARD is used for the product. The system of this game board allows another game to be played by replacing the ROM Board Case mounted on the SEGA HIKARU CASE. As such, the Test Mode of this system consists of the System Test Mode for the system to execute SELF-TEST, COIN ASSIGNMENTS, etc. used in common for the machines employing the SEGA HIKARU BOARD, and the Game Test Mode for the specific product to execute Input/Output test for the operation equipment, difficulty setting, etc.



IMPORTANT!

- The contents of settings changed in the TEST mode are stored when the test mode is finished from EXIT in the menu mode. If the power is turned off before the TEST mode is finished, the contents of setting change become ineffective.
- Executing "BACKUP DATA CLEAR" in the SYSTEM TEST MODE does not clear the BOOKKEEPING data in the GAME TEST mode.
- Entering the TEST mode clears fractional number of coins less than one credit and BONUS ADDER data.
- When the 2 or more machines are linked for communication play, be careful to enter the test mode. If one of the machines linked enters the test mode, all others display the NETWORK CHECK screen.

TABLE 9 EXPLANATION OF TEST MODE

ITEMS	DESCRIPTION	REFERENCE SECTIONS
INSTALLATION OF MACHINE	When the machine is installed, perform the following: <ol style="list-style-type: none"> <li>1. Check to see that each setting is as per standard setting made at the time of shipment.</li> <li>2. In the INPUT TEST mode, check such input devices as each SW, V.R., etc.</li> <li>3. In the OUTPUT TEST mode, check such output devices as lamps, motors, etc.</li> <li>4. In the SELF-TEST mode, check ICs on the IC Board.</li> </ol>	9-2 F,G, 9-3 D 9-2 C, 9-3 B 9-3 C 9-2 B,J
MEMORY	Choose MEMORY TEST in the MENU mode to allow the MEMORY test to be performed. In this test, PROGRAM RAMs, ROMs, and ICs on the IC Board are checked.	9-2 B,J
PERIODIC SERVICING	Periodically perform the following: <ol style="list-style-type: none"> <li>1. MEMORY TEST</li> <li>2. Ascertain each setting.</li> <li>3. In the INPUT TEST mode, test the CONTROL device</li> <li>4. In the OUTPUT TEST mode, check such output devices as lamps, motors, etc.</li> </ol>	9-2 B,J 9-2 F,G, 9-3 D 9-2 C, 9-3 B 9-3 C
CONTROL SYSTEM	<ol style="list-style-type: none"> <li>1. In the INPUT TEST mode, check such input devices as each SW, V.R., etc.</li> <li>2. Adjust or replace each SW and VR.</li> <li>3. If the problem can not be solved yet, check the CONTROL's moves.</li> </ol>	9-2 C, 9-3 B 9-3 F, 10
MONITOR	In the MONITOR ADJUSTMENT mode, check to see if the PROJECTOR adjustment is appropriately made.	9-2 E 12
IC BOARD	<ol style="list-style-type: none"> <li>1. MEMORY TEST</li> <li>2. In the SOUND TEST mode, check the sound related ROMs.</li> </ol>	9-2 B,J 9-2 D
DATA CHECK	Check such data as game play time and histogram to adjust the difficulty level, etc.	9-2 H, 9-3 E

9 - 1 SWITCH UNIT AND COIN METER



WARNING!

Never touch places other than those specified. Touching places not specified can cause electric shock and short circuit hazards.



IMPORTANT

- Adjust to the optimum sound volume by considering the environmental requirements of the installation location.
- If the COIN METER and the game board are electrically disconnected, game play is not possible.

SWITCH UNIT

Open the coin chute door, and the switch unit shown will appear.  
The functioning of each SW is as follows:

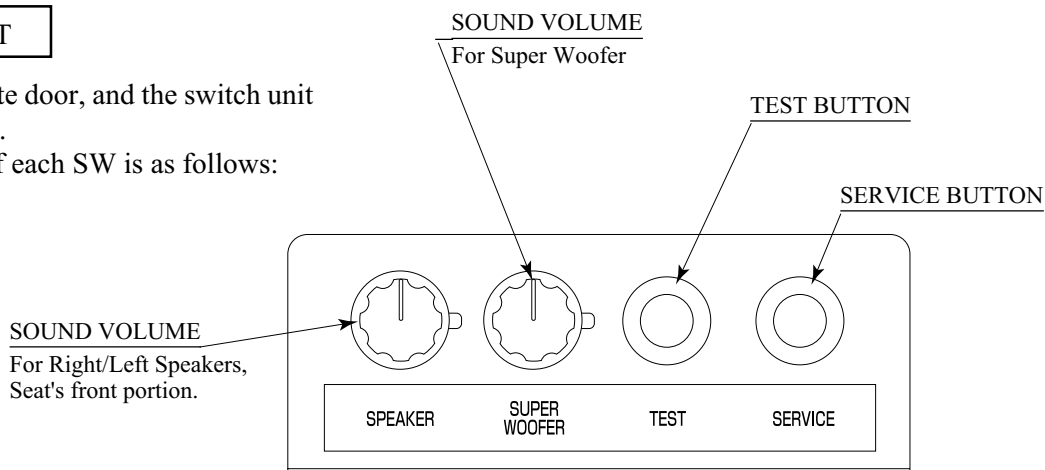

FIG. 9. 1 a SWITCH UNIT

VOLUME INSIDE THE SIDE DOOR OF THE REAR CABI

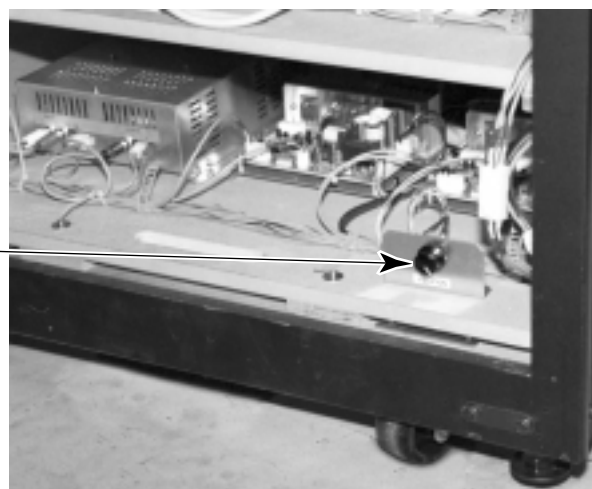

PHOTO 9. 1

SOUND VOLUME CONTROL :  
SOUND

SOUND VOLUME CONTROL :  
WOOFER

VOLUME INSIDE THE SIDE DOOR OF THE REAR CABI :  
VIBRATION

TEST BUTTON :  
TEST

SERVICE BUTTON :  
SERVICE

Adjusts the Right/Left Speakers at the Seat's front portion.

Adjusts the Super Woofer at the Seat's back portion.

Adjusts the output of the Control Panel's vibration device.

For the handling of the test button, refer to the following pages.

Gives credits without registering on the coin meter.

COIN METER

Open the Cashbox Door by using the key to have the Coin Meter appear underneath the Cashbox.

COIN METER

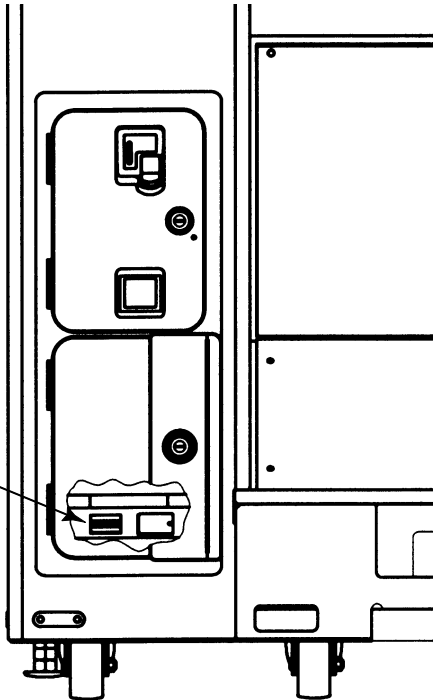

FIG. 9. 1 b

## 9 - 2 SYSTEM TEST MODE

### A. SYSTEM TEST MODE MENU

Press TEST Button to enter the TEST MODE, and the following Menu screen will be displayed.

```
SYSTEM MENU
X X X X X VERSION

RAM TEST
JVS TEST
SOUND TEST
C.R.T. TEST
SYSTEM ASSIGNMENTS
COIN ASSIGNMENTS
BOOKKEEPING
BACKUP DATA CLEAR
ROMBD TEST
CLOCK SETTING
GAME TEST MODE
> EXIT

SELECT WITH SERVICE BUTTON
AND
PRESS TEST BUTTON
```

- Press SERVICE Button to move the arrow (>) to the desired item and select with TEST Button.
- Bring the arrow to EXIT and press TEST Button to return to the GAME Mode.

### B. RAM TEST

This allows for checking the functioning of the RAM on the Game BD.

In this test, IC's are checked in every row. During the test, "CHECKING" is displayed at the right-hand side of the screen. "BAD" is indicated for irregular RAMs, if any.

Upon finishing the test, "PRESS TEST BUTTON TO EXIT" is displayed on the lower center of the monitor. Press TEST Button to return to the MENU screen.

```
RAM TEST

IC15 IC16 IC17S IC18S GOOD
IC22 IC23 IC24S IC25S GOOD
IC28 IC29S          GOOD
IC41                GOOD
IC42                GOOD
IC44 IC45S IC46 IC47S GOOD
IC91S IC92S         GOOD
IC98                GOOD

OPTIONAL SOUND BOARD:
IC12                GOOD

OPTIONAL COMMUNICATION BOARD:
IC7 IC8 IC9 IC10   GOOD
.
.
.

PRESS TEST BUTTON TO EXIT
```



### C. JVS TEST

```
      JVS TEST
      INPUT TEST
      > EXIT

NODE    1/1
NAME    SEGA ENTERPRISES,LTD.;I/O BD JVS;
        837-13551 ;Ver1.00;98/10
CMD VER  1.1
JVS VER  2.0
COM VER  1.0
SWITCH  2PLAYERS 13BITS
COIN    2SLOTS
ANALOG  8CH
DRIVER OUT 6CH

      SELECT WITH SERVICE BUTTON
      AND
      PRESS TEST BUTTON
```

In this test, Functioning of the I/O Board connected to Game Board is displayed and INPUT TEST can be performed. Execute EXIT to return to the MENU screen.

When INPUT TEST is selected and executed, the following screen appears.

```
      JVS TEST
      > DISPLAY CONFIG
      EXIT

NODE    1/1
SWITCH
SYSTEM  _____
PLAYER1 _____
PLAYER2 _____
COIN
SLOT1 0000 SLOT2 8000
ANALOG
CH1 6300 CH2 5A00 CH3 7D00 CH4 8100
CH5 1F00 CH6 1D00 CH7 1F00 CH8 2000

      SELECT WITH SERVICE BUTTON
      AND
      PRESS TEST BUTTON
```

When INPUT is performed, the Switch value changes to 1 from \_ . Execute EXIT to return to the MENU screen.

## D. SOUND TEST

Sound Output can be performed and each Speaker can be checked.

<p>SOUND TEST</p> <p>MAIN SPEAKER LEFT MAIN SPEAKER RIGHT OPTION SPEAKER LEFT OPTION SPEAKER RIGHT &gt; EXIT</p> <p>SELECT WITH SERVICE BUTTON AND PRESS TEST BUTTON</p>
--

Select the desired item and press TEST Button, and sound is emitted from the corresponding Speaker. The OPTIONAL SPEAKER LEFT and RIGHT function the same. Select either OPTIONAL SPEAKER LEFT or RIGHT to allow the vibration device of the Control Panel to be checked. Execute EXIT to return to the MENU screen.

## E. C.R.T. TEST

In this test, monitor adjustment can be performed. Periodically check to see if the monitor adjustment is appropriate in this test. This test consists of 2 screens. Use SERVICE Button to change the screen displayed. Press TEST Button to return to the MENU screen.

<p>C.R.T. TEST PAGE#1</p> <p>0<span style="float: right;">31</span></p> <table border="1" style="width: 100%;"><tr><td style="text-align: center;">RED</td></tr><tr><td style="text-align: center;">GREEN</td></tr><tr><td style="text-align: center;">BLUE</td></tr><tr><td style="text-align: center;">WHITE</td></tr></table> <p>PRESS SERVICE BUTTON TO ANOTHER PAGE PRESS TEST BUTTON TO EXIT</p>	RED	GREEN	BLUE	WHITE
RED				
GREEN				
BLUE				
WHITE				

The first screen displays color bars. The color adjustment can be checked. Each of red, green, blue is the darkest at the leftmost end, and becomes brighter towards the right-hand end.

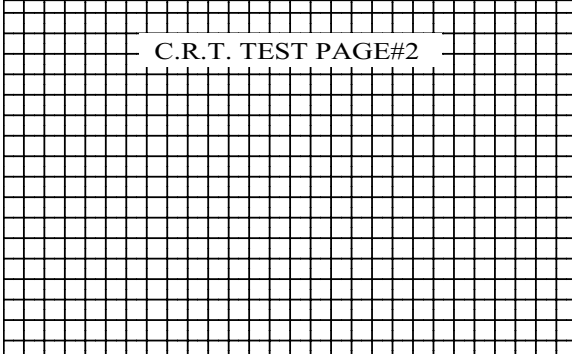
<p>C.R.T. TEST PAGE#2</p>  <p>PRESS SERVICE BUTTON TO ANOTHER PAGE PRESS TEST BUTTON TO EXIT</p>
---

The second screen displays crosshatches. In this page, monitor size and deviation can be checked.

## F. SYSTEM ASSIGNMENTS

Performs setting for the whole system. Set each item in accordance with the cabinet. Use the items except ADVERTISE SOUND and COMMUNICATION MODE as they are at the time of shipment. To change setting, bring the arrow (>) to the desired item with the SERVICE button and press the TEST button.

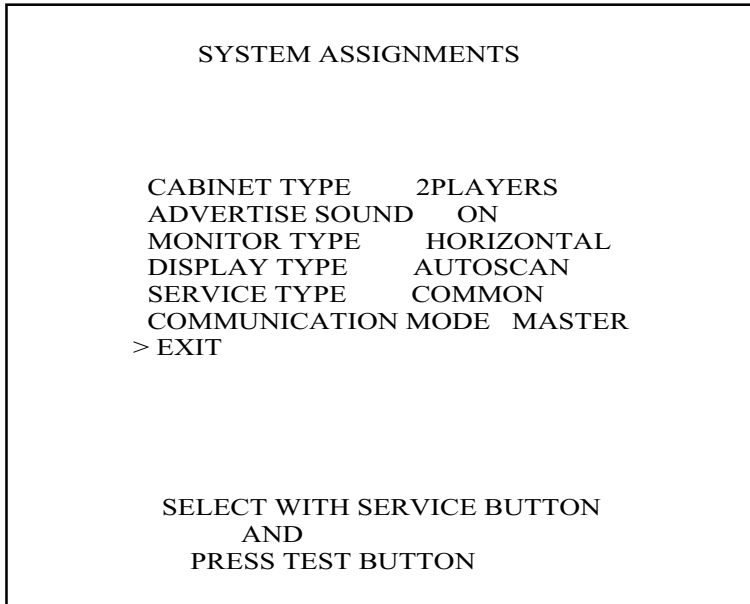

- CABINET TYPE specifies Control Panel and number of Coin Chute. The number of Player displayed in BOOKKEEPING varies in accordance with the value here.
- ADVERTISE SOUND is used for settings of emitting sound during ADVERTISE.
- MONITOR TYPE sets the on-screen display to the positional direction of monitor (HORIZONTAL or VERTICAL). If set to VERTICAL, the on-screen display for the test mode is vertically positioned in accordance with the setting.
- DISPLAY MODE sets the monitor's display frequency. In this mode, if other than AUTOSCAN is selected and EXIT is executed, the display frequency is changed to the selected setting.
- SERVICE TYPE sets the functioning of when the Service Button is pressed, in case that several Service Buttons exist.
  - INDIVIDUAL  
By pressing Service Button, Service credit can be obtained for the Player corresponding to the Service Button pressed.
  - COMMON  
By pressing any Service Button, Service credit can be obtained for all Players.

- COMMUNICATION MODE is for communication play setting. Select from among MASTER, SLAVE, NO LINK, and RELAY. When performing setting for communication play, be careful of the following points.

MASTER : Set only one of the linked machine to MASTER for communication play.

SLAVE : Set the other linked machines to SLAVE for communication play.

NO LINK : Set to NO LINK when you operate the machine alone.

RELAY : Set to RELAY when you want to use the machine as a monitor showing the communication play.

[SEAT NUMBER]

Give a different seat number to each of the MASTER and SLAVE machines linked for communication play. If the same numbers are used among the linked machines, game does not start. (Refer to 9-3 D. GAME ASSIGNMENTS)

[The following setting items in the MASTER apply to the SLAVE.]

- ADVERTISE SOUND ON/OFF (SYSTEM MENU)
- DIFFICULTY SETTING (GAME TEST MODE)
- Object / Subject View of Default View (GAME TEST MODE)
- URL display ON/OFF during ADVERTISE (GAME TEST MODE)
- Hidden vehicles that are usable

When set to NO LINK, each machine's individual setting value is applied.

## G. COIN ASSIGNMENTS

In this mode, the setting of incremental credit increase as against coin insertion can be changed. This test consists of 3 screens, and the following is the first screen. The setting done in the first screen will be stored when exited.

```

          COIN ASSIGNMENTS
COIN CHUTE TYPE      COMMON
COIN/CREDIT SETTING  #1
COIN CHUTE #1
    1COIN 1CREDIT

COIN CHUTE #2
    1COIN 1CREDIT

MANUAL SETTING
SEQUENCE SETTING
> EXIT

SELECT WITH SERVICE BUTTON
      AND
PRESS TEST BUTTON
```

- COIN CHUTE TYPE sets whether Coin Chute is used in common by all players or separately allocated to each player in case 2 or more Coin Chutes are incorporated.  
COMMON: This setting is for common use by plural players.  
INDIVIDUAL: As each player uses an independent coin chute, setting to INDIVIDUAL causes COIN CHUTE #2 to be disappeared.
- COIN/CREDIT SETTING is set when using one of the existing 26 settings or FREE PLAY. The selected coin rates in the COIN/CREDIT SETTING are displayed below COIN CHUTE #1 and COIN CHUTE #2. If you wish to set a coin rate rather than to select from the existing setting, select MANUAL SETTING. The display next to COIN/CREDIT SETTING indicates "MANUAL", not "#n" in this case.

○ MANUAL SETTING

When MANUAL SETTING is selected in the first screen, the following second screen appears.

COIN ASSIGNMENTS	
MANUAL SETTING	
COIN TO CREDIT	1
BONUS ADDER	0
COIN CHUTE #1 MULTIPLIER	
1 COINCOUNT AS 1COIN	
COIN	1 2 3 4 5 6 7 8 9
CREDIT	1 2 3 4 5 6 7 8 9
COIN CHUTE #2 MULTIPLIER	
1 COINCOUNT AS 1COIN	
COIN	1 2 3 4 5 6 7 8 9
CREDIT	1 2 3 4 5 6 7 8 9
SEQUENCE SETTING	
> EXIT	
SELECT WITH SERVICE BUTTON	
AND	
PRESS TEST BUTTON	

- COIN TO CREDIT determines how many coins are needed for one credit. (1 ~ 9)
- BONUS ADDER determines how many coins should be inserted to obtain one SERVICE COIN.
- COIN CHUTE #1 MULTIPLIER, COIN CHUTE #2 MULTIPLIER sets how many tokens one Coin represents inserted in each COIN CHUTE.

SETTING EXAMPLE 1)

Setting of 2 COINS 1 CREDIT, set to:

COIN TO CREDIT	:2
BONUS ADDER	:0
COIN CHUTE #1 MULTIPLIER	:1

SETTING EXAMPLE 2)

Setting of 5 COINS 6 CREDITS (5 COINS 1 BONUS), set to

COIN TO CREDIT	:1
BONUS ADDER	:5
COIN CHUTE #1 MULTIPLIER	:1

When exiting from MANUAL SETTING, if the identical coin rate is in the existing COIN/ CREDIT SETTING, such existing mode other than what is set in the MANUAL SETTING is confirmed.

TABLE 1 COIN/CREDIT SETTING

NAME OF SETTING	FUNCTIONING OF COIN CHUTE #1		FUNCTIONING OF COIN CHUTE #2	
SETTING #1	1 COIN	1 CREDIT	1 COIN	1 CREDIT
SETTING #2	1 COIN	2 CREDITS	1 COIN	1 CREDIT
SETTING #3	1 COIN	3 CREDITS	1 COIN	1 CREDIT
SETTING #4	1 COIN	4 CREDITS	1 COIN	1 CREDIT
SETTING #5	1 COIN	5 CREDITS	1 COIN	1 CREDIT
SETTING #6	1 COIN	2 CREDITS	1 COIN	2 CREDITS
SETTING #7	1 COIN	5 CREDITS	1 COIN	2 CREDITS
SETTING #8	1 COIN	3 CREDITS	1 COIN	3 CREDITS
SETTING #9	1 COIN	4 CREDITS	1 COIN	4 CREDITS
SETTING #10	1 COIN	5 CREDITS	1 COIN	5 CREDITS
SETTING #11	1 COIN	6 CREDITS	1 COIN	6 CREDITS
SETTING #12	2 COINS	1 CREDIT	2 COINS	1 CREDIT
SETTING #13	1 COIN	1 CREDIT	2 COINS	1 CREDIT
SETTING #14	1 COIN	2 CREDITS	2 COINS	1 CREDIT
SETTING #15	1 COIN	1 CREDIT	1 COIN	1 CREDIT
	2 COINS	3 CREDITS	2 COINS	3 CREDITS
SETTING #16	1 COIN	3 CREDITS	1 COIN	1 CREDIT
			2 COINS	3 CREDITS
SETTING #17	3 COINS	1 CREDIT	3 COINS	1 CREDIT
SETTING #18	4 COINS	1 CREDIT	4 COINS	1 CREDIT
SETTING #19	1 COIN	1 CREDIT	1 COIN	1 CREDIT
	2 COINS	2 CREDITS	2 COINS	2 CREDITS
	3 COINS	3 CREDITS	3 COINS	3 CREDITS
	4 COINS	5 CREDITS	4 COINS	5 CREDITS
SETTING #20	1 COIN	5 CREDITS	1 COIN	1 CREDIT
			2 COINS	2 CREDITS
			3 COINS	3 CREDITS
			4 COINS	5 CREDITS
SETTING #21	5 COINS	1 CREDIT	5 COINS	1 CREDIT
SETTING #22	1 COIN	2 CREDITS	3 COINS	1 CREDIT
			5 COINS	2 CREDITS
SETTING #23	2 COINS	1 CREDIT	2 COINS	1 CREDIT
	4 COINS	2 CREDITS	4 COINS	2 CREDITS
	5 COINS	3 CREDITS	5 COINS	3 CREDITS
SETTING #24	1 COIN	3 CREDITS	2 COINS	1 CREDIT
			4 COINS	2 CREDITS
			5 COINS	3 CREDITS
SETTING #25	1 COIN	1 CREDIT	1 COIN	1 CREDIT
	2 COINS	2 CREDITS	2 COINS	2 CREDITS
	3 COINS	3 CREDITS	3 COINS	3 CREDITS
	4 COINS	4 CREDITS	4 COINS	4 CREDITS
	5 COINS	6 CREDITS	5 COINS	6 CREDITS
SETTING #26	1 COIN	6 CREDITS	1 COIN	1 CREDIT
			2 COINS	2 CREDITS
			3 COINS	3 CREDITS
			4 COINS	4 CREDITS
			5 COINS	6 CREDITS
SETTING #27	FREE PLAY		FREE PLAY	

Table 2: COIN/CREDIT SETTING (COIN CHUTE INDIVIDUAL TYPE)

NAME OF SETTING	EACH SEAT'S COIN CHUTE	NAME OF SETTING	EACH SEAT'S COIN CHUTE
SETTING #1	1 COIN 1 CREDIT	SETTING #21	5 COINS 1 CREDIT
SETTING #2	1 COIN 2 CREDITS	SETTING #23	2 COINS 1 CREDIT
SETTING #3	1 COIN 3 CREDITS		4 COINS 2 CREDITS
SETTING #4	1 COIN 4 CREDITS		5 COINS 3 CREDITS
SETTING #5	1 COIN 5 CREDITS	SETTING #25	1 COIN 1 CREDIT
SETTING #11	1 COIN 6 CREDITS		2 COINS 2 CREDITS
SETTING #12	2 COINS 1 CREDIT		3 COINS 3 CREDITS
SETTING #15	1 COIN 1 CREDIT 2 COINS 3 CREDITS		4 COINS 4 CREDITS 5 COINS 6 CREDITS
SETTING #17	3 COINS 1 CREDIT	SETTING #27	FREE PLAY
SETTING #18	4 COINS 1 CREDIT		
SETTING #19	1 COIN 1 CREDIT 2 COINS 2 CREDITS 3 COINS 3 CREDITS 4 COINS 5 CREDITS		

Table 3: MANUAL SETTING

COIN TO CREDIT	1 COIN 1 CREDIT
	2 COINS 2 CREDIT
	3 COINS 3 CREDIT
	4 COINS 4 CREDIT
	5 COINS 5 CREDIT
	6 COINS 6 CREDIT
	7 COINS 7 CREDIT
	8 COINS 8 CREDIT
	9 COINS 9 CREDIT
BONUS ADDER	NO BONUS ADDER
	2 COINS GIVE 1 EXTRA COIN
	3 COINS GIVE 1 EXTRA COIN
	4 COINS GIVE 1 EXTRA COIN
	5 COINS GIVE 1 EXTRA COIN
	6 COINS GIVE 1 EXTRA COIN
	7 COINS GIVE 1 EXTRA COIN
	8 COINS GIVE 1 EXTRA COIN
9 COINS GIVE 1 EXTRA COIN	
COIN CHUTE (#1/#2) MULTIPLIER	1 COIN COUNTS AS 1 COINS
	1 COIN COUNTS AS 2 COINS
	1 COIN COUNTS AS 3 COINS
	1 COIN COUNTS AS 4 COINS
	1 COIN COUNTS AS 5 COINS
	1 COIN COUNTS AS 6 COINS
	1 COIN COUNTS AS 7 COINS
	1 COIN COUNTS AS 8 COINS
	1 COIN COUNTS AS 9 COINS



## ○ SEQUENCE SETTING

When SEQUENCE SETTING is selected in either first or second screen, the SEQUENCE SETTING Mode (the third screen) appears.

In this mode, number of credits required for starting game can be set.

```
COIN ASSIGNMENTS
SEQUENCE SETTING

SEQUENCE1 *CREDIT
SEQUENCE2 *CREDIT
SEQUENCE3 *CREDIT
SEQUENCE4 *CREDIT
SEQUENCE5 *CREDIT
SEQUENCE6 *CREDIT
SEQUENCE7 *CREDIT
SEQUENCE8 *CREDIT
> EXIT

[ X X X X X X X X X X X X ]
[ SEGA ENTERPRISES,LTD. ]
DESCRIPTION OF SEQUENCE
SEQ1 ****
SEQ2 ****
SEQ3 ****
SEQ4 ****
SEQ5 ****
SEQ6 ****
SEQ7 ****
SEQ8 ****

SELECT WITH SERVICE BUTTON
AND
PRESS TEST BUTTON
```

Each sequence can be set between 1 ~ 5.  
Select EXIT to return to the first screen.

## H. BOOKKEEPING

This allows such data as operating time/No. of coins inserted/ No. of credits to be checked, etc. This test consists of 2 screens. Pressing SERVICE Button causes screen to be changed. Press TEST Button to return to the MENU screen.

On the first screen, such data as total time, coin, and credit are displayed.

BOOKKEEPING			
TOTAL TIME	55H27M13S		
COIN1	16	SERVICE1	5
COIN2	4	SERVICE2	0
CREDIT	10		
TOTAL COIN	20		
COIN CREDIT	10		
SERVICE CREDIT	5		
TOTAL CREDIT	15		
PRESS SERVICE BUTTON TO ANOTHER PAGE			
PRESS TEST BUTTON TO EXIT			

- Total Time is displayed as " X X H X X M X X S" and no date will be displayed after exceeding 24 hours.
- The displays for number of coin and number of service vary depending on the CABINET TYPE set in SYSTEM ASSIGNMENTS.  
Number of credit displays 1 if COIN CHUTE TYPE is set to COMMON in COIN ASSIGNMENTS. If COIN CHUTE TYPE is set to INDIVIDUAL, the applicable number in CABINET TYPE setting will be displayed.

On the second screen, each sequence displays the frequency of functioning.

BOOKKEEPING			
	PLAYER1	PLAYER2	
SEQ1	1	SEQ1	0
SEQ2	0	SEQ2	1
SEQ3	1	SEQ3	0
SEQ4	0	SEQ4	1
SEQ5	0	SEQ5	0
SEQ6	0	SEQ6	0
SEQ7	0	SEQ7	0
SEQ8	0	SEQ8	0
PRESS SERVICE BUTTON TO ANOTHER PAGE			
PRESS TEST BUTTON TO EXIT			

## I. BACKUP RAM CLEAR

Clears contents of BOOKKEEPING, operating time, coin/credit data, number of games played, etc.

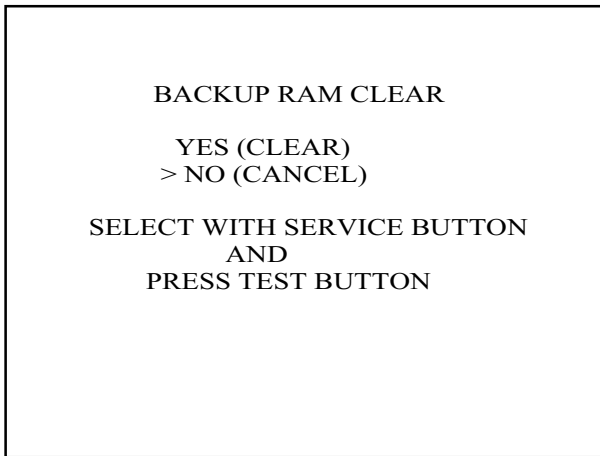

Selecting YES clears the aforementioned data. Select NO and press TEST Button to have the MENU mode return without clearing data.

Note that this does not affect the data of BOOKKEEPING in GAME TEST Mode. To clear the contents of BOOKKEEPING in GAME TEST Mode, enter into GAME TEST Mode and execute BACKUP DATA CLEAR.

## J. ROMBD TEST

In this test, on-ROM-BD ROM check is executed. If GOOD is displayed, it is satisfactory. The IC No., TYPE, BYTE, and WORD refers to the check sum of each unit. Press TEST Button to return to MENU mode.

```

ROMBD TEST
[ X X X X X X X X X X X X ]
[ SEGA ENTERPRISES,LTD.   ]

NO. TYPE RESULT  NO. TYPE RESULT
IC29 **M ----   IC** **M GOOD
IC30 **M ----   IC** **M GOOD
IC** **M GOOD   IC** **M GOOD
IC** **M GOOD   IC** **M GOOD
IC** **M GOOD   IC** **M GOOD
IC** **M GOOD   IC** **M GOOD
IC** **M GOOD   IC** **M GOOD
IC** **M GOOD   IC** **M GOOD
IC** **M GOOD   IC** **M GOOD
IC** **M GOOD   IC** **M GOOD
IC** **M GOOD   IC** **M GOOD
..... ..
..... ..
IC** **M GOOD

PRESS TEST BUTTON TO EXIT

```

In case of above screen, IC 29 and IC 30 do not display GOOD or BAD.

Press SERVICE Button to proceed to the screen the check sum is displayed.

```

ROMBD TEST
[ X X X X X X X X X X X X ]
[ SEGA ENTERPRISES,LTD.   ]

NO. TYPE BYTE WORD NO. TYPE BYTE WORD
IC29 **M **** * IC** **M **** *
IC30 **M **** * IC** **M **** *
IC** **M **** * IC** **M **** *
IC** **M **** * IC** **M **** *
IC** **M **** * IC** **M **** *
IC** **M **** * IC** **M **** *
IC** **M **** * IC** **M **** *
IC** **M **** * IC** **M **** *
IC** **M **** * IC** **M **** *
IC** **M **** * IC** **M **** *
IC** **M **** * IC** **M **** *
..... ..
IC** **M **** *

PRESS TEST BUTTON TO EXIT

```

## K. CLOCK SETTING

YEAR, MONTH, DAY, HOUR, and MINUTE are set for SEGA HIKARU BD.  
Select the desired item with SERVICE Button and press TEST Button to increase the value.  
Bring the arrow to EXIT and press TEST Button to return to MENU Mode.

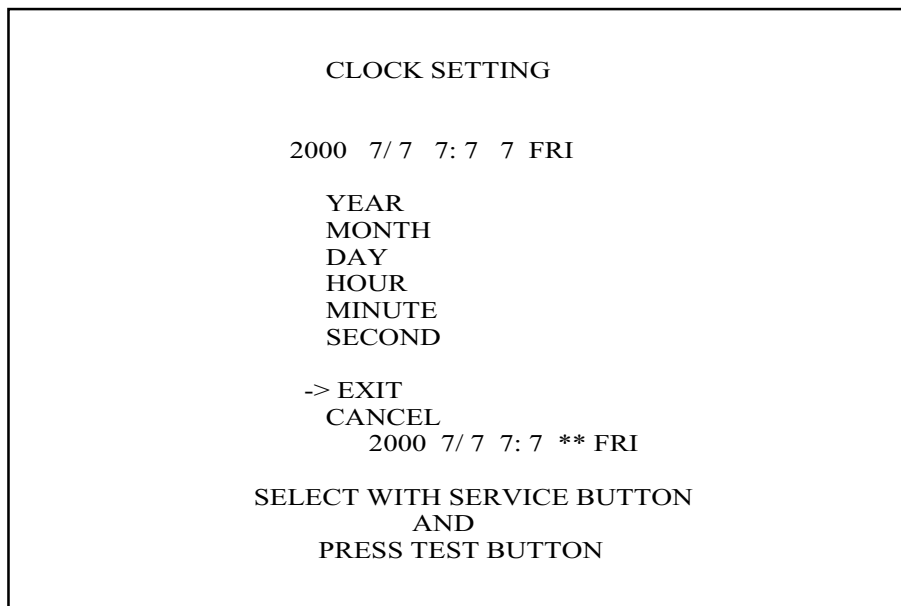

## L. GAME TEST MODE

Enters the TEST Mode of the game connected to SEGA HIKARU BD. The TEST Mode includes INPUT Test, GAME ASSIGNMENTS such as game difficulty, etc. Refer to 9-3 for details.

## 9 - 3 GAME TEST MODE

### A. GAME MENU

According to the COMMUNICATION MODE setting in the SYSTEM ASSIGNMENTS screen in the SYSTEM TEST MODE, the display items in the GAME TEST MENU vary.

In the case as the COMMUNICATION MODE is set to other than RELAY:

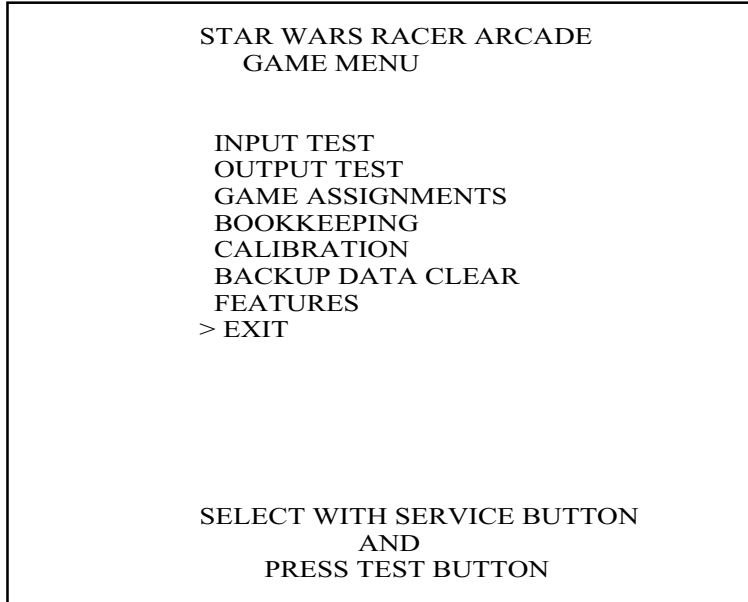

When the COMMUNICATION MODE is set to RELAY:

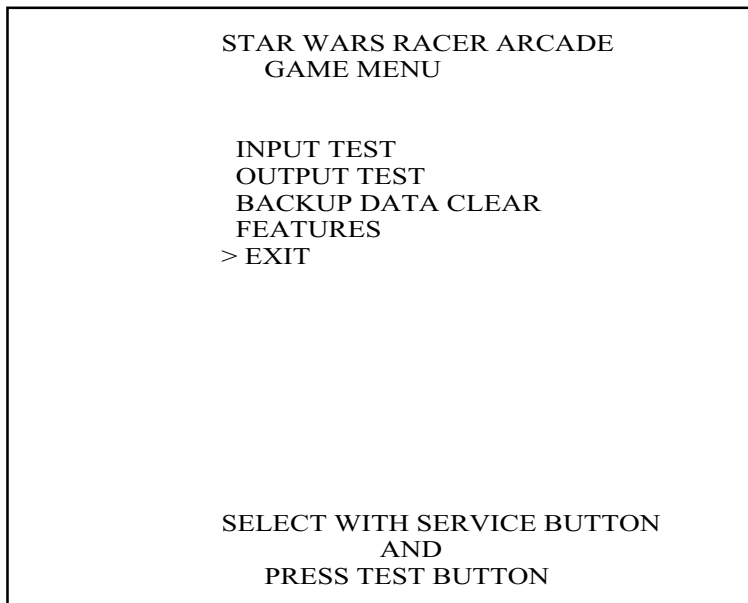

Bring the arrow (>) to the desired item and press the TEST button. Hereafter the same applies to the items that display an arrow. The SELECT button and the START button on the CONTROL PANEL function the same. Select the EXIT and press the TEST button to return to the SYSTEM TEST MENU screen.

## B. INPUT TEST

INPUT TEST	
BOOST	OFF
BRAKE	OFF
LEFT BUTTON	OFF
RIGHT BUTTON	OFF
START	OFF
SERVICE	OFF
TEST	OFF
LEFT LEVER	**
RIGHT LEVER	**
PRESS TEST AND SERVICE BUTTON TO EXIT	

Performs test for the input units. Periodically perform test in this screen. While each button on the cabinet is pressed down, if the display goes ON, operation is satisfactory. The value for the Lever changes according to operation of the LEVER. Press the SERVICE button and the TEST button simultaneously to return to the GAME TEST MENU screen.

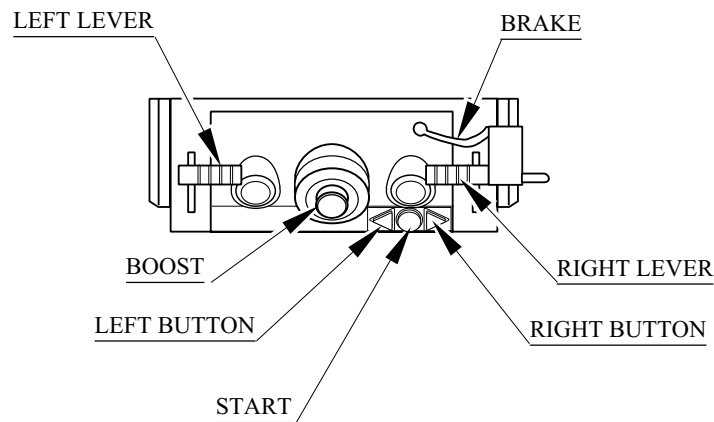

### RECOMMENDED VOLUME VALUE

The range of the recommend Volume value for the Lever is within 2D ~ C1. If the value does not fall into the range, or if the Lever V.R. value movements are irregular, adjust the V.R. in the following procedure (10-2).

The above range shows the maximum allowable values. From the viewpoint of the design, the moving range of the Volume is approximately 70H, therefore when the minimum value is 2D, the maximum value should be  $\pm 9D$ .

### C. OUTPUT TEST

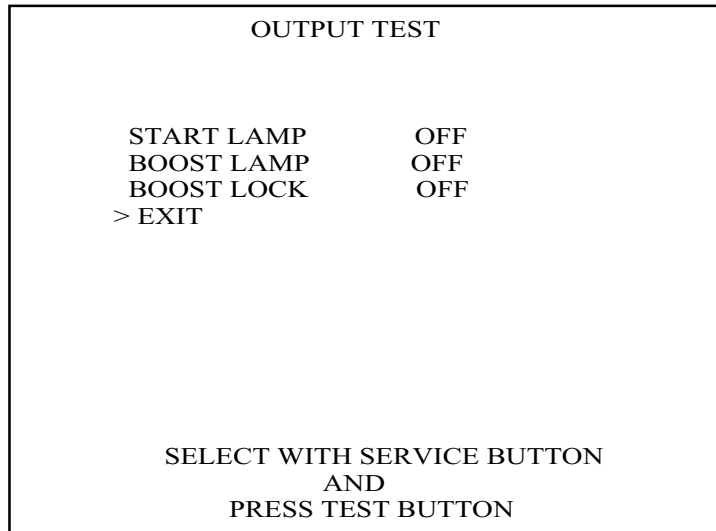

Operation status of each output unit can be checked. Select an item with the SERVICE button and press the TEST button. Each time you press the TEST button, ON/OFF display alters. If the lamps for the START and the BOOST buttons go on when ON is displayed, operation is satisfactory. Change the BOOST LOCK to ON with the BOOST button pressed down. If the button is locked in the state of being pressed down, operation is satisfactory. If the CONTROL PANEL is set to STANDARD in D. GAME ASSIGNMENTS, the BOOST LOCK is not displayed on the screen.

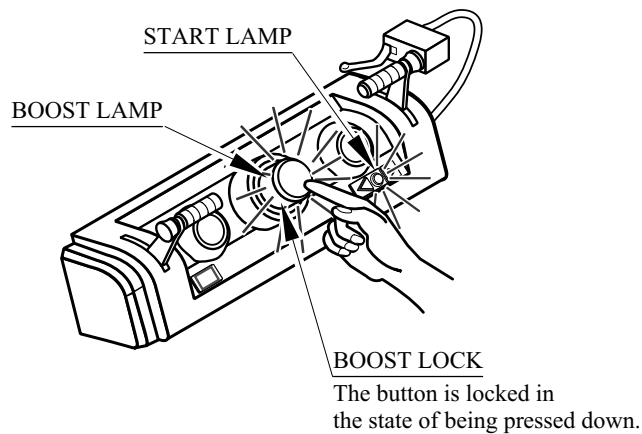



## D. GAME ASSIGNMENTS

According to COMMUNICATION MODE setting in the SYSTEM ASSIGNMENT screen in the SYSTEM TEST MODE, the display items in the GAME ASSIGNMENTS vary.

In the case the cabinet is set to MASTER.

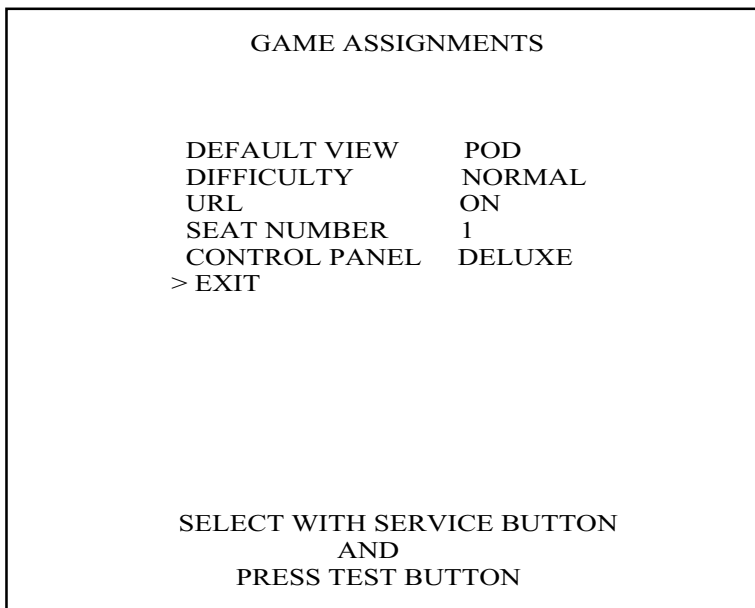

In the case the cabinet is set to SLAVE.

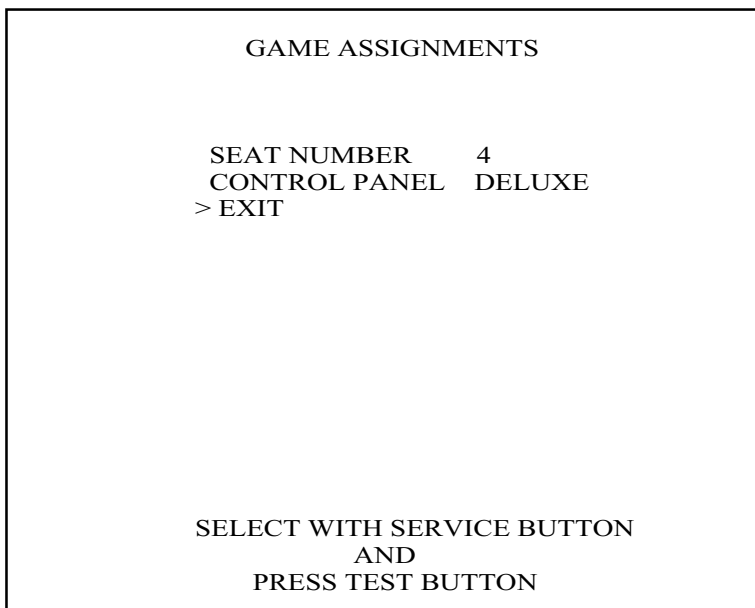

In the case the cabinet is set to NO LINK.

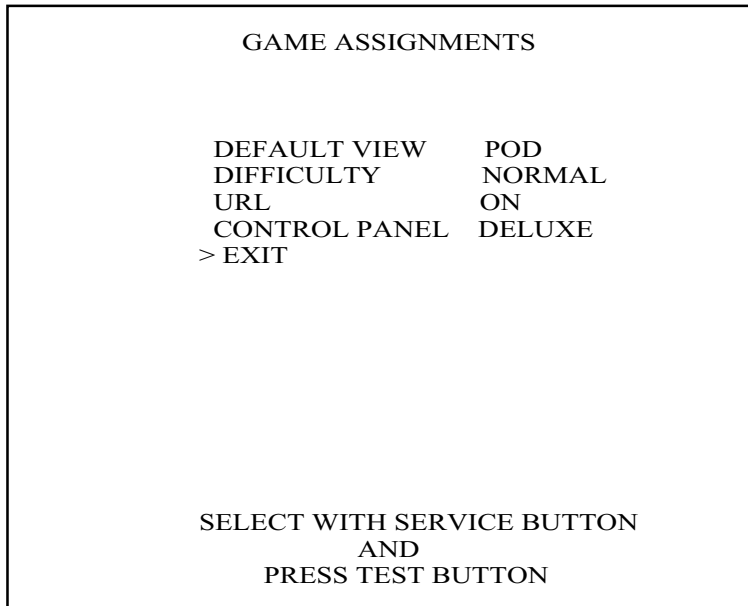

The in-game default view can be set in the DEFAULT VIEW. Select either POD (Subjective view) or REAR (Objective view from the rear).

The game difficulty can be set in the DIFFICULTY. Select from among VERY EASY/ EASY/ NORMAL/ HARD/ VERY HARD. The higher the difficulty, the lesser the points you get when passing through the checkpoints.

When the URL is set to ON, the official Home Page address for the game is displayed during the ADVERTISE mode.

The ID number for each machine for communication play can be set in the SEAT NUMBER. Select the ID number from 1 to 4 and apply to each machine linked for communication play. If the same numbers are applied to the 2 or more machines, the monitor displays "CONFLICTING SEAT NUMBER" and game cannot start.

In CONTROL PANEL, settings for the solenoid control for the lock mechanism inside the Control Panel and the error display can be performed.

Select either DELUXE or STANDARD. In the case of selecting DELUXE, when the BOOST button is pressed, the button is locked as is pressed down due to activation of the solenoid. An error is displayed on the screen if the BOOST button or the lock mechanism malfunctions (Sec.15).

In the case of selecting STANDARD, the solenoid control and an error display are not performed.

## E. BOOKKEEPING

The BOOKKEEPING displays the data of gameplay time, the frequencies of the vehicles and the course selection, etc. in a total of 2 pages.

BOOKKEEPING 1/2	
NUMBER OF GAMES	0
PLAY TIME	0D 0H 0M 0S
AVERAGE PLAY TIME	0H 0M 0S
LONGEST PLAY TIME	0H 0M 0S
SHORTEST PLAY TIME	0H 0M 0S
TIME HISTOGRAM	
0M00S ~ 0M29S	0
0M30S ~ 0M59S	0
1M00S ~ 1M29S	0
1M30S ~ 1M59S	0
2M00S ~ 2M29S	0
2M30S ~ 2M59S	0
3M00S ~ 3M29S	0
3M30S ~ 3M59S	0
4M00S ~ 4M29S	0
4M30S ~ 4M59S	0
OVER 5M00S	0
PRESS TEST BUTTON TO CONTINUE	

- **NUMBER OF GAMES:**  
Total number of plays.
- **PLAY TIME:**  
Total play time.
- **TIME HISTOGRAM:**  
By-playtime play frequency bookkeeping is displayed in increments of 30 seconds from 0M00S to 5M00s.

Press the TEST button to proceed to the next page (2/2).

BOOKKEEPING 2/2		
TOTAL NUMBER OF GAMES 637 (391F:246R)		
POD SELECTED		
ANAKIN	384	(280F:104R)
SEBULBA	195	( 85F:110R)
QUADINAROS	40	( 18F:22R )
GASGANO	18	( 8F:10R )
COURSE SELECTED		
EASY	382	(269F:113R)
NORMAL	75	( 49F:26R )
HARD	48	( 33F:15R )
EXPERT	132	( 40F:92R )
PRESS TEST BUTTON TO EXIT		

In the parentheses next to each item, the F refers to "FINISH" and the R refers to "RETIRE" (for your reference when setting the game difficulty).

In the POD SELECTED screen, only ANAKIN and SEBULBA are displayed at the time of shipment. Once each of the other 2 vehicles becomes usable by fulfilling the certain requirements, such vehicle will be added to the screen one by one.

Press the TEST button while the page 2 is displayed to return to the GAME MENU screen.

## F. CALIBRATION TEST

The volume values for the Throttle Levers left & right can be calibrated. When operation of the Lever is not satisfactory, adjust the volume value in this screen.

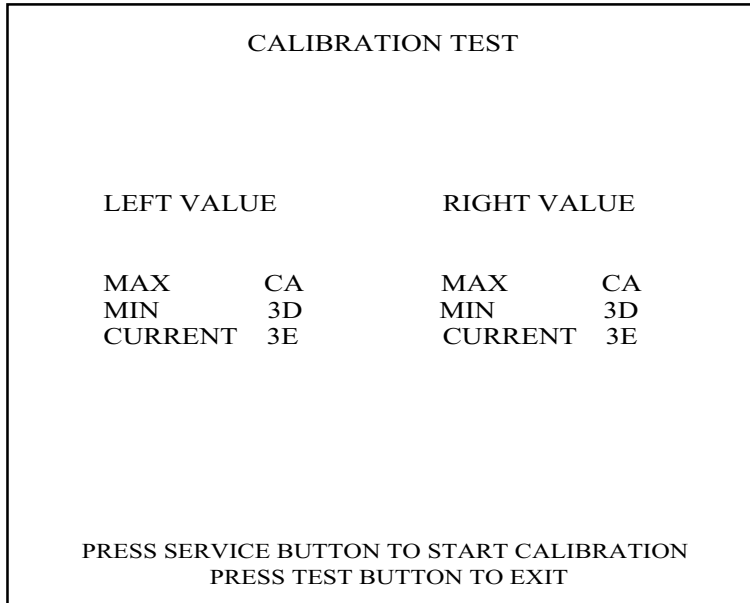

When performing calibration, first press the SERVICE button. The message in the lower screen changes as shown.

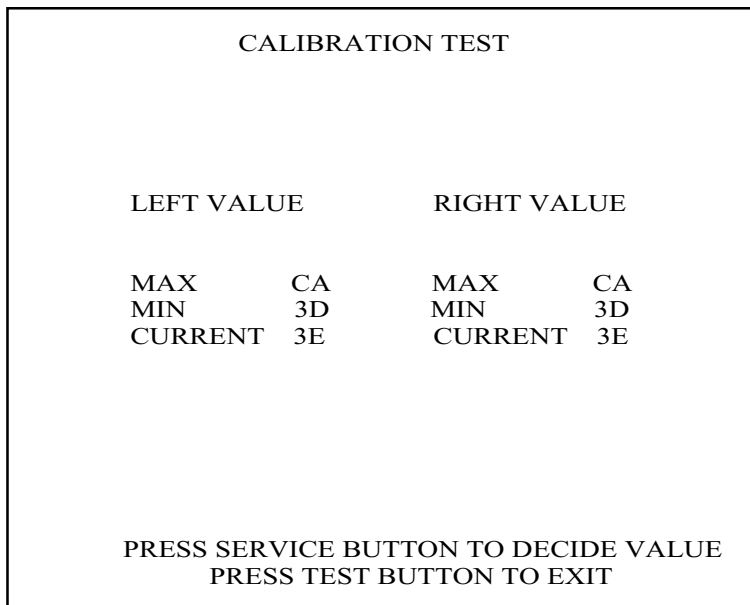

While the above screen is displayed, incline the Throttle Levers left & right lightly to the front and the rear ends. Each of the MAX/ MIN/ CURRENT analog input values for both the left and the right Levers are displayed. Press the TEST button to return to the GAME MENU screen.

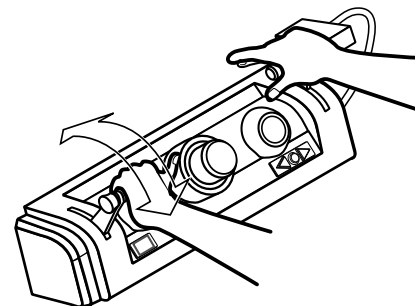

## G. BACKUP DATA CLEAR

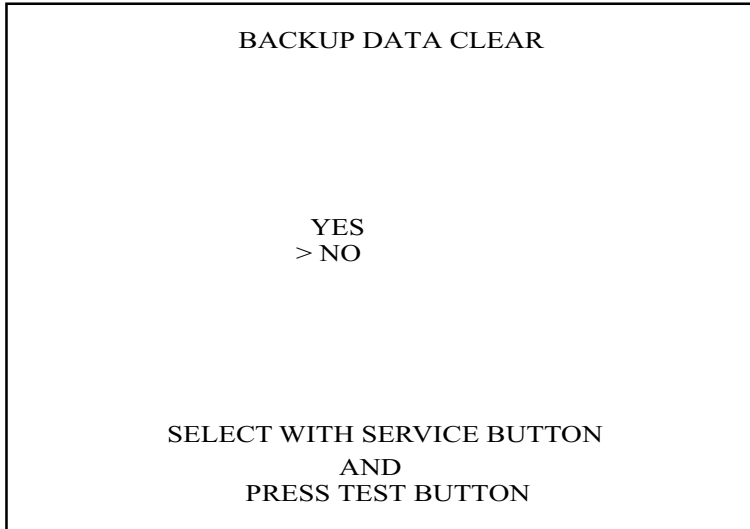

Clears the contents of the BOOKKEEPING. Bring the arrow to "YES" with the SERVICE button and press the TEST button. "COMPLETED" is displayed after the data have been cleared. Bring the arrow to "NO" and press the TEST button when not clearing. Unlike the "BACKUP DATA CLEAR" in the SYSTEM TEST MENU, the play frequency data are cleared mainly in this mode.

(The setting values in the GAME ASSIGNMENTS, the BOOKKEEPING data in the GAME MENU, and the high scores.)

Since the BACKUP DATA CLEAR clears the play-frequency data, executing this mode before meeting the requirements delays appearance of the hidden vehicles.

## H. FEATURES

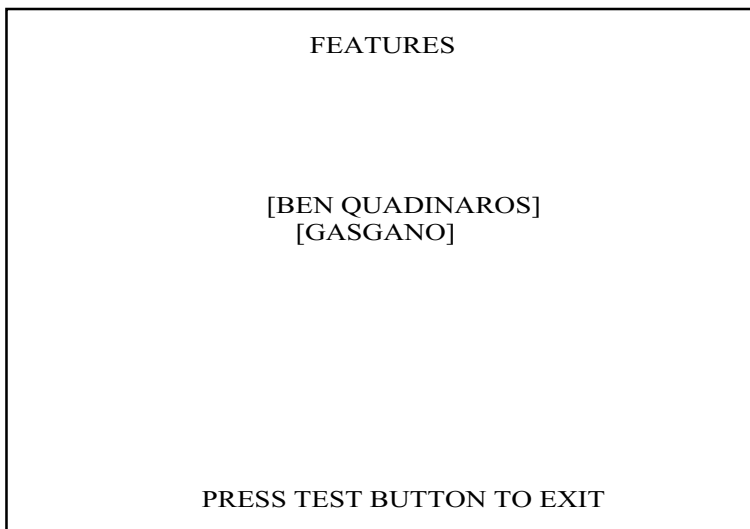

In the FEATURES, the name of hidden vehicles that have been made appeared by fulfilling the certain requirements can be checked. If the hidden vehicles have not been made appeared, nothing but "DISABLED" is displayed. There are 2 kinds of vehicles hidden, and the requirements to make the vehicle appear differ one by one. Press the TEST button to return to the GAME MENU screen.

## 10. CONTROL PANEL



WARNING!

- Before starting to work, ensure that the Power SW is OFF. Failure to observe this can cause electric shock or short circuit.
- Use care so as not to damage wirings. Damaged wiring can cause electric shock or short circuit.
- Do not touch undesiganted places. Touching places not designated can cause electric shock or short circuit.
- This work should be performed by the Location's Maintenance Man or Serviceman. Performing work by non-technical personnel can cause electric shock hazard.
- Do not perform work other than those specified in this Manual in order to prevent accidents during performing work and operation after performing work. Performing work not specified in this Manual may require special training for this product. If performing work other than those stated in this manual is required for repair, contact the offices herein stated in this manual or where you purchased the product from and ask for repair or inquire how to repair.



CAUTION!

- Use care when handling the parts inside the control panel. Be careful so as not to cause damaging, missing, or deforming the parts. Damaging small portion of a part can cause malfunctioning.
- When securing the plastic-made parts, do not excessively fasten screws and nuts. Failure to observe this may damage the parts and cause injury due to fragments resulting from damage.

In this product, the input units are mounted on the control panel. The input units include the Levers on the control panel left and right, the Brake Lever (the right-hand side), the BOOST button (the center), the START button (the lower right), and the SELECLT buttons beside the START button on the control panel. Be sure to check reaction of each input unit at a monthly inspection. If the operability is poor and performing CALIBRATION in the test mode does not improve the situation, the causes may be malfunctioning of the input unit in the control panel.

## 10 - 1 REMOVING THE CONTROL PANEL COVER

In order to check the control panel inside, first remove the control panel cover.

- ① Turn power off.
- ② Remove the GRIP from the Lever left. Take out a screw for each to remove the GRIP, the GRIP END, and the GRIP PIN from the Lever.

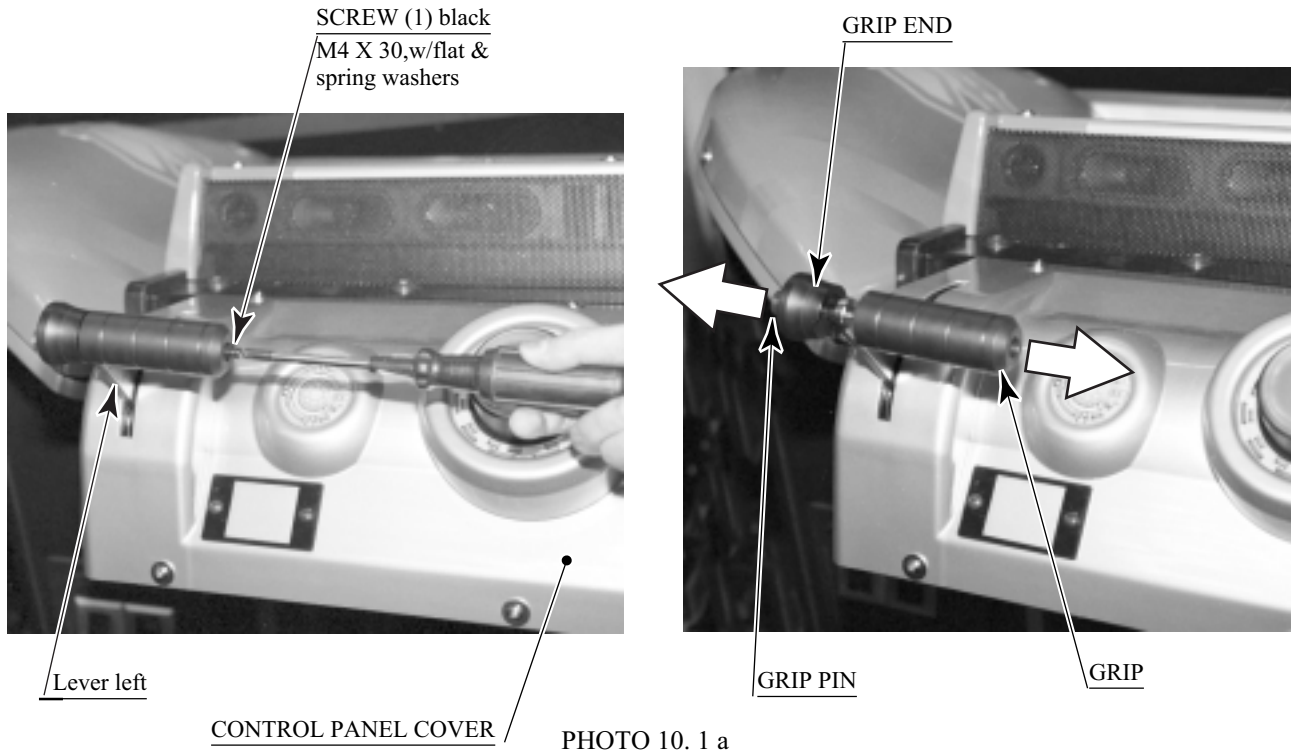

- ③ Remove the GRIP and the ASSY BRAKE from the Lever right. Take out a screw for each to remove the GRIP, the GRIP END, and the ASSY BRAKE from the Lever. To avoid damaging wiring, do not allow the ASSY BRAKE to come down.

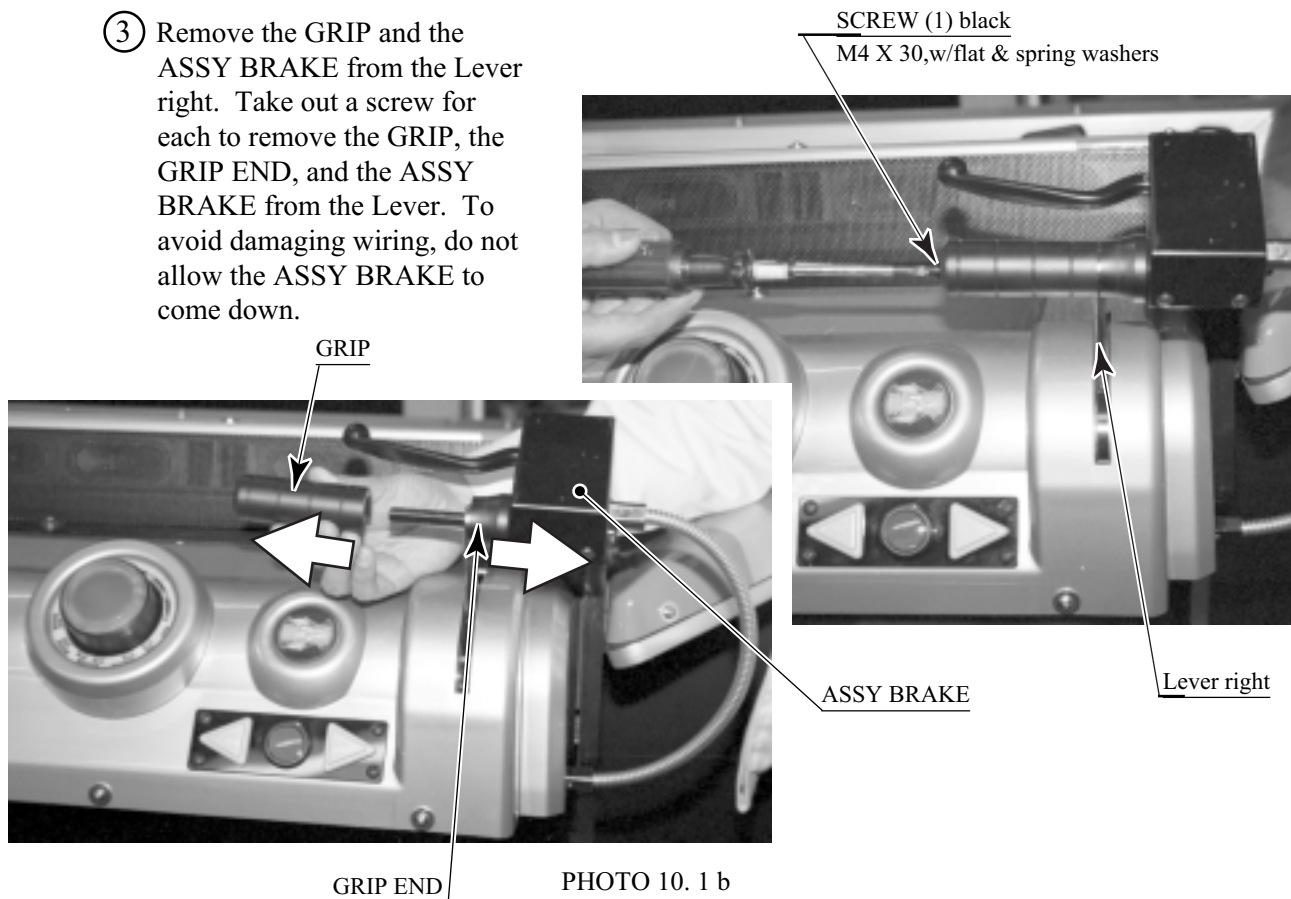

- ④ Take out the 4 truss screws securing the ASSY START SW. Handle with care so as not to damage the wiring inside the unit.
- ⑤ By using care, pull out the WIRE CONNECTOR from the ASSY START SW.

ASSY START SW

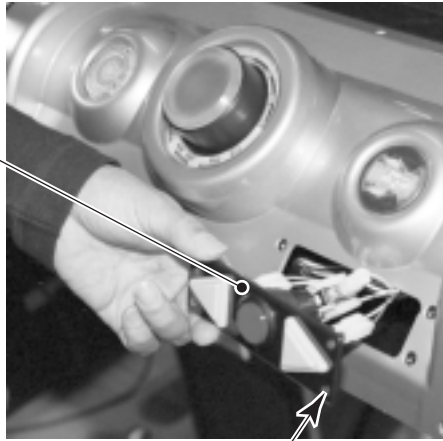

TRUSS SCREW (4) black  
M4 X 12

PHOTO 10. 1 c



Disconnect the connector.

- ⑥ Take out a total of 11 screws securing the CONTROL PANEL COVER.
- ⑦ Remove the CONTROL PANEL COVER from the cabinet. To reinstall the CONTROL PANEL COVER, follow the above procedure in a reverse order. Don't mistake the right side for the left (and vice versa) when reinstalling the ASSY START SW. At this time make sure the terminal on the START button is located in the upper right.

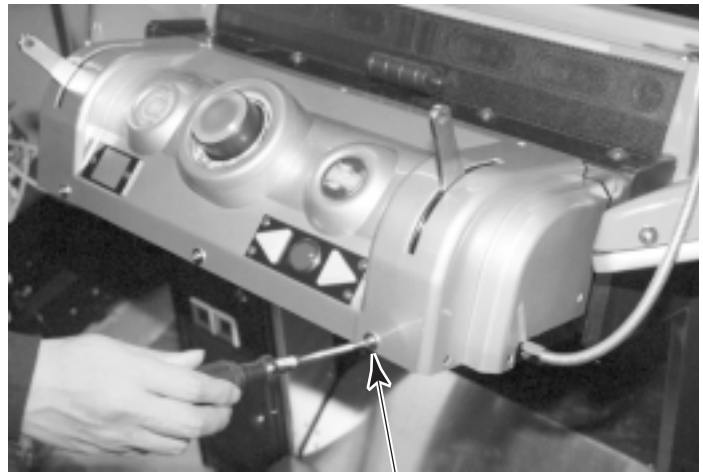

PHOTO 10. 1 d

TRUSS SCREW (11 in total)  
M4 X 8, flat washer used,  
chrome

The START button's terminals.



PHOTO 10. 1 f



PHOTO 10. 1 e



## 10 - 2 VOLUME ADJUSTMENT/REPLACEMENT

In case the operability of the Lever left and right is poor and performing CALIBRATION in the test mode does not improve the situation, the causes may be the failure of the Volume Gear's engagement in the ASSY LEVER MECHA inside the control panel and or Volume malfunctioning. Follow the following procedure to perform Volume adjustment or replacement. Since work is performed inside the energized cabinet, be very careful so as not to touch undesignated places.

### ADJUSTMENT

- ① Turn off power and remove the CONTROL PANEL COVER (10-1).
- ② Loosen the 2 screws securing the VR BRACKET in the ASSY LEVER MECHA to push the gear out of mesh.
- ③ With the Lever being at the centering position, bring the gear into mesh so that the status of the volume's shaft is as shown in the Fig. (FIG.10.2)

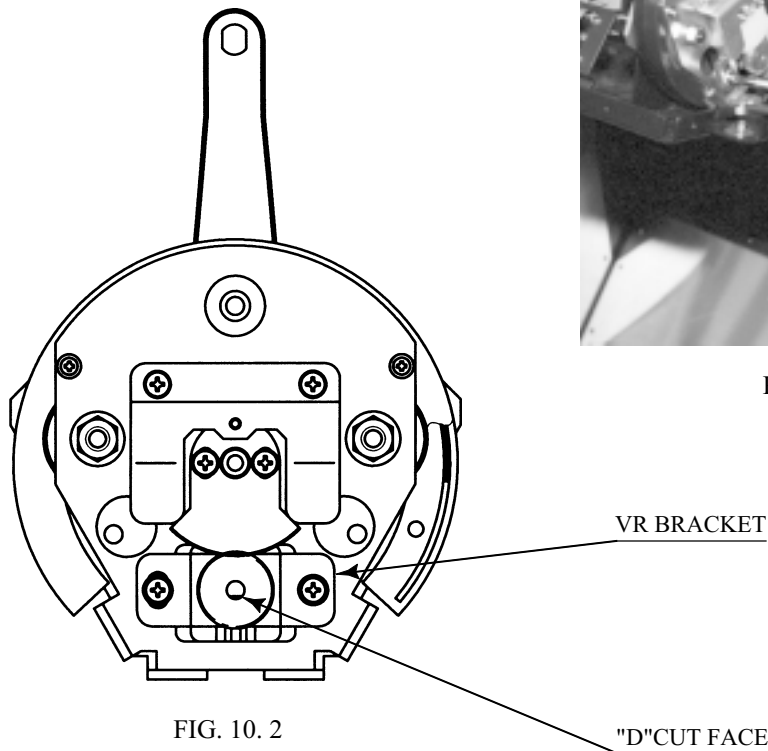

FIG. 10. 2

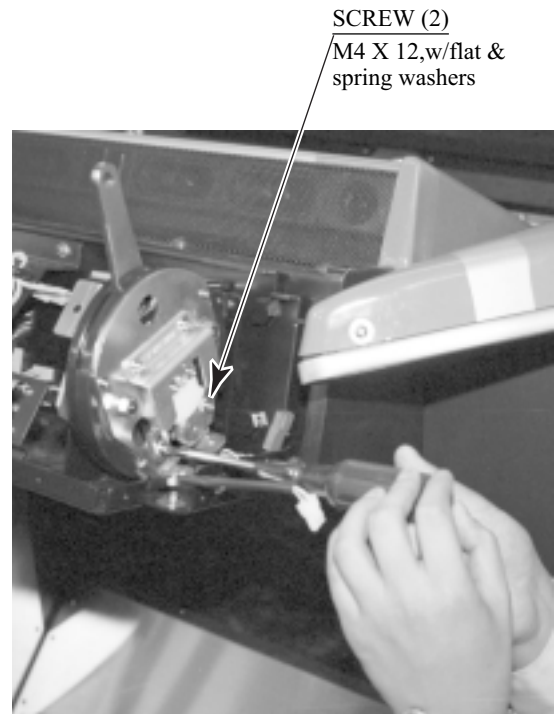

PHOTO 10. 2 a

- ④ Fasten the screws securing the VR BRACKET.
- ⑤ Turn power on and perform volume setting in the CALIBRATION in the test mode. (9-3)
- ⑥ During the INPUT TEST in the test mode, check to see if the volume value varies smoothly in accordance with operation of the Lever. (9-3)
- ⑦ Turn off power.
- ⑧ Install the CONTROL PANEL COVER to change back to the former state.

## REPLACEMENT

If the Volume is in a status as per FIG.10.2, moving the Lever fully forward and backward does not damage parts, as the value does not exceed the Volume's movable range.

- ① Turn off power and remove the CONTROL PANEL COVER (10-1).
- ② Disconnect the connector from the VOLUME to be replaced.
- ③ Take out the 2 screws securing the VR BRACKET in the ASSY LEVER MECHA to remove the VR BRACKET with the GEAR and the VOLUME mounted on it.

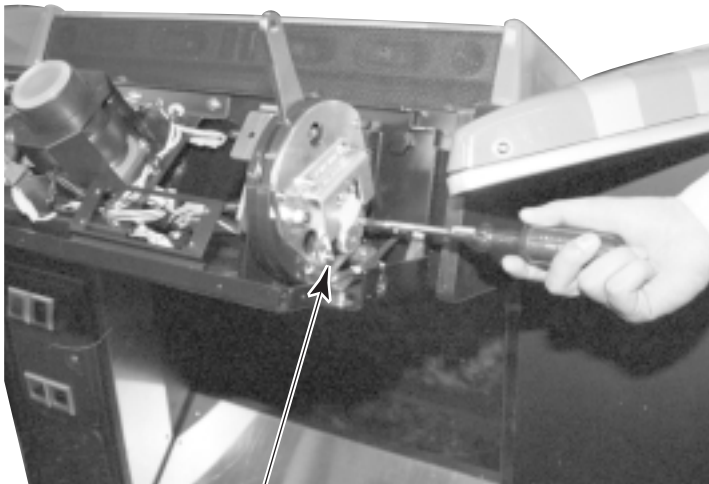

SCREW (2)  
M4 X 12,w/flat & spring washers

PHOTO 10. 2 c



Disconnect the connector.

PHOTO 10. 2 b

- ④ Remove the GEAR and the VOLUME from the VR BRACKET and replace the VOLUME.

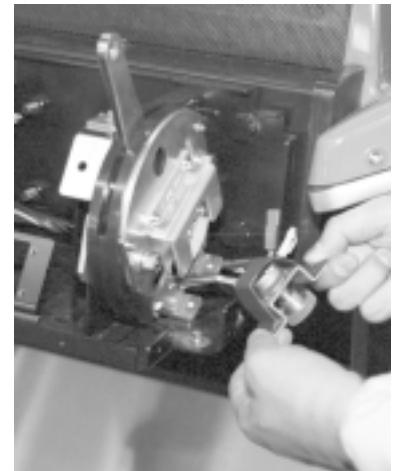

PHOTO 10. 2 d

- ⑤ With the LEVER being at the centering position, bring the gear into mesh so that the status of the volume's shaft is as shown in the Fig. (FIG.10.2)
- ⑥ Fasten the 2 screws securing the VR BRACKET.
- ⑦ Turn power on and perform volume setting in the CALIBRATION in the test mode.
- ⑧ During the INPUT TEST in the test mode, check to see if the volume value varies smoothly in accordance with operation of the Lever. (9-3)
- ⑨ Turn off power.
- ⑩ Install the CONTROL PANEL COVER to change back to the former state.

## 10 - 3 GREASING



CAUTION!

Do not touch the solenoid. The solenoid can be very hot.



IMPORTANT

- Be sure to use the designated grease. Using undesiged grease can cause parts damage.
- Do not apply greasing to undesiged places. Failure to observe this can cause malfunctioning or quality deterioration of parts.
- The period for greasing specified herein is a standard. Apply greasing to the specified portions as occasion arises.

Once every 3 months apply greasing to the volume mesh portion in the ASSY MECHA LEVER and the ASSY BRAKE spring. For spray greasing, use GREASE MATE (PART NO. 090-0066). Apply greasing to the BOOST button MECHA portion semiannually. Use GREASE 248 (PART NO.090-0070) for the portion. If the specified greasing is not obtainable, use greasing for the cold-proof, heat-resisting plastic instead.

### APPLY GREASING TO THE ASSY MECHA LEVER

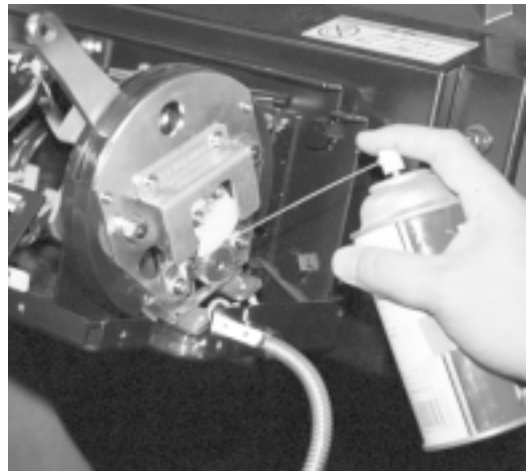

PHOTO 10. 3 a VOLUME GEAR MESH PORTION

### APPLY GREASING TO THE ASSY BRAKE

Insert the spray-greasing nozzle into the square hole of the ASSY BRAKE LEVER to apply greasing to the spring portion.

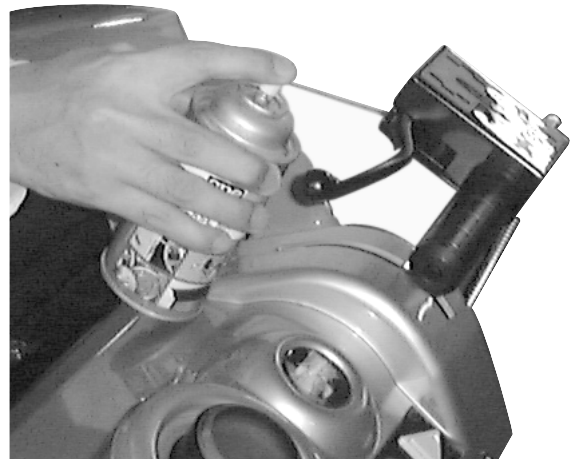

PHOTO 10. 3 b SPRING PORTION

APPLY GREASING TO THE BOOST BUTTON

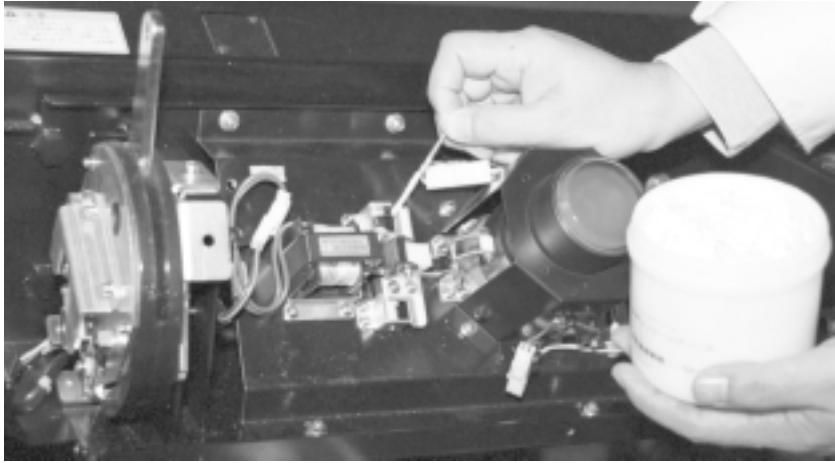

PHOTO 10.3 c

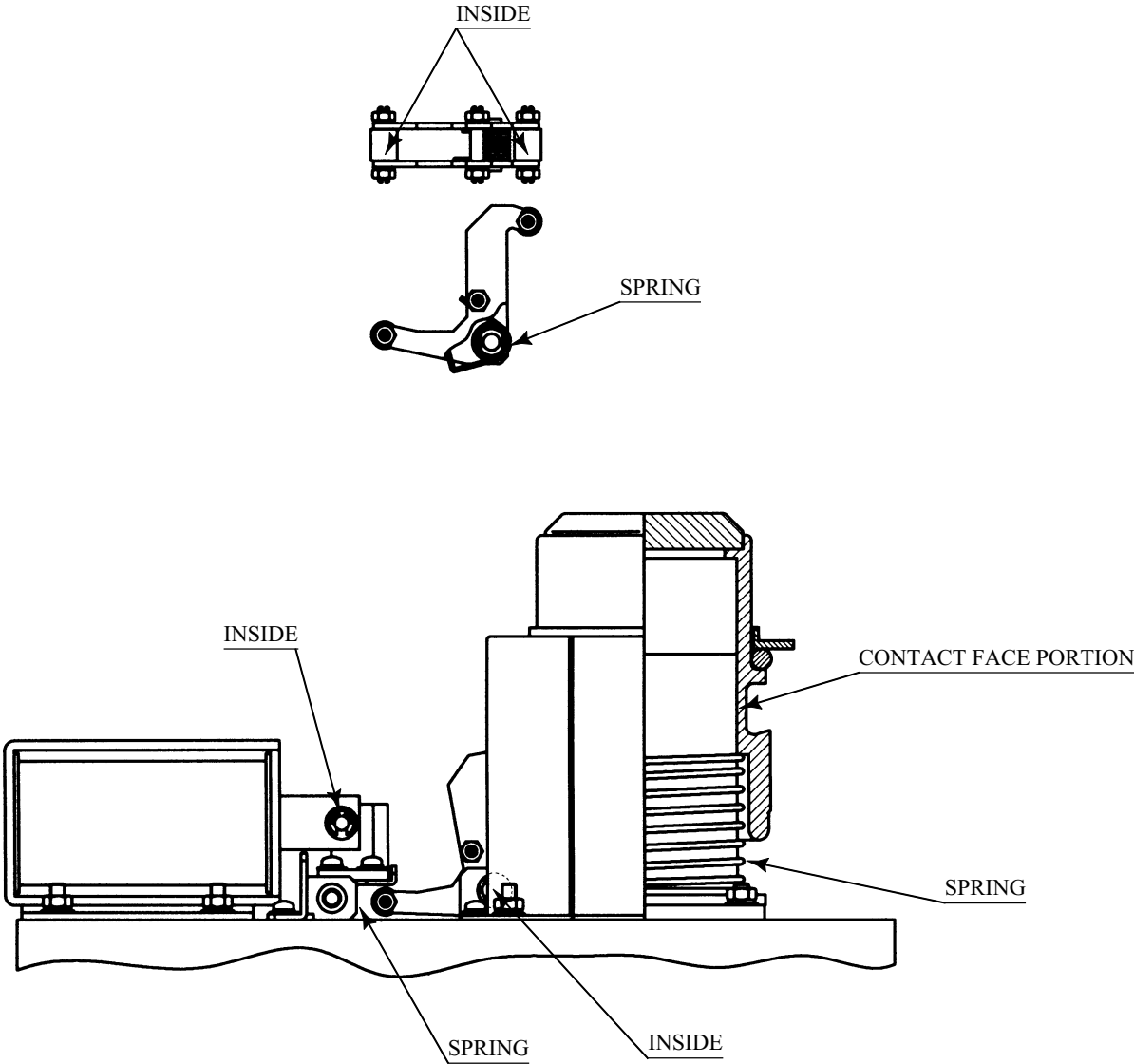

FIG. 10.3

# 11. COIN SELECTOR

## HANDLING THE COIN JAM

If the coin is not rejected when the REJECT button is pressed, open the coin chute door and open the selector gate. After removing the jammed coin, put a normal coin in and check to see that the selector correctly functions.

## CLEANING THE COIN SELECTOR



- Remove and clean smears by using a soft cloth dipped in water or diluted chemical detergent and then squeezed dry.
- Never apply machine oil, etc. to the Coin Selector.
- After cleaning the Coin Selector, insert a regular coin in the normal working status and ensure that the Selector correctly functions.

The coin selector should be cleaned once every 3 months. When cleaning, follow the procedure below:

- ① Turn the power for the machine OFF. Open the coin chute door.
- ② Open the gate and dust off by using a soft brush (made of wool, etc.).
- ③ Remove and clean smears by using a soft cloth dipped in water or diluted chemical detergent and then squeezed dry.
- ④ Remove the CRADLE.  
When removing the retaining ring (E ring), be very careful so as not to bend the rotary shaft.
- ⑤ Remove stain from the rotary shaft and shaft receiving portions by wiping off with a soft cloth, etc.
- ⑥ After wiping off as per ⑤ above, further apply a dry cloth, etc. to cause the coin selector to dry completely.

## COIN INSERTION TEST

Once every month, when performing the Coin SW Test, simultaneously check the following:

- Does the Coin Meter count satisfactorily?
- Does the coin drop into the Cashbox correctly?
- Is the coin rejected when inserted while keeping the Reject Button pressed down?

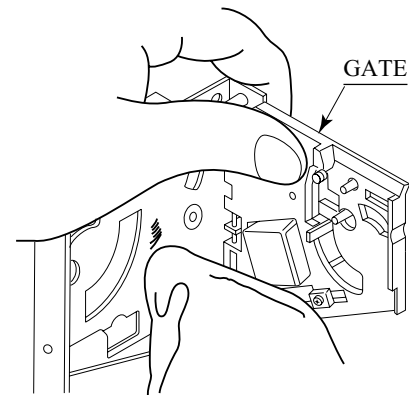

FIG. 11 a

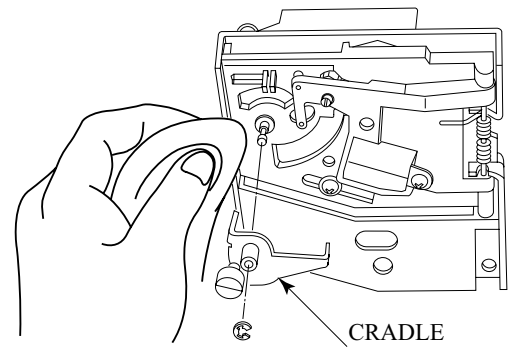

FIG. 11 b

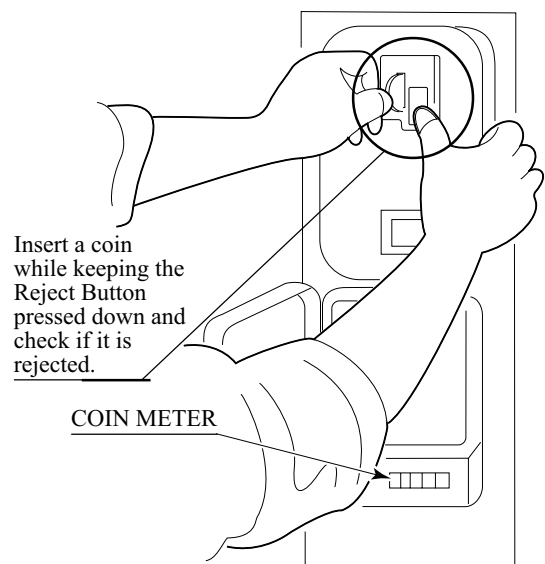
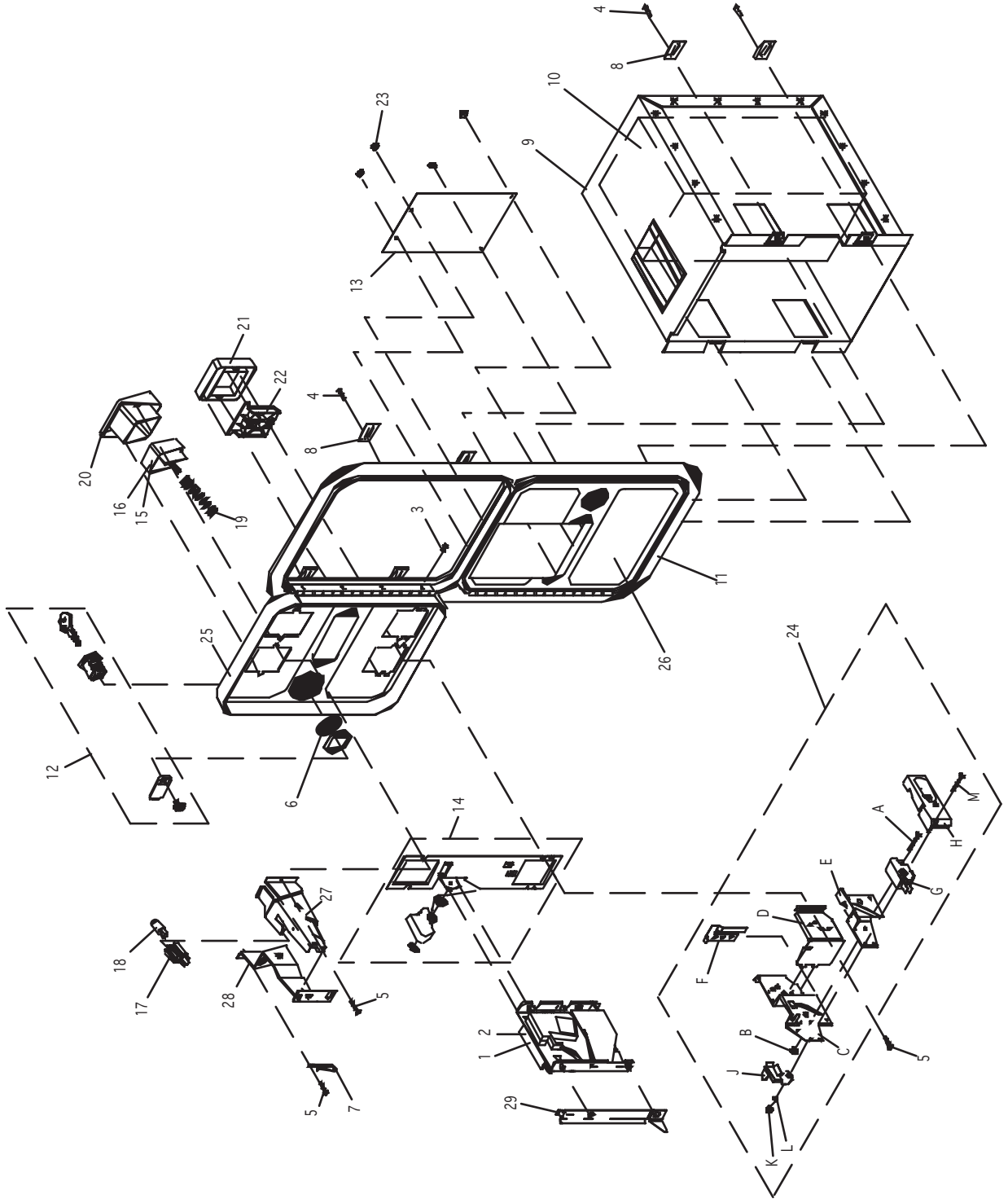

FIG. 11 c

WELLS-GARDNER  
ELECTRONICS CORPORATION  
2701 N. KILDARE CHICAGO, IL 60639  
1-800-336-6630  
WWW.WGEC.COM

WGD15-2110-01  
OVER/UNDER MINI DOOR  
2 ENTRIES WITH BILL  
VALIDATOR BOTTOM DOOR  
& SPECIAL ENCLOSURE



#	W.G. PART #	DESCRIPTION
1	812-4150-011	S-7 US 25c COIN MECH LEFT
2	812-4050-011	S-10 US \$1 COIN MECH RIGHT
3	890-1002-00	HINGE SCREW
4	890-1003-00	CLAMP SCREW
5	890-1017-00	SCREW TRILOBULAR
6	890-1019-00	WASHER INTERNAL TOOTH 3/4"
7	890-1300-00	KEYHOOK
8	891-0514-00	CLAMP LK 5/8" CABINET
9	025X3711-001	ENCLOSURE W/CHUTE
10	025X3712-001	METAL CASHBOX
11	891-0509-162	DOUBLE FRAME
12	891-0547-00	LOCK SINGLE BIT
13	891-0100-4016	COVER PLATE
14	891-1008-107	BASE PLATE ASSEMBLY
15	891-1113-03	E/R BUTTON US 4x25c/\$1 LEFT
16	891-1113-011	E/R BUTTON US \$1 COIN RIGHT
17	891-1117-00	LAMPHOLDER
18	891-1118-00	LAMP WEDGE BASE 6 VOLT
19	891-1121-00	SPRING, E/R BUTTON
20	891-1311-16	BUTTON BEZEL, NYLON
21	891-1312-16	REJECT BEZEL, NYLON
22	891-1109-16	REJECT FLAP
23	020X1877-005	NUTKFS #8-32 X 5/16 HEX
24	891-2216-16	MICROSWITCH ASSEMBLY
24A	890-1007-00	SCREW FLAT HEAD M/S
24B	890-1206-02	KEP NUT
24C	891-1105-01	REJECT CUP SIDE PLATE
24D	891-1106-00	REJECT CUP BASE PLATE
24E	891-1107-00	BRACKET, MICROSWITCH
24F	891-1110-00	ADJUSTER, COIN
24G	891-1116-16	MICROSWITCH, BLACK - MED.
24H	891-1125-00	COVER, PLASTIC
24J	892-1002-07	CLIP, SNAP-ON
24K	892-1002-08	ELASTIC SNAP NUT
24L	892-1002-09	SLEEVE, SNAP-ON
24M	892-1002-11	SCREW, PAN HEAD
25	891-0604-16	MINI DOOR 2 ENTRIES
26	891-0614-16	MINI DOOR W/DBV C/O
27	892-1002-01	BRACKET, LAMP SIDE
28	892-1002-021	BRACKET, COVERSIDE
29	892-1002-10	BRACKET, HOLD DOWN



## OPTIONAL DOLLAR BILL ACCEPTOR

● THE COIN DOOR ASSEMBLY USED ON **STAR WARS RACER ARCADE DX TYPE** COMES EQUIPPED TO ACCEPT A DOLLAR BILL ACCEPTOR. ALL NEEDED WIRING CONNECTIONS ARE CONVIENENTLY LOCATED INSIDE THE GAME FOR THIS APPLICATION.

● THE COIN DOOR CAN ACCCOMMODATE THE FOLLOWING VALIDATOR(S):

FORWARD-MOST  
HOLE POSITION

Mars 2000 series

\*\*42-1155-00            MARS VALIDATOR \$1, 2, 5 300 CAP

The frame and cashbox enclosure on this coindoor has been modified to accomodate a Mars 2000 series upstacker. A 2000 series stacker can be added by simply removing the cut-out plate. This one entry door can be ordered through Happ Controls or one of Happ Controls authorized distributors. The part number is 40-6000-10EX. The Mars stacker can be obtained through an auztherized Mars distributor.

Note: Your game may have either Happ Controls Coin Door Assembly or the Wells Gardner Coin Door Assembly (not shown).

\*\*Happ part number

Security Locking Bar/Bracket Set Part No.# 999-0966

Modified Cash Box (For use when DBA installed)  
Part No. # 999-1106

Plastic Cash Box - Full Size Part No. # 999-1177



## 12. PROJECTOR



CAUTION!

Since the Projector has been adjusted at the time of shipment, avoid making further adjustments without good reason.



IMPORTANT

The Projector is subject to color deviation due to Convergence deviation caused by the geomagnetism at the installation location and peripheral magnetic field. After the installation of machine, and before commencing operation, check for Convergence deviation and if deviated, make adjustments.

Projector adjustments are stored. Due to distortion or color deviation in the TEST mode, if an adjustment is necessary, use the Remote Control to make adjustments.

### 12 - 1 CLEANING THE SCREEN



CAUTION!

Since the Projector screen is susceptible to damage, pay careful attention to its handling. When cleaning, refrain from using water or volatile chemicals.

When the screen surface becomes dirty with dust, etc., clean it by using a soft cloth such as gauze. When water, and volatile chemicals such as benzine, thinner, etc., spill on the screen surface, it may be subject to damage, therefore, do not use them. Also, since the surfaces are susceptible to damage, refrain from rubbing them with a hard material or using a duster.

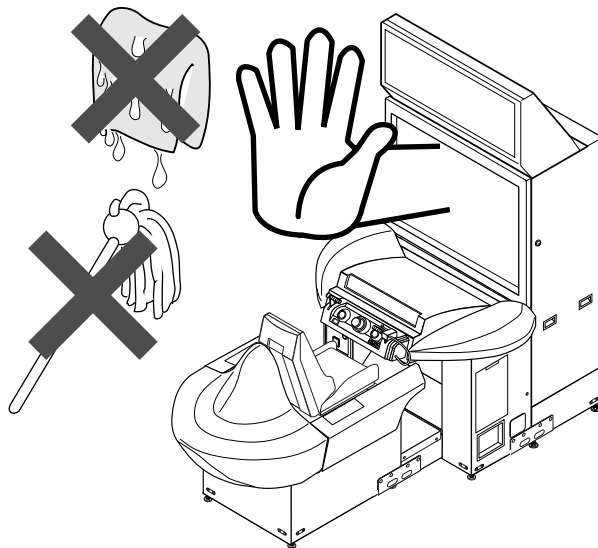

FIG. 12. 1

## 12 - 2 ADJUSTMENT OF PROJECTOR

### SETTING THE INTERFACE



In this product, set to INPUT LEVEL: 0.7V and IMPEDANCE: 75Ω. Failure to observe this can cause CRT membrane to burn or Shutdown device to function resulting in power off.

The Projector's Connector Panel contains the Interface setting SW.

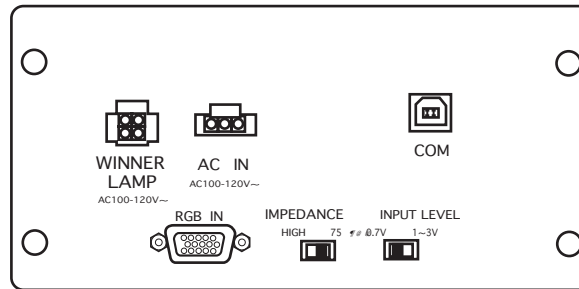

### REMOTE CONTROL BUTTONS

When adjusting the Projector, direct the Remote Control's light emitting portion towards the Projector Screen.

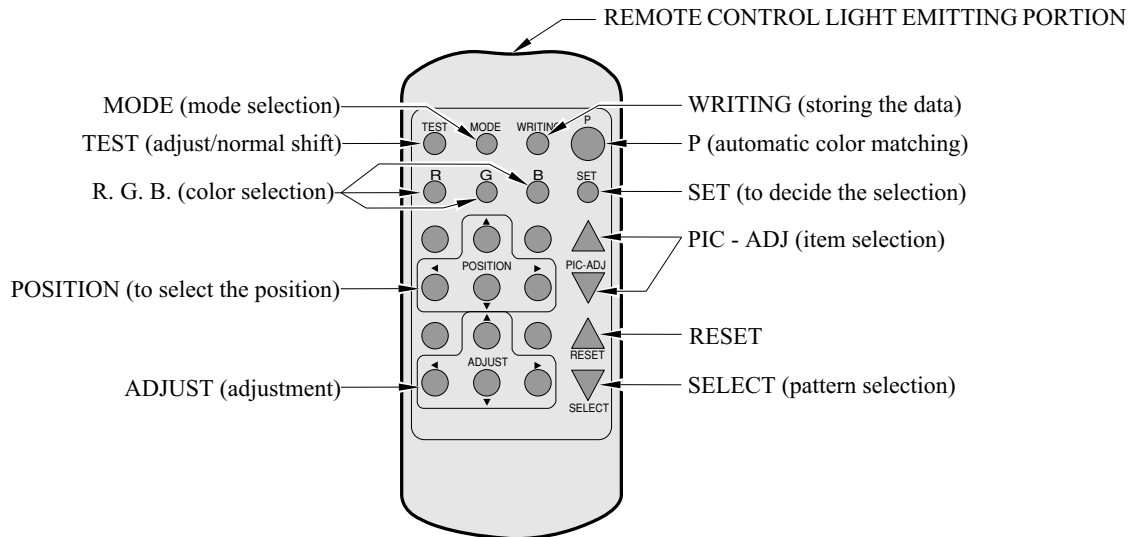

## AUTOMATIC COLOR MATCHING

The Projector may be subject to color deviations affected by earth magnetism, the building steel frames, etc. When the Projector is initially installed or the Projector's installation position is changed, have the color matching performed automatically.

- ① Keep pressing the P button (red) for approximately 3 seconds to have the ensuing movements performed automatically.

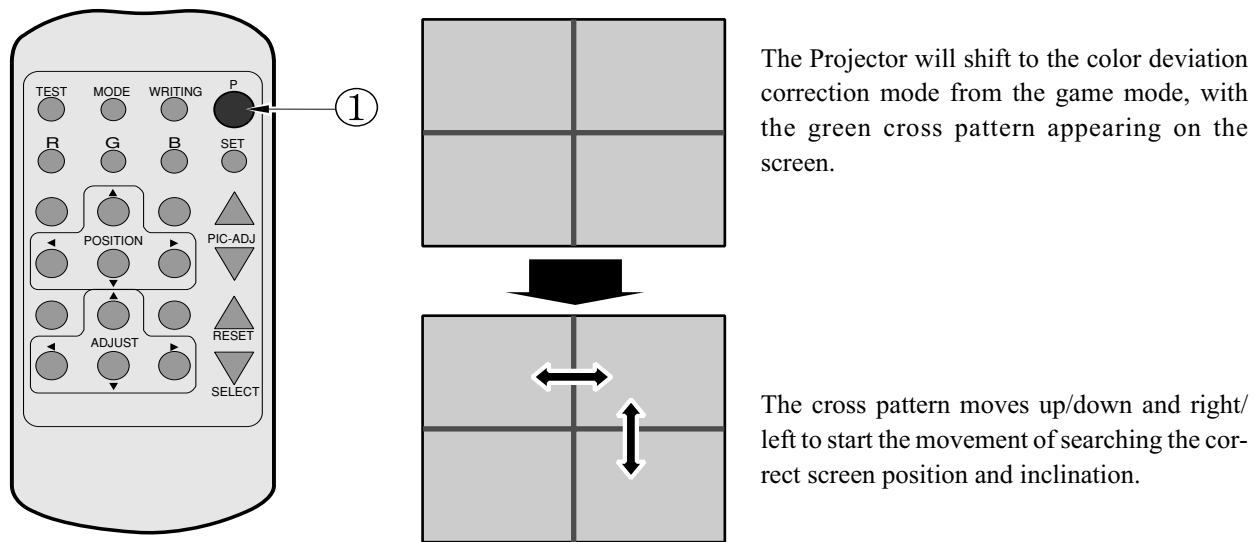

When the green cross pattern movements are finished, similar detection is performed sequentially in order of red and then blue cross movements. After detecting by green, red and blue cross movements, the game mode returns with the color deviation status being corrected.

- Although very rarely, the TRY AGAIN error display in red may appear. At this time, press the P button (red) for approximately 3 seconds. Even after the above operation is repeated, if the error condition still exists, then the display shifts to PLEASE ADJ. In this case, the auto color matching function can not be used. Contact the place of contact herein stated or where the product was purchased from.
- If the automatic color matching indicates an error, color matching can manually be performed. Refer to CONVERGENCE ADJUSTMENT (manual color matching).

## ADJUSTING THE ON-SCREEN CONTRAST

Although the on-screen picture quality has been adjusted at the time of shipment from the factory, the on-screen contrast can be readjusted if desired. When the Game Board is replaced, readjustment may be necessary. Changing the CONTRAST causes the light and shade of the on-screen images to be changed.

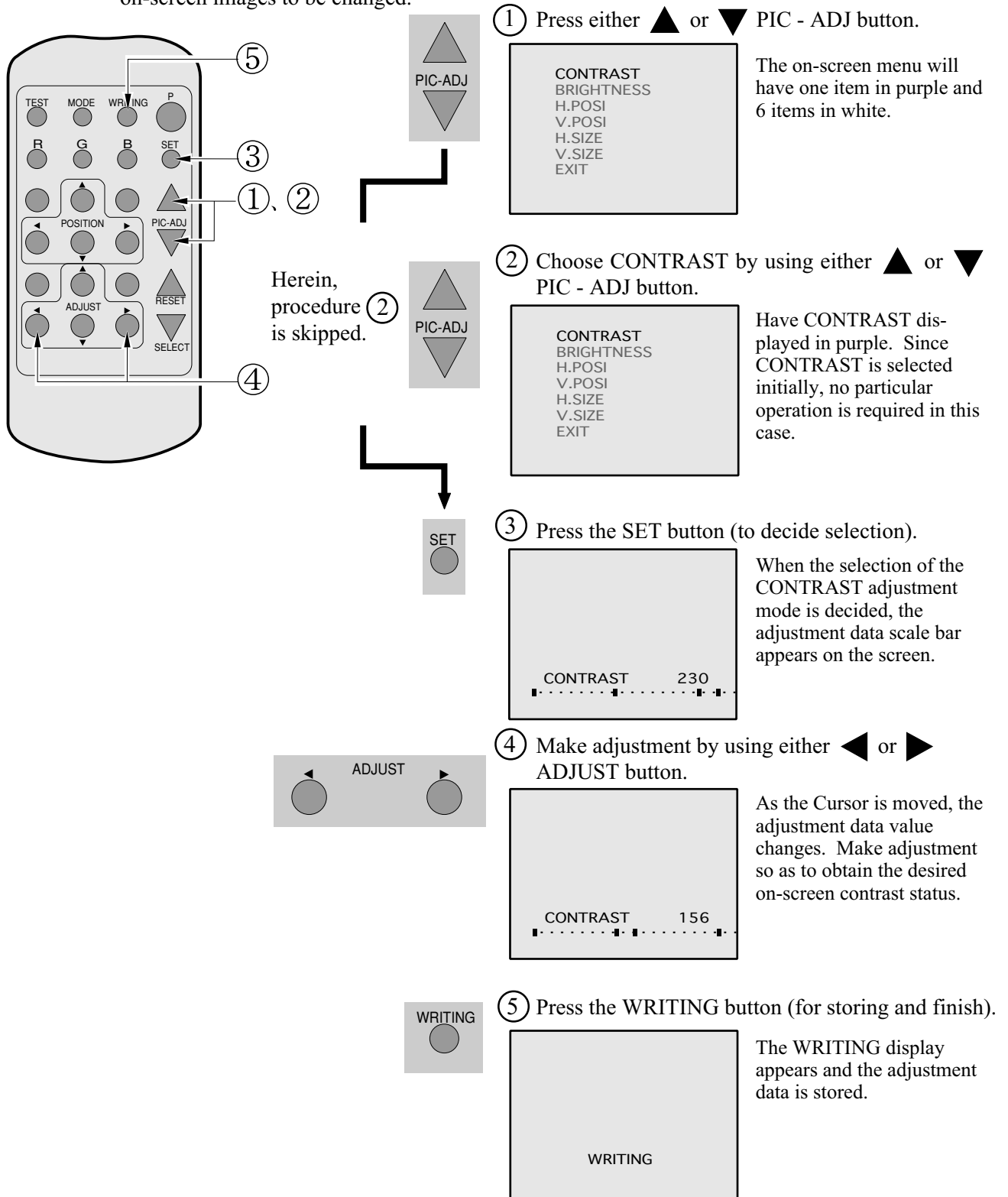

- When discontinuing the adjustment, choose EXIT from the menu at the stage of procedure ② and press the SET button.
- To continue adjusting other menu items, repeat procedure ② ~ ④.
- Unless the adjustment data is stored, the data in the adjusted status will be erased at the time the power is turned off and the pre-adjustment status will remain when the power is turned on next time.

## ADJUSTING THE SCREEN BRIGHTNESS

Although the on-screen picture quality has been adjusted at the time of shipment from the factory, readjustment can be made if desired. When the Game Board is replaced, readjustment may be necessary. Changing the BRIGHTNESS causes the brightness of the on-screen images of black portions to be changed.

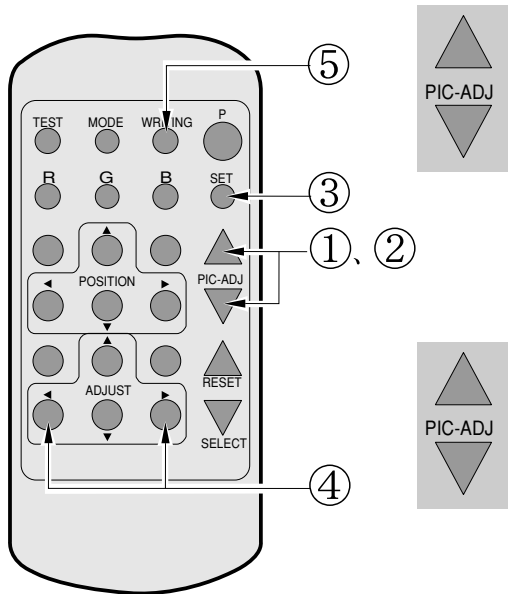

① Press either ▲ or ▼ PIC - ADJ button.

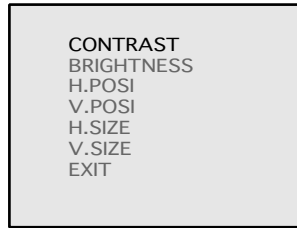

The on-screen menu will have one item in purple and 6 items in white.

② Choose BRIGHTNESS by using either ▲ or ▼ PIC - ADJ button.



Have the BRIGHTNESS displayed in purple.

③ Press the SET button (to decide selection).

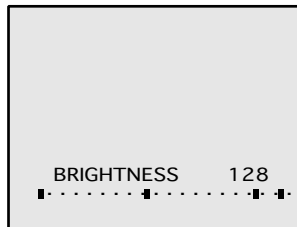

When the selection of the BRIGHTNESS adjustment mode is decided, the adjustment data scale bar appears on the screen.

④ Make adjustment by using either ◀ or ▶ ADJUST button.

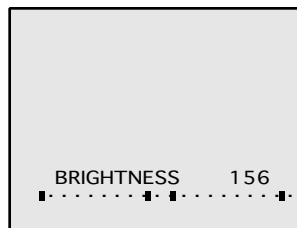

As the Cursor is moved, the adjustment data value changes. Make adjustment so as to obtain the desired on-screen brightness status.

⑤ Press the WRITING button (for storing and finish).

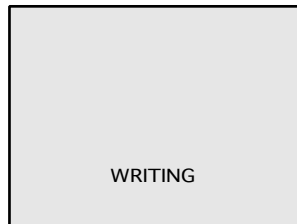

The WRITING display appears and the adjustment data is stored.

- When discontinuing the adjustment, choose EXIT from the menu at the stage of procedure ② and press the SET button.
- To continue adjusting other menu items, repeat procedure ② ~ ④.
- Unless the adjustment data is stored, the data in the adjusted status will be erased at the time the power is turned off and the pre-adjustment status will remain when the power is turned on next time.

## ADJUSTING THE ON-SCREEN DISPLAY POSITION

Although the on-screen display position (H. POSI, V. POSI) has been adjusted at the time of shipment from the factory, readjustment can be made if desired. When the Game Board is replaced, readjustments may be necessary.

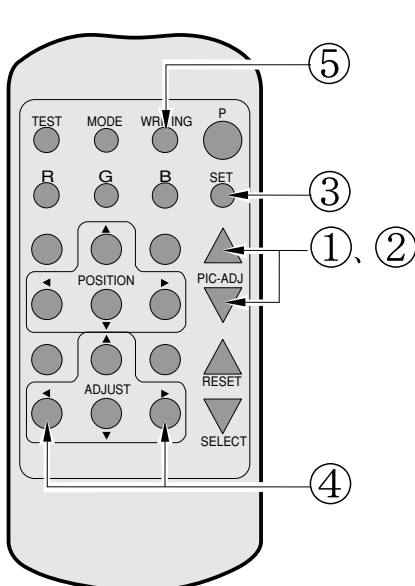

**①** Press either ▲ or ▼ PIC - ADJ button.

The on-screen menu will have one item in purple and 6 items in white.

```

CONTRAST
BRIGHTNESS
H.POSI
V.POSI
H.SIZE
V.SIZE
EXIT
    
```

**②** Choose H. POSI or V. POSI by using either ▲ or ▼ PIC ADJ button.

Have the H. POSI or V. POSI displayed in purple. The Figure shows the status in which H. POSI is selected.

```

CONTRAST
BRIGHTNESS
H.POSI
V.POSI
H.SIZE
V.SIZE
EXIT
    
```

**③** Press the SET button (to decide selection).

When the selection of the H. POSI or V. POSI is decided, the adjustment data scale bar appears on the screen.

```

H.POSI 128
┌-----┴-----┐
└-----┬-----┘
    
```

**④** Make adjustment by using either ◀ or ▶ ADJUST button.

As the Cursor is moved, the adjustment data value changes. Make adjustment so as to obtain the desired on-screen position status.

```

H.POSI 156
┌-----┴-----┐
└-----┬-----┘
    
```

**⑤** Press the WRITING button (for storing and finish).

The WRITING display appears and the adjustment data is stored.

```

WRITING
    
```

When making adjustments in vertical directions, also use either ◀ or ▶ ADJUST button.

- When discontinuing the adjustment, choose EXIT from the menu at the stage of procedure ② and press the SET button.
- To continue adjusting other menu items, repeat procedure ② ~ ④ .
- Unless the adjustment data is stored, the data in the adjusted status will be erased at the time the power is turned off and the pre-adjustment status will remain when the power is turned on next time.

## ADJUSTING THE SCREEN SIZE

Although the on-screen size (H. SIZE, V. SIZE) has been adjusted at the time of shipment from the factory, readjustment can be made if desired. When the Game Board is replaced, readjustments may be necessary.

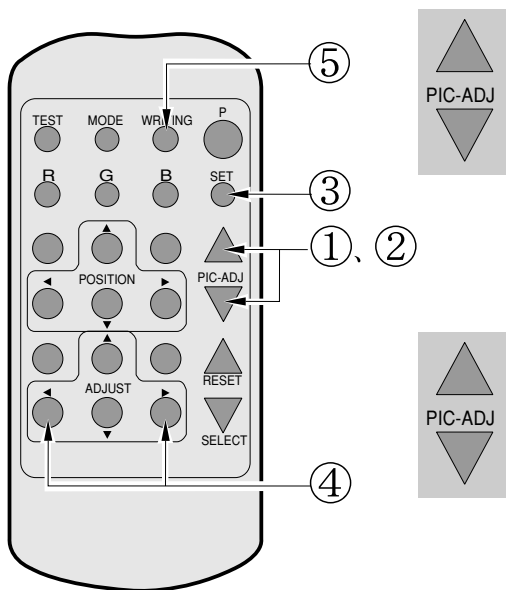

① Press either ▲ or ▼ PIC - ADJ button.

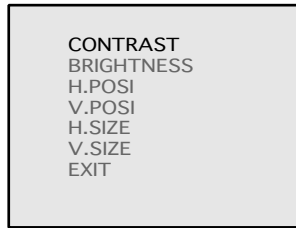

The on-screen menu will have one item in purple and 6 items in white.

② Choose H. SIZE or V. SIZE by using either ▲ or ▼ PIC - ADJ button.



Have the H. SIZE or V. SIZE displayed in purple. The Figure shows the status in which H. SIZE is selected.

③ Press the SET button (to decide selection).

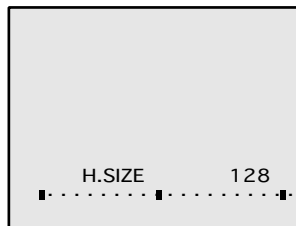

When the selection of the H. SIZE or V. SIZE adjustment mode is decided, the adjustment data scale bar appears on the screen.

④ Make adjustment by using either ◀ or ▶ ADJUST button.

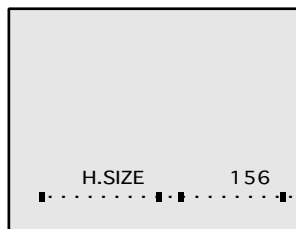

As the Cursor is moved, the adjustment data value changes. Make adjustment so as to obtain the desired on-screen position status.

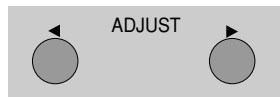

When making adjustments in vertical directions, also use either ◀ or ▶ button.

⑤ Press the WRITING button (for storing and finish).

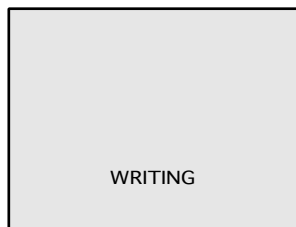

The WRITING display appears and the adjustment data is stored.

- When discontinuing the adjustment, choose EXIT from the menu at the stage of procedure ② and press the SET button.
- To continue adjusting other menu items, repeat procedure ② ~ ④.
- Unless the adjustment data is stored, the data in the adjusted status will be erased at the time the power is turned off and the pre-adjustment status will remain when the power is turned on next time.

## CONVERGENCE ADJUSTMENT (manual color matching)



CAUTION!

To avoid circuitry malfunctioning due to electrical load increase, never utilize CONVERGENCE ADJUSTMENT (Line Convergence Adjustment in particular) for adjusting screen size changes.

There is no means to restore the Convergence Adjustment data once stored, to its original state. To avoid changing the screen size by erroneously using convergence adjustment, do not perform the green Line Convergence Adjustment.

As such, be sure to perform the adjustment work from this page onward by the Technical staff and the location's Maintenance Personnel who are well versed in such adjustment work. In the Static Convergence Adjustments, if satisfactory adjustments can not be performed, do not make another convergence adjustments inadvertently. Contact the office herein stated or where the product was purchased from.



IMPORTANT

- To avoid making the adjustment work ineffective, do not press the RESET button during adjustment.
- To discontinue adjustment work, keep pressing the TEST button for approximately 3 seconds at the stage before storing the adjustment data by pressing the WRITING button.
- Should the screen be abnormally disturbed by noise due to static electricity, etc., turn the power off without storing the adjustment data.
- Pressing the ▲ or ▼ - ADJ button in the Convergence Adjustment mode status will display the Adjustment Menu shown right. Do not utilize this Adjustment Menu as this is the one applied at the factory.

Adjusting this menu causes the Customer's adjustment range to be deviated.

Should the menu shown right be displayed by mistake, first choose EXIT by using either ▲ or ▼ - ADJ button and then press the SET button.

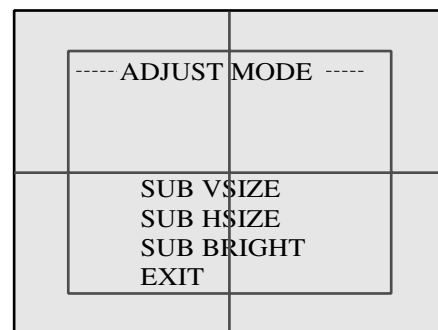

Adjustment menu used in the factory.



## STATIC CONVERGENCE ADJUSTMENT

In the static convergence adjustment, each of red and blue images is comprehensively moved to and superimposed on the green color. If automatic color matching function is not sufficiently satisfactory, perform this adjustment. Be sure to perform automatic color matching before starting the above adjustment.

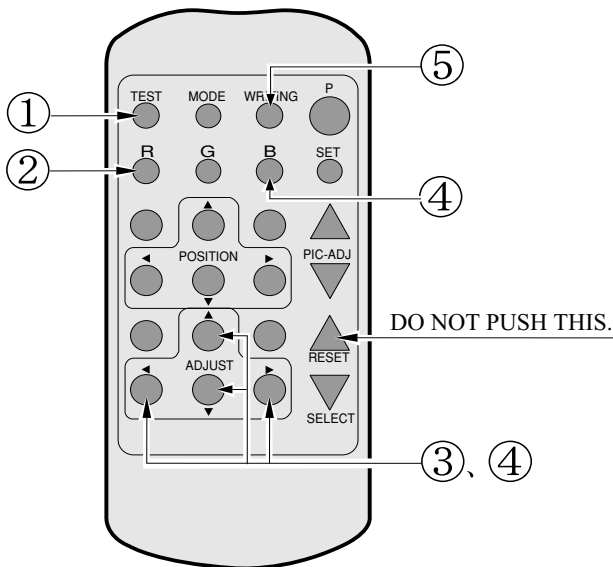

When either of (2) (4) COLOR SELECT buttons (R, B) is pressed, if the color desired to be adjusted disappears, press that particular button again. For example, if the red color needs to be adjusted again at the stage of (4), the R button need to be pressed twice.

- Keep pressing the TEST button for approximately 3 seconds.

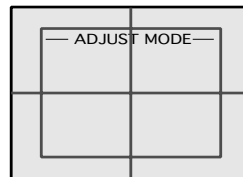

The screen will change to ADJUST mode from the Game mode to cause the green test pattern to be displayed on the screen.

- Press the R button to have the red adjustment mode.

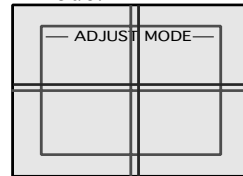

The red test pattern is added to the display. The frame color turns red and this signifies the red adjustment mode.

- Make adjustment by using the ▲ ▼ ◀ ▶ ADJUST buttons.

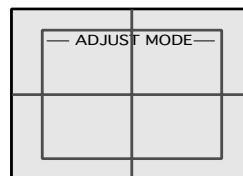

Make adjustment so as to have red superimposed on green. When red is superimposed on green, the color becomes yellow.

- Press the B button to have the blue adjustment mode.

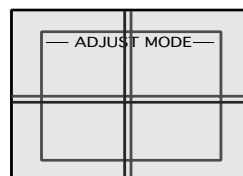

Similarly as in the case of red, adjust the blue color. When green, red, and blue are superimposed, the color becomes white.

- Press the WRITING button (for storing and finish).

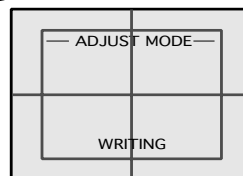

The WRITING display appears and the adjustment data is stored. After the data is stored, the Game mode returns.

## POINT CONVERGENCE ADJUSTMENT

In the POINT CONVERGENCE adjustment, each of red, green and blue images is partially moved for color matching. The adjustment may be necessary when the Game Board is replaced or changed, or screen size is changed. Be sure to perform automatic color matching before starting the adjustment.

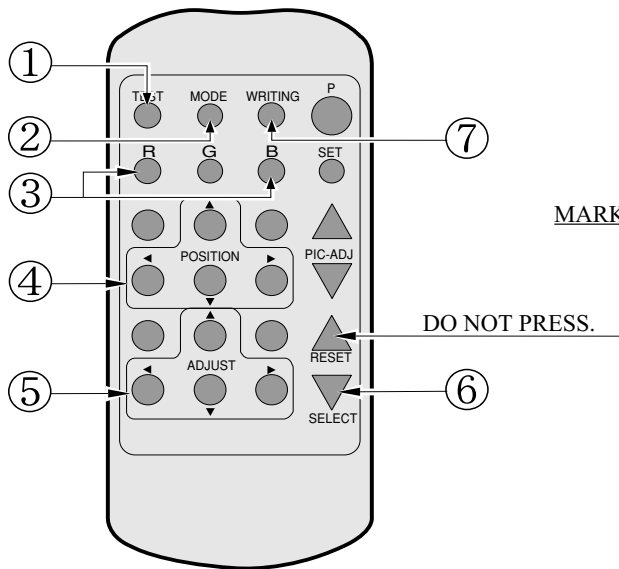

Note 1 When the MODE button is repeatedly pressed, the adjustment modes will circulate as follows:

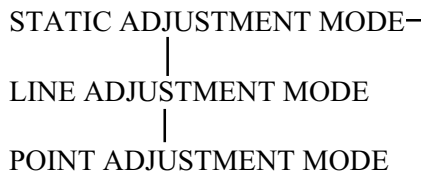

Note 2 When either of the COLOR SELECT buttons (R, B) is pressed, if the desired color to be adjusted disappears, press that particular button again.

Note 3 By repeatedly pressing the SELECT button, only the Projector's TEST pattern screen and the screen superimposing the Game Board Test pattern can be alternately displayed.

- ① Keep pressing the TEST button for approximately 3 seconds.

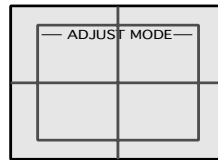

The screen changes to ADJUST mode from the Game mode and displays the green test pattern.

- ② Press the MODE button twice to have the POINT ADJUSTMENT mode. Note 1

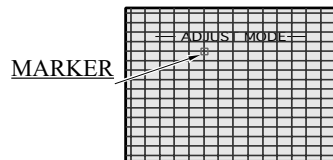

The crosshatch test pattern appears and the MARKER indicating the adjustment point is displayed.

- ③ Using either R or B button, select the desired color to be adjusted. Note 2 By using the G button, the green color can also be selected.

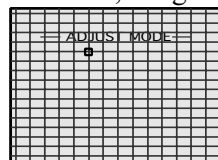

The selected color is displayed by superimposing on green. The MARKER will be in the color selected.

- ④ By using the ▲ ▼ ◀ ▶ ADJUST buttons, move the MARKER to the position to be adjusted.

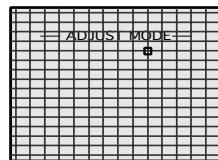

The MARKER moves in the direction of the button's arrow. However, the movable point is predetermined.

- ⑤ Make adjustment by using the ▲ ▼ ◀ ▶ ADJUST buttons.

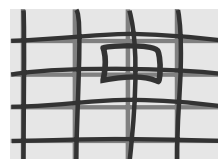

Although the direct vicinity of the MARKER's center moves most conspicuously, make adjustment by paying attention to the periphery area also. Shown left is the magnified MARKER periphery.

- ⑥ Press the SELECT button as necessary to superimpose Game Board images. Note 3

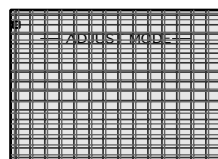

If the test pattern is not displayed in the periphery of the screen, adjustments can be made by pressing the SELECT button to superimpose the test pattern and the Game Board's CRT test screen.

- ⑦ Press the WRITING button (for storing and finish).

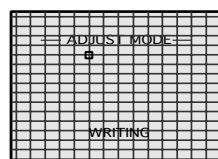

WRITING is displayed and the adjustment data is stored. After the data is stored, the Game Board screen returns.

## LINE CONVERGENCE ADJUSTMENT

In the LINE CONVERGENCE ADJUSTMENT, the adjustment point of the column line (vertical) or row line (horizontal) is comprehensively moved for color matching. It is convenient to utilize this adjustment when the color of the column line or row line is uniformly deviated.

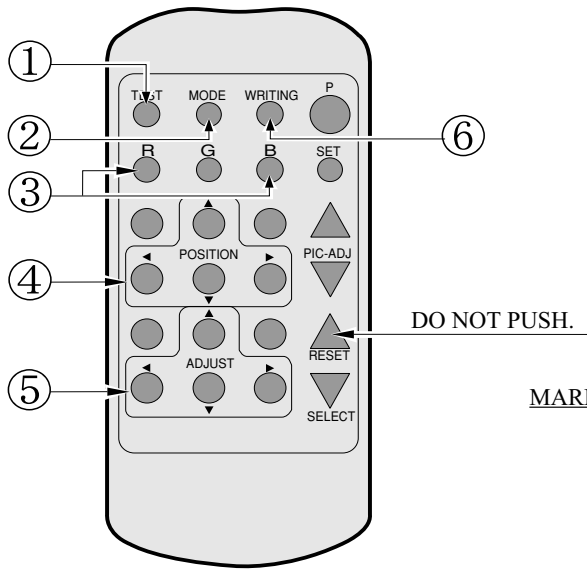

- ① Keep pressing the TEST button for approximately 3 seconds.

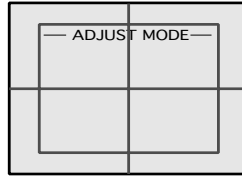

The screen changes to ADJUST mode from the Game Board mode and displays the green test pattern.

- ② Press the MODE button once to have the POINT ADJUSTMENT mode. Note 1

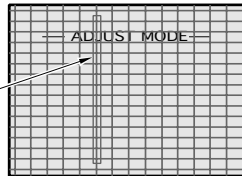

The crosshatch test pattern appears and the vertically long MARKER is shown.

- ③ Using either R or B button, select the desired color to be adjusted. Note 2 Although the green color can also be selected by using the G button, to avoid the screen size change adjustment, do not choose green.

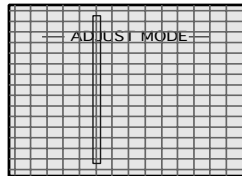

The selected color is displayed by superimposing on green. The MARKER will be in the color selected.

- ④ By using the ▲ ▼ ◀ ▶ POSITION buttons, move the MARKER to the position to be adjusted.

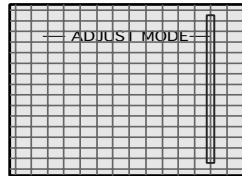

Use the ◀ ▶ buttons to select the column line, and the MARKER moves in the right/left direction. However, the movable range is predetermined.

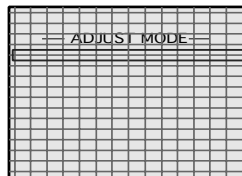

Use the ▲ ▼ buttons to select the row line and the MARKER moves in the up/down direction. However, the movable range is predetermined.

- ⑤ Make adjustment by using the ▲ ▼ ◀ ▶ ADJUST buttons.

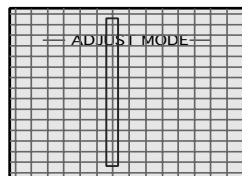

The selected column line or row line (shown left is the column line) can be moved in the desired up/down or right/left directions as applicable.

- ⑥ Press the WRITING button (for storing and finish).

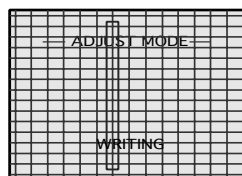

WRITING is displayed and the adjustment data is stored. After the data is stored, the Game Board screen returns.

Note 1 When the MODE button is repeatedly pressed, the adjustment modes will circulate as follows:

STATIC ADJUSTMENT MODE  
 LINE ADJUSTMENT MODE  
 POINT ADJUSTMENT MODE

Note 2 When either of the COLOR SELECT buttons (R, B) is pressed, if the desired color to be adjusted disappears, press that particular button again.

### 13. REPLACING THE FLUORESCENT LAMP, AND LAMPS



- When performing work, be sure to turn power off. Working with power on can cause electric shock and short circuit hazards.
- The Fluorescent Lamp, when it gets hot, can cause burn. Be very careful when replacing the Fluorescent Lamp.
- Be sure to use lamps of the designated rating. Using lamps of undesignated rating can cause a fire or malfunctioning.



- To perform work safely and securely, be sure to prepare a step which is in a secure and stable condition. Performing work without using the step can cause violent falling down accidents.
- Be careful when handling the plastic made parts. Failure to observe this may cause injury due to damage or fragments resulting from damage.

#### INSIDE THE BILLBOARD

Remove the billboard holder, slide up the billboard, and replace the fluorescent tube.

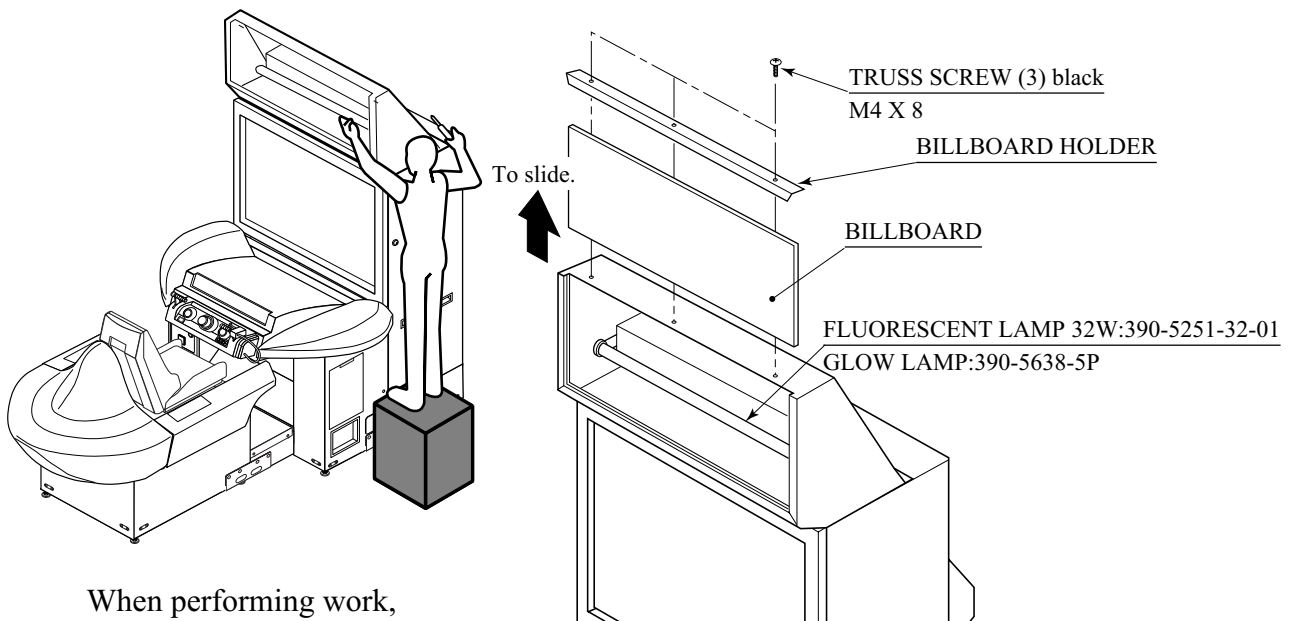

When performing work,  
prepare a step.

FIG. 13 a

## START BUTTON

- ① Turn power off.
- ② Take out the 4 screws to remove the ASSY START SW from the CONTROL PANEL. The wiring connection is inside the ASSY START SW. Use care so as not to damage wiring. The SW PLATE is a plastic-made part. Handle with care.
- ③ Carefully pull out and remove the wire connector of the ASSY START SW.

ASSY START SW



TRUSS SCREW (4) black  
M4 X 12



PHOTO 13 a

Disconnect the connector.

- ④ Hold the SW portion of the START button and remove from the START button.
- ⑤ Pull out the lamp horizontally and replace. Do not rotate the lamp at this time.

LAMP 6V 3W  
390-5160

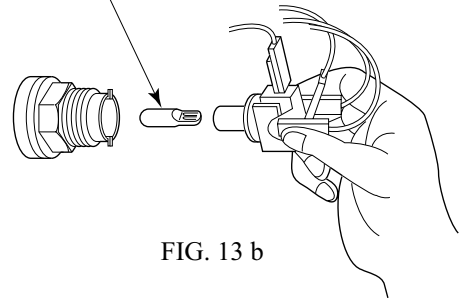

FIG. 13 b

START button is located  
in the upper right.

- ⑥ When installing the ASSY START SW to the CONTROL PANEL, be careful of the inserting direction. Install the ASSY START BUTTON in the manner the START button terminal is located in the upper right.



PHOTO 13 b

## 14. PERIODIC INSPECTION TABLE

The items listed below require periodic check and maintenance to retain the performance of this machine and to ensure safe business operation.

When handling the controller, the player will be in direct contact with it . In order to always allow the player to enjoy the game, be sure to clean it regularly. Also, it is advisable to provide wet tissue, etc. available for player use.



- Be sure to check once a year to see if Power Cords are damaged, the plug is securely inserted, dust is accumulated between the Socket Outlet and the Power Plug, etc. Using the product with dust as is accumulated can cause fire and electric shock hazards.
- Periodically once a year, request the place of contact herein stated or the Distributor, etc. where the product was purchased from, as regards the internal cleaning. Using the product with dust as is accumulated in the interior without cleaning can cause a fire or accident. Note that cleaning the interior parts can be performed on a pay-basis.

TABLE 14

	Item	Interval	Reference
CABINET	Check Adjusters'contact with surface.	Daily	3
CONTOROL PANEL	Cleaning	As necessary	
	Inspection of SW, VR.	Monthly	9
	Greasing to the gear mesh portion and the spring.	Trimonthly	10-3
	Greasing to the BOOST button.	Semiannually	10-3
COIN CHUTE DOOR	Check COIN SW.	Monthly	9
	Coin insertion test.	Monthly	11
	Cleaning of COIN SELECTOR.	Trimonthly	11
PROJECTOR	SCREEN cleaning.	Weekly	12-1
	Check adjustments.	Monthly or when moving.	6, 9, 12
SEAT	An anti-static electricity measure.	Bimonthly	5
	Greasing to the seat rail	Trimonthly	FIG.14
GAME BD	MEMORY TEST.	Monthly	9
	Check settings.	Monthly	9
INTERIOR	Cleaning	Annually	See above.
POWER SUPPLY PLUG	Inspection and cleaning		
Cabinet surfaces	Cleaning	As necessary.	See below.

### CLEANING THE CABINET SURFACES

When the cabinet surfaces are badly soiled, remove stains with a soft cloth dipped in water or diluted (with water) chemical detergent and squeezed dry. To avoid damaging surface finish, do not use such solvents as thinner, benzene, etc. other than ethyl alcohol, or abrasives, bleaching agent and chemical dustcloth.

SEAT (Greasing to Seat Rail Portion)

Move the Seat to the rearmost portion and apply spray greasing to the portion shown at the right once every 3 months by using NOK KLUBER L60 or GREASE MATE SEGA PART No. 090-0066. After greasing, move the Seat a few times forward and backward so as to allow the grease to be applied all over uniformly. Be sure to wipe grease which attaches to the surfaces of the PROTECT RUBBER on the Seat Rail, or any excess grease.

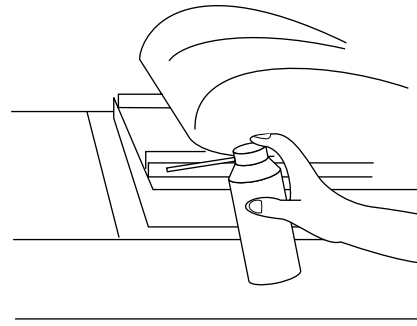

FIG. 14

# 15. TROUBLESHOOTING



- In order to prevent electric shock and short circuit, be sure to turn power off before performing work.
- Be careful so as not to damage wirings. Damaged wiring can cause electric shock or short circuit.
- After removing the cause of the functioning of the Circuit Protector, reinstate the Circuit Protector. Depending on the cause of the functioning, using the Circuit Protector as is without removing the cause can cause generation of heat and fire hazard.

In case a problem occurs, first check wiring connector connections.

TABLE 15 a

PROBLEMS	CAUSE	COUNTERMEASURES
With Main SW ON, no activation.	Power is not supplied.  Power supply/voltage is not correct.  The Circuit Protector functioned due to the momentary overload.	Securely insert the power plug into the plug socket.  Make sure that power supply/voltage is correct.  After eliminating the cause of overload, reinstate the AC Unit's Circuit Protector (see 4 , Section 6, Refer to the following).
The color on PTV screen is incorrect.	Image adjustment is inappropriate.	Adjust appropriately (see Sec.12).
Color deviation on PTV screen.	Affected by peripheral machines or the building's steel frames.	Perform convergence adjustment (see Sec. 12).  Change installation direction or position.  Move the machine which causes the problem.

CIRCUIT PROTECTOR

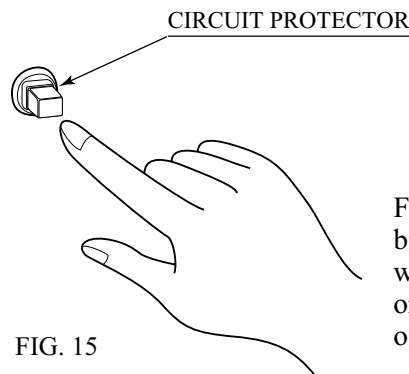

Functions due to the activation of bimetal. To restore the function, wait for approximately one minute or longer until the bimetal cools off. (Press the Button.)

FIG. 15



TABLE 15 b

PROBLEMS	CAUSE	COUNTERMEASURES
No sound is emitted.	Sound volume adjustment is not appropriate. Board and Amplifier malfunctioning.	Adjust sound volume (see Sec. 9). Perform the sound test and confirm (see Sec. 9).
Operability of the Control Panel is poor.	Deviation of the volume value. Volume gear engagement fault. Volume malfunctioning.	Adjust the volume value in the Test mode. (see 9-3) Adjust the engagement of the gear. (see 10-2) Replace the Volume. (see 10-2)
The Fluorescent lamp does not light up.	The Fluorescent tube is burnt out.	Replace the Fluorescent tube (see Sec. 13).
START button does not light up.	The lamp is burnt out.	Replace the lamp. (see Sec.13)

**ERROR DISPLAY**

In this product, if an error is detected, the error message will be displayed at the lower right screen. There are 2 kinds of error messages, BOOST ERROR and SOLENOID ERROR. Enter the test mode and exit from it to erase the error message. Turning power on again does not erase the error message. If the error is caused by mechanical fault, game cannot be played. Remove the cause of the malfunctioning to ensure satisfactory operation.

**BOOST ERROR**

PROBLEM: The BOOST button is in a state of being pressed down.

**SOLENOID ERROR**

PROBLEM: The lock mechanism of the BOOST button does not function.

The following causes of the BOOST ERROR can be considered.

- The BOOST button has been pressed down.
- The BOOST button is in a state of pressed down with an extraneous matter put inside it.
- The BOOST button is in a state of locked due to lock mechanism fault or malfunctioning.
- Malfunctioning of the BOOST button sensor.
- An extraneous matter is put in the BOOST button sensor.

The following causes of the SOLENOID ERROR can be considered.

- Malfunctioning of the Solenoid.
- The BOOST button cannot be locked due to lock mechanism fault or malfunctioning.
- Malfunctioning of the BOOST button sensor.

## 16. GAME BOARD



WARNING!

- In order to prevent electric shock and short circuit hazards, be sure to turn power off before performing work.
- Be careful so as not to damage wirings. Damaged wiring can cause fire, electric shock and short circuit hazards.
- Do not expose the Game BD, etc. without a good reason. Failure to observe this can cause electric shock hazard or malfunctioning.



CAUTION!

The electronic parts on the IC Board could be damaged due to human body's static electricity. Before performing IC Board related work, be sure to discharge physically accumulated statics by touching grounded metallic surfaces, etc.



IMPORTANT

Put the Game Board in the Carton Box (an accessory) together with the Shield Case when requesting for the replacement or repair. Transporting the Game Board in an undesignated status for replacement/repair is unacceptable. In this manual, how to remove the Game Board is explained for convenience. However, this work should be performed by SEGA SERVICEMAN.

## 16 - 1 REMOVING THE GAME BOARD

The REAR CABI inside is separated into the upper and the lower sections. The ASSY MAIN BOARD that carries the Shield Case containing the GAME BOARD on it is on the upper section.

- ① Turn off power.
- ② Take out the 2 screws, unlock, and remove the SIDE DOOR from the REAR CABI. (FIG. 16. 1 a)
- ③ Disconnect all connectors connecting to the wire inside the REAR CABI from the ASSY MAIN BOARD DX. (PHOTO 16. 1 a)
- ④ Disconnect the 2 optical fiber cables, the D-SUB 15P Connector, and the USB shape Connector among the connectors connecting to the Shield Case on the ASSY MAIN BOARD DX. (PHOTO 16. 1 b)
- ⑤ Take out the 2 Wing bolts securing the wooden base that carries the ASSY MAIN BOARD on it.(FIG. 16. 1 a)

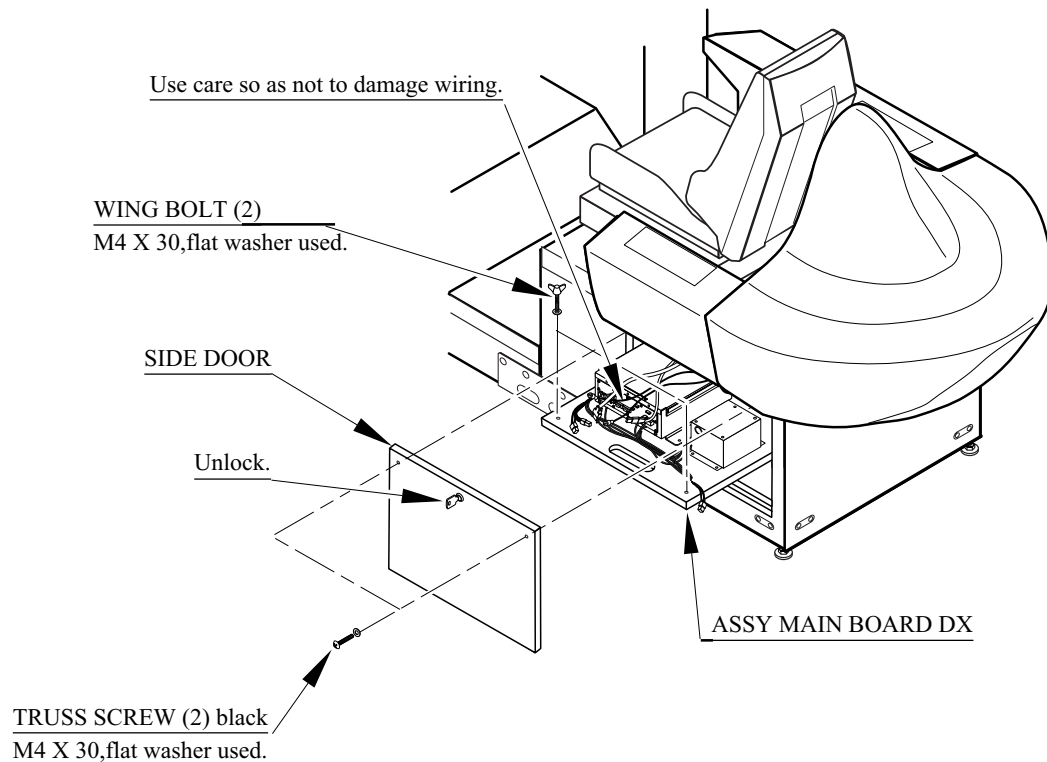

FIG. 16. 1 a

Disconnect the connector.



PHOTO 16.1 a

Disconnect the connector.

OPTIC FIBER CABLE (2)



PHOTO 16.1 b

D-SUB 15P CONNECTOR (1)

USB SHAPE CONNECTOR (1)

- ⑥ Remove the ASSY MAIN BOARD DX from the REAR CABI. Since the ASSY MAIN BOARD is heavy, in order to protect wiring, be sure to perform work by 2 or more workers.

To perform work safely,  
use 2 or more workers.

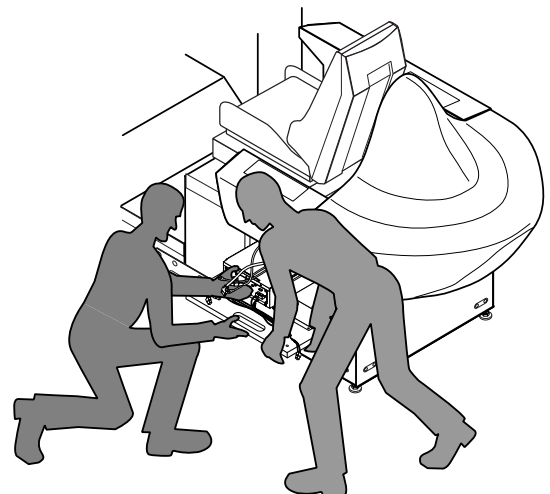

FIG. 16.1 b

- ⑦ Disconnect all connectors connected to the Shield Case.
- ⑧ Take out the 4 screws which secure the Shield Case to the base and remove the Shield Case from the base. Take out the 3 screws to remove the Shield Case Lid, and the Game Board appears. However, those other than Sega Serviceman should never perform this work.
- ⑨ Take out the 2 screws to remove the 2 Shield Case Brackets from the Shield Case. Pack up the Shield Case with packing materials, put it into a carton box, and request service.

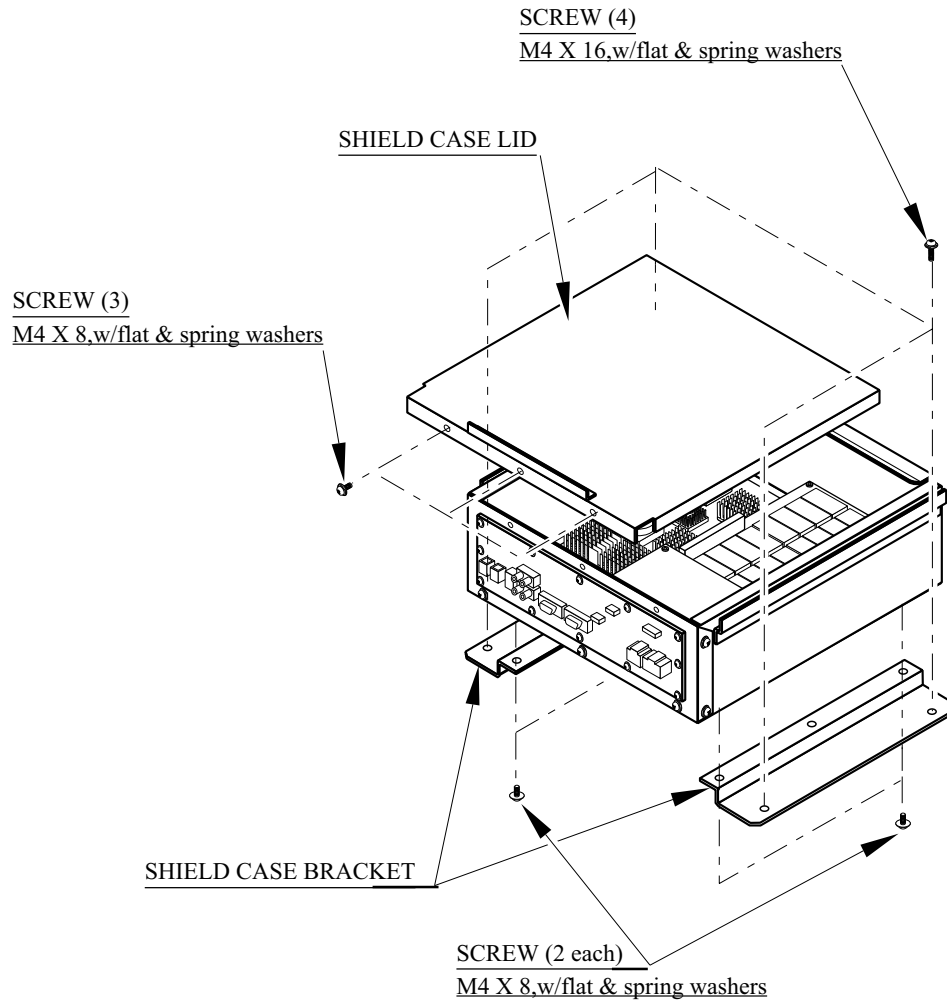

FIG. 16. 1 c

## 16 - 2 COMPOSITION OF GAME BOARD

GAME BD PO (833-14003)

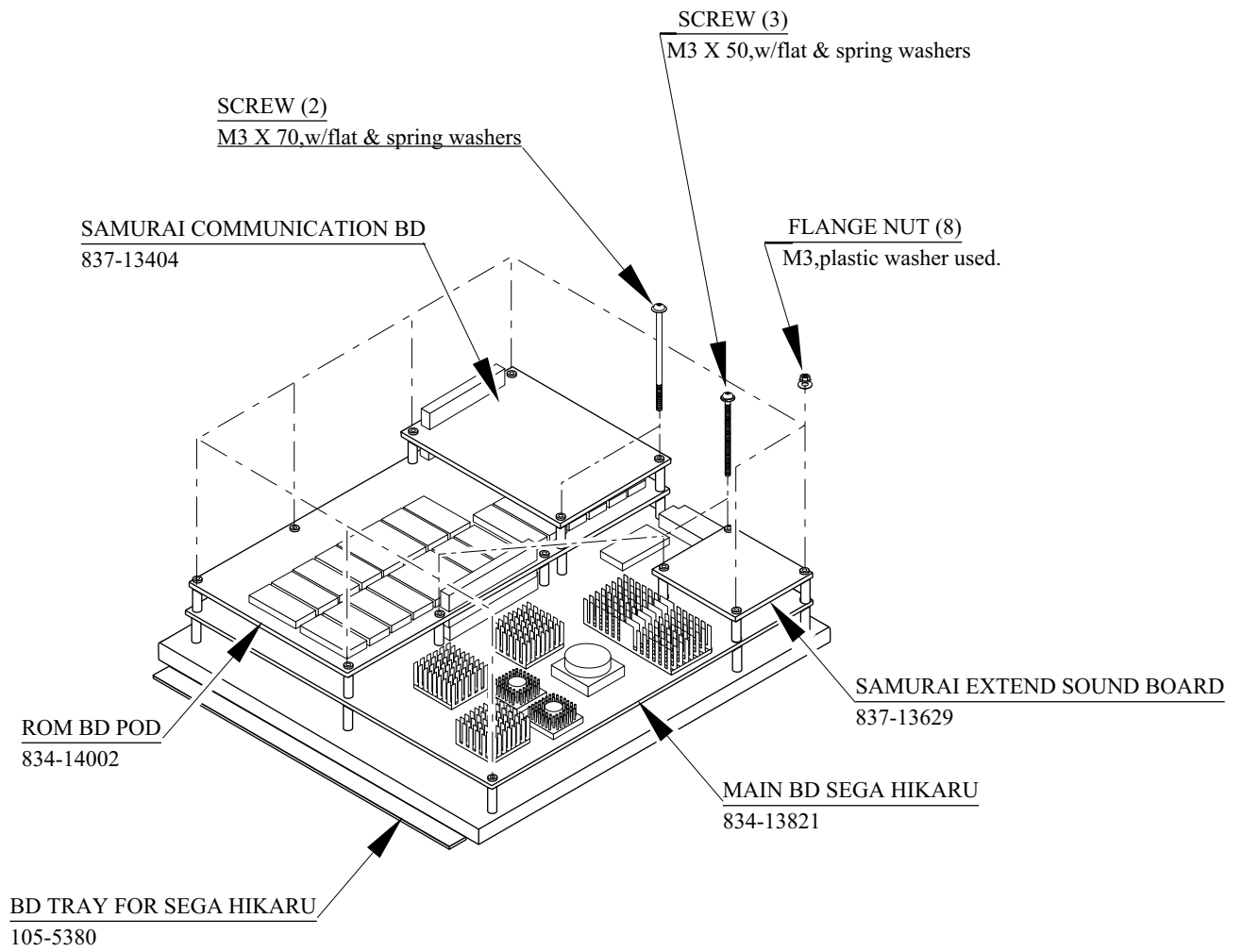
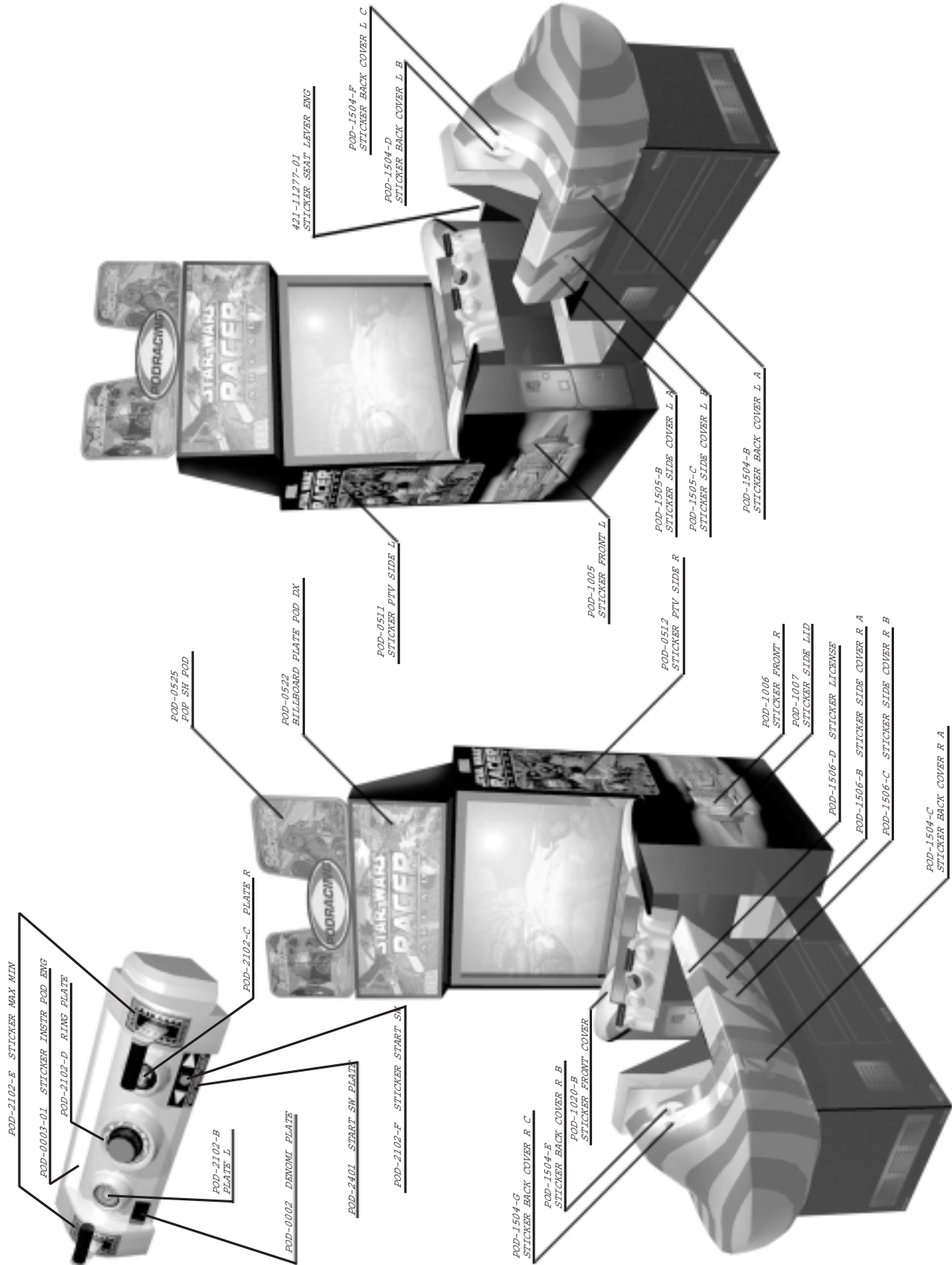

FIG. 16. 2

MAIN BD JUMPER SETTING	
JP4	1-2
JP5	1-2
JP6	1-2
JP7	1-2
JP8	2-3
JP9	2-3
JP10	1-2
JP11	2-3

# 17. DESIGN RELATED PARTS

For the Warning Display stickers, refer to Section 1.



## 18. COMMUNICATION PLAY

For this game, up to 4 machines can be connected to allow up to 4 players to play simultaneously. In this instance, connecting the communication cable and setting for the communication play are required.

### 18 - 1 INSTALLATION PRECAUTIONS



- Before starting to work, ensure that the Power SW is OFF. Failure to observe this can cause electric shock or short circuit.
- Use care so as not to damage wirings. Damaged wiring can cause electric shock or short circuit.
- Do not touch undesignated places. Touching places not designated can cause electric shock or short circuit.
- This work should be performed by the Location's Maintenance Man or Serviceman. Performing work by non-technical personnel can cause electric shock hazard.
- When linking a number of machines, be sure to supply sufficient power for the corresponding number of machines. Be sure to secure per machine current as stated in this manual. Failure to observe this can cause a fire and an electric shock accident.
- Due to the length of the communication cable, the distance in between the machines is limited. However, to avoid accidents, be sure to secure space in excess of 70 cm between the machines.
- In order to avoid personal injury, when separating the machine into each CABI, pay attention so as not to cause the PTV to fall down.
- To perform work safely and avoid serious accident such as the cabinet's falling down, do not perform work in places where step-like grade differences, a ditch, or slope exist.



To perform work safely, be sure to secure the space corresponding to number of machines to be linked. Failure to observe this can cause accident.



The optic fiber cable is used for the communication linkage. Excessive bending may damage the communication cable. Be very careful in this regard.

Since 2 or more machines are to be linked, sufficient power corresponding to the number of machines used need to be supplied. Note that as a standard, the per machine capacity should be 15A for the 100 ~ 120V area, and 7A for the 220 ~ 240V area.



## DISTANCE BETWEEN MACHINES

Be sure to secure space in excess of 70cm between machines.

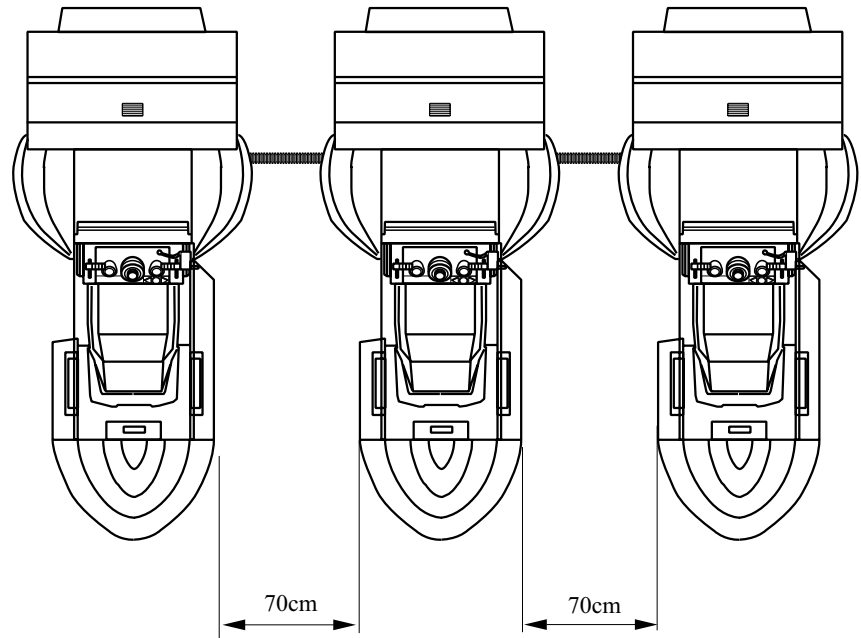

FIG. 18. 1

### 18 - 2 CONNECTING THE COMMUNICATION CABLE

Link the number of machines necessary for communication play by connecting the Communication Cable to the game board of the machine for each. Inside the REAR CABI the communication cable has been wired to the Connector Panel from the GAME BD. There are 2 connectors inside the Connector Panel for connecting the Communication Cable, besides the connector for wiring connection between the FRONT CABI and the REAR CABI. Pass the Communication Cable through the FRONT CABI to connect to the Connector Panel in the REAR CABI, and connection of the GAME BD for each machine is completed. To perform work, prepare the Flex Tube, the Connector 29, the Communication Cable, and the Connector Bracket (accessories).

- ① Turn off power and disconnect the plug. From the viewpoint of protecting, disconnect the power cord.
- ② Remove the Floor Lid by referring to Sec.6 and separate the machine into "PTV BASE, PTV, BILLBOARD", "FRONT CABI", and "REAR CABI." Wiring connection is in-between each unit. Use care so as not to damage wiring. Do not push the PTV BASE, the PTV, and the BILLBOARD to avoid causing to fall down.

- ③ Remove the Connector Lid from the side of the FRONT CABI by taking out the 2 truss screws.



PHOTO 18. 2 a

- ④ Attach Connector 29 to the both ends of Flex Tube by inserting the Flex Tube end into the Connector 29.

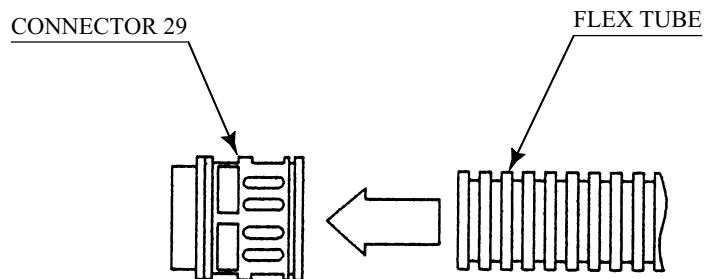
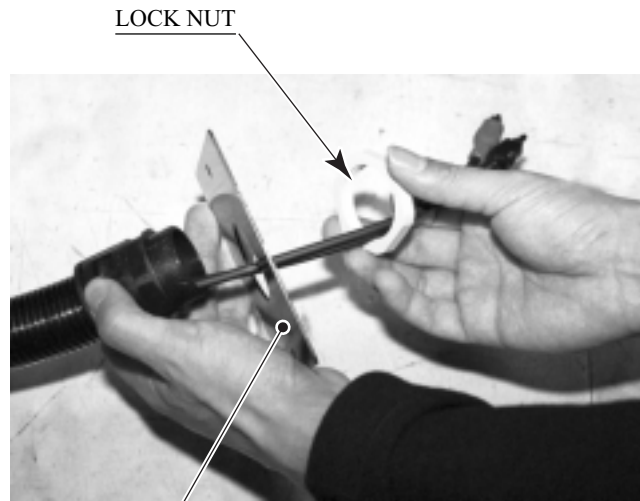

FIG. 18. 2 a

- ⑤ Pass the Communication Cable through the Flex Tube.
- ⑥ Remove the Lock Nut from the Connector 29.
- ⑦ Install the Connector 29 into the Connector Bracket hole and tighten the Lock Nut.



CONNECTOR BRACKET

PHOTO 18. 2 b

- ⑧ Pass the Communication Cable through the square hole of the side of the FRONT CABI and perform wiring so as to allow the connector head to connect to the Connector Panel of the REAR CABI. Depending on the number of machines to be linked, the connecting point of the Communication Cable alters. (FIG. 18. 2 b)

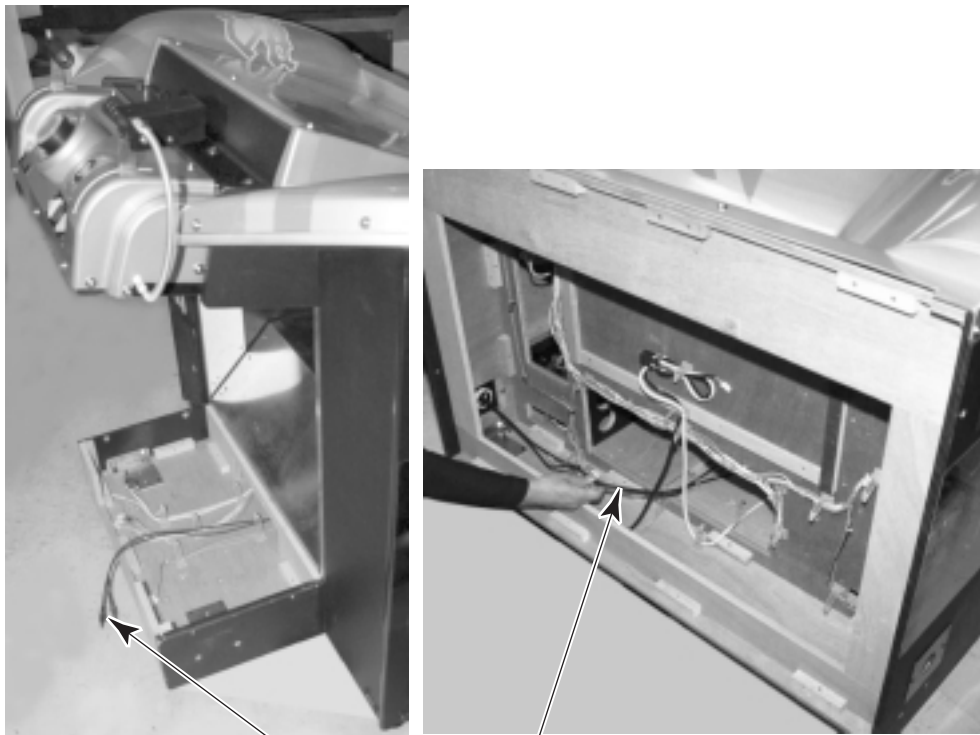

PHOTO 18. 2 c

COMMUNICATION CABLE

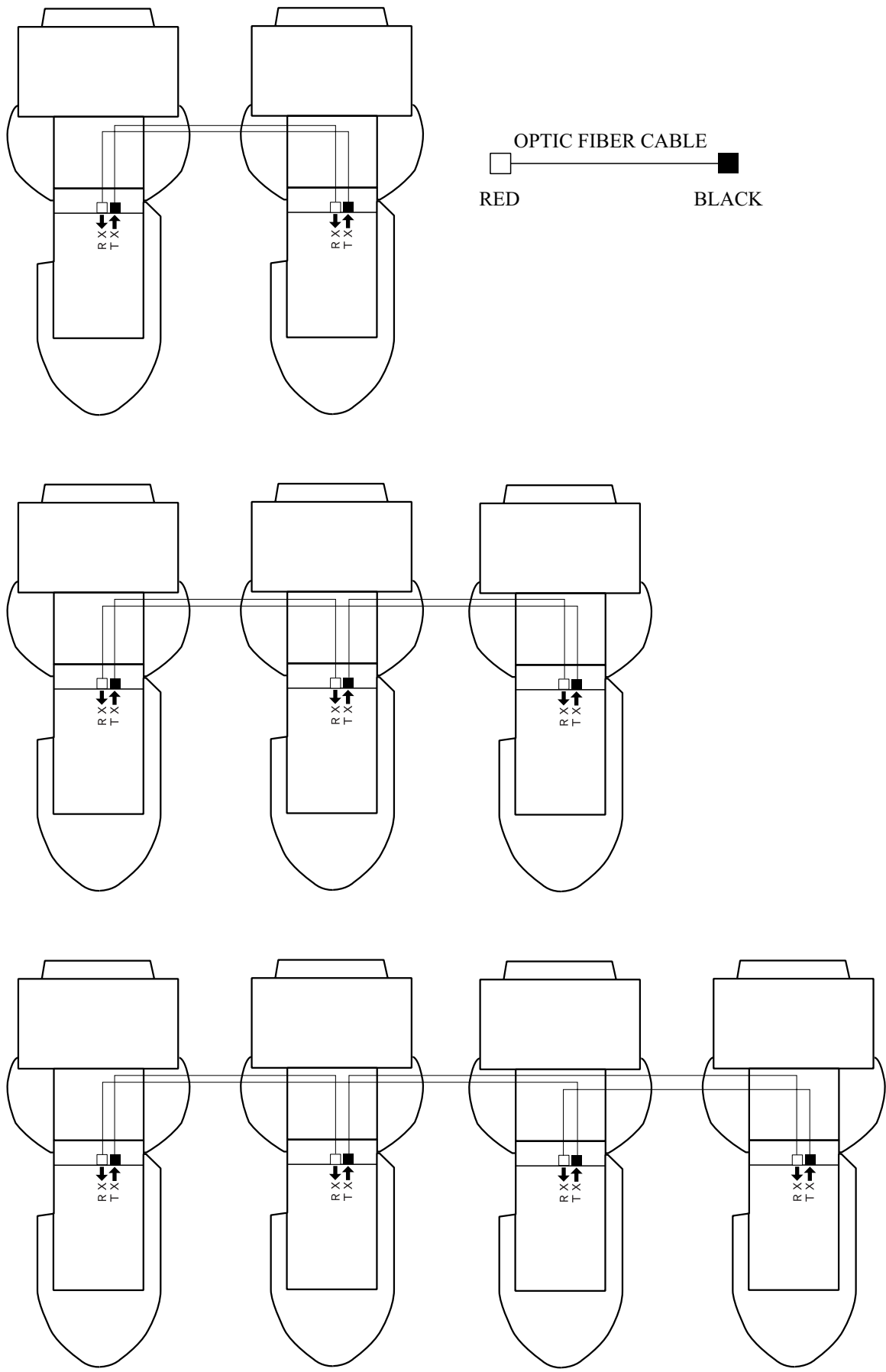

FIG. 18. 2 b

- ⑨ By using the 2 truss screws which were used for securing the Connector Lid, secure the Connector Bracket to the side of the FRONT CABI.

TRUSS SCREW (2) black  
M4 X 20

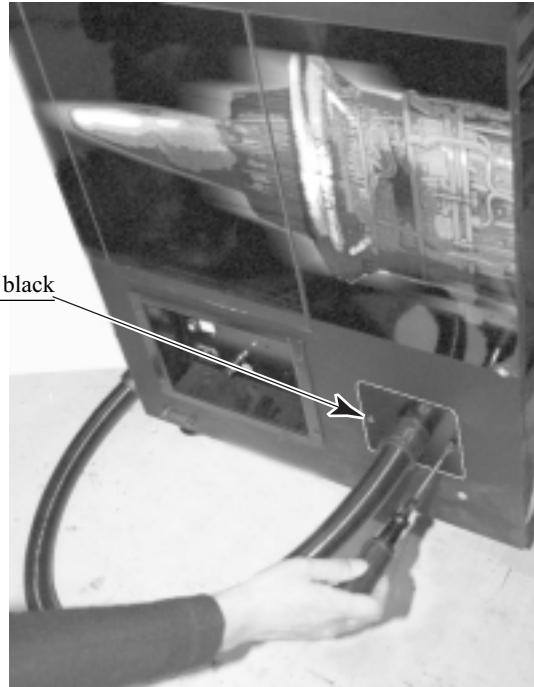
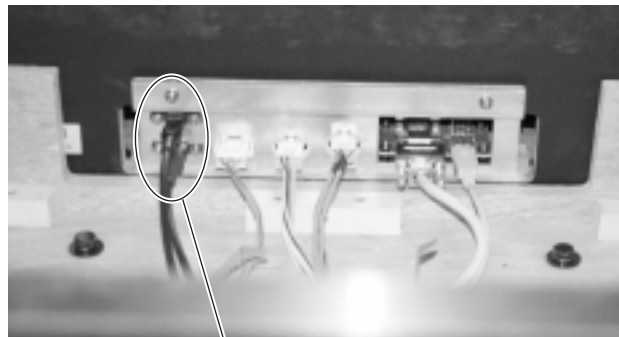

PHOTO 18. 2 d

- ⑩ Re-join the "PTV BASE, PTV, BILLBOARD", "FRONT CABI", and "REAR CABI."  
⑪ When performing wiring connection between the FRONT CABI and the REAR CABI, connect the 2 Communication Cables to the Connector Panel.



COMMUNICATION CABLE (2)

PHOTO 18. 2 e

- ⑫ Attach the Floor Lid.  
⑬ Install the machines side by side.

### 18 - 3 SETTING FOR COMMUNICATION PLAY



During communication play, if the test mode is not finished within 3 minutes on all the linked machines, the NETWORK CHECK cannot be performed, causing NETWORK ERROR.

Change the game setting for each seat in a manner so as to meet communication play. If the setting is not correct, communication play cannot be played.

SYSTEM ASSIGNMENTS

CABINET TYPE	1PLAYER
ADVERTISE SOUND	ON
MONITOR TYPE	HORIZONTAL
DISPLAY TYPE	AUTOSCAN
SERVICE TYPE	COMMON
COMMUNICATION MODE	MASTER
> EXIT	

SELECT WITH SERVICE BUTTON  
AND  
PRESS TEST BUTTON

#### MASTER

GAME ASSIGNMENTS

DEFAULT VIEW	POD
DIFFICULTY	NORMAL
URL	ON
SEAT NUMBER	1
> EXIT	

SELECT WITH SERVICE BUTTON  
AND  
PRESS TEST BUTTON

#### SLAVE

GAME ASSIGNMENTS

SEAT NUMBER	4
> EXIT	

SELECT WITH SERVICE BUTTON  
AND  
PRESS TEST BUTTON

## SETTING FOR COMMUNICATION PLAY

- ① Turn the linked machines' power on.
- ② Cause all of the machines to enter the test mode.
- ③ Select the SYSTEM ASSIGNMENTS.
- ④ Perform the COMMUNICATION MODE setting in the SYSTEM ASSIGNMENTS screen. Set one of the machines to MASTER and all others to SLAVE. Set to RELAY for exclusive use of LIVE Monitor.
- ⑤ Perform the SEAT NO setting in the GAME ASSIGNMENTS screen. Set the machines sequentially to No.1, No.2, No.3, and so on as applicable starting from the extreme left facing the monitor's front side.
- ⑥ Cause all of the machines to exit from the test mode. After the test mode, the screens proceed to and display the NETWORK CHECK.
- ⑦ If the ADVERTISE screen is displayed after the NETWORK CHECK has been finished, the communication setting is satisfactory. If the same number is set for 2 or more machines, the screen displays an error and keeps displaying the NETWORK CHECK. Normally the NETWORK CHECK takes less than one minute. If the screen does not proceed from the NETWORK CHECK screen, some sorts of errors such as incorrect setting, or incorrect connection or malfunctioning of the communication cable can be considered.

### 18 - 4 CAUTIONS TO BE HEEDED DURING COMMUNICATION PLAY



IMPORTANT

- For communication play, perform the setting for the advertise sound and setting in the GAME ASSIGNMENTS on the MASTER seat. All other machine's settings will compulsorily be same as those of the MASTER unit.
- Selecting the hidden vehicles depends on the MASTER unit. All other units can also select the vehicles that can be selected by the MASTER unit. On the other hand, during communication play all other units cannot select the vehicle, even if selectable, which cannot be selected by the MASTER unit.
- If the same number is set for 2 or more machines, the screen keeps displaying the NETWORK CHECK after having displayed an error message.
- During communication play, if communication is interrupted due to some cause, the game is discontinued and the NETWORK CHECK screen is displayed.
- If one of the linked machines enters the test mode, all others display the NETWORK CHECK screen.

Machine's operation when linked for communication play alters comparing to that of when independently operated. Be careful of this point.

As per the above, some Game Assignments are set by the MASTER unit. Even if the SLAVE machines change the setting, the setting will not be effective for the game. When one of the linked machines enters the test mode, all others display the NETWORK CHECK screen. Therefore, be sure not to enter the test mode if any one of the machines is in play.

# 19. PARTS LIST

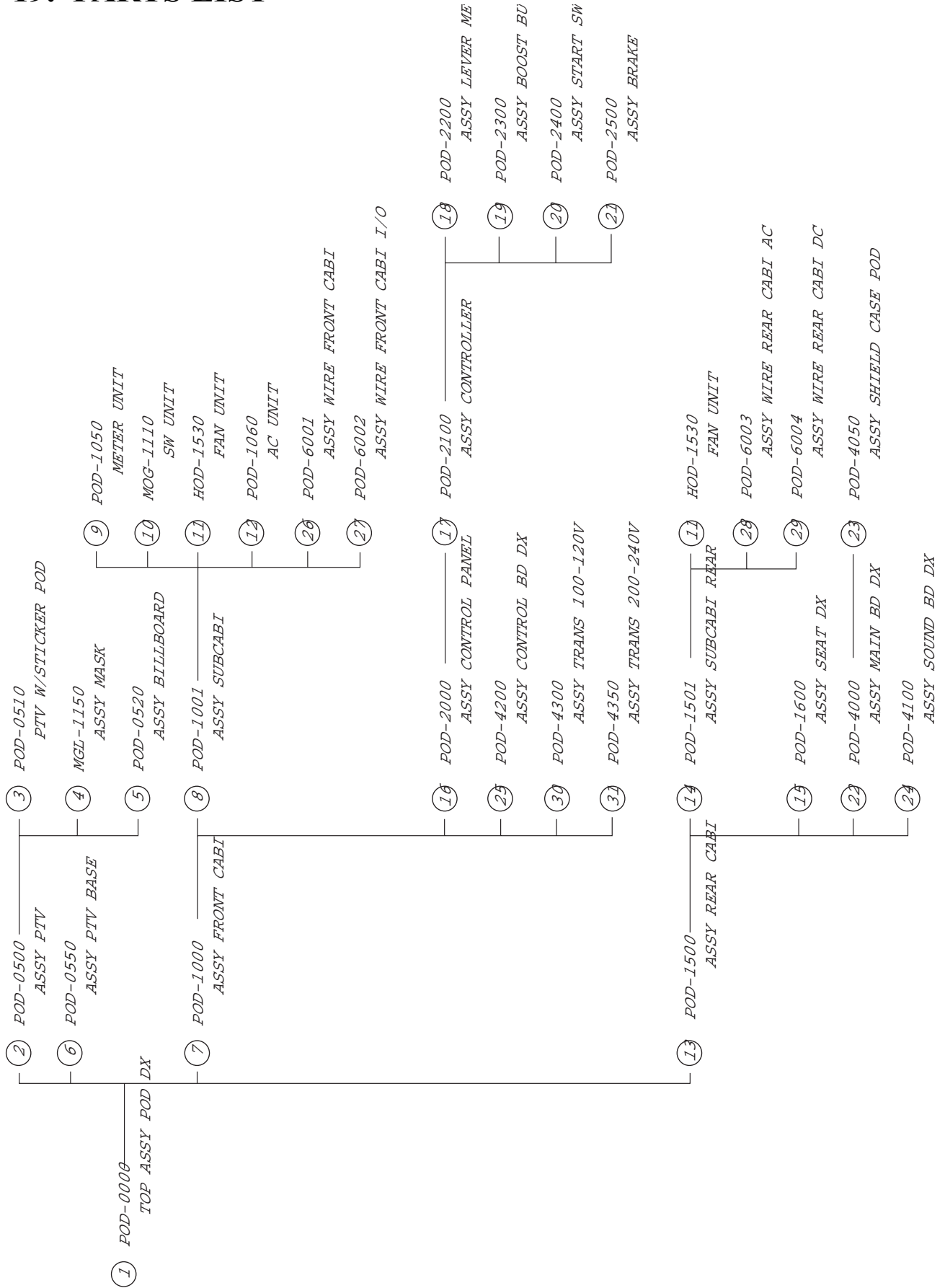



① TOP ASSY POD DX

(D-1/2)

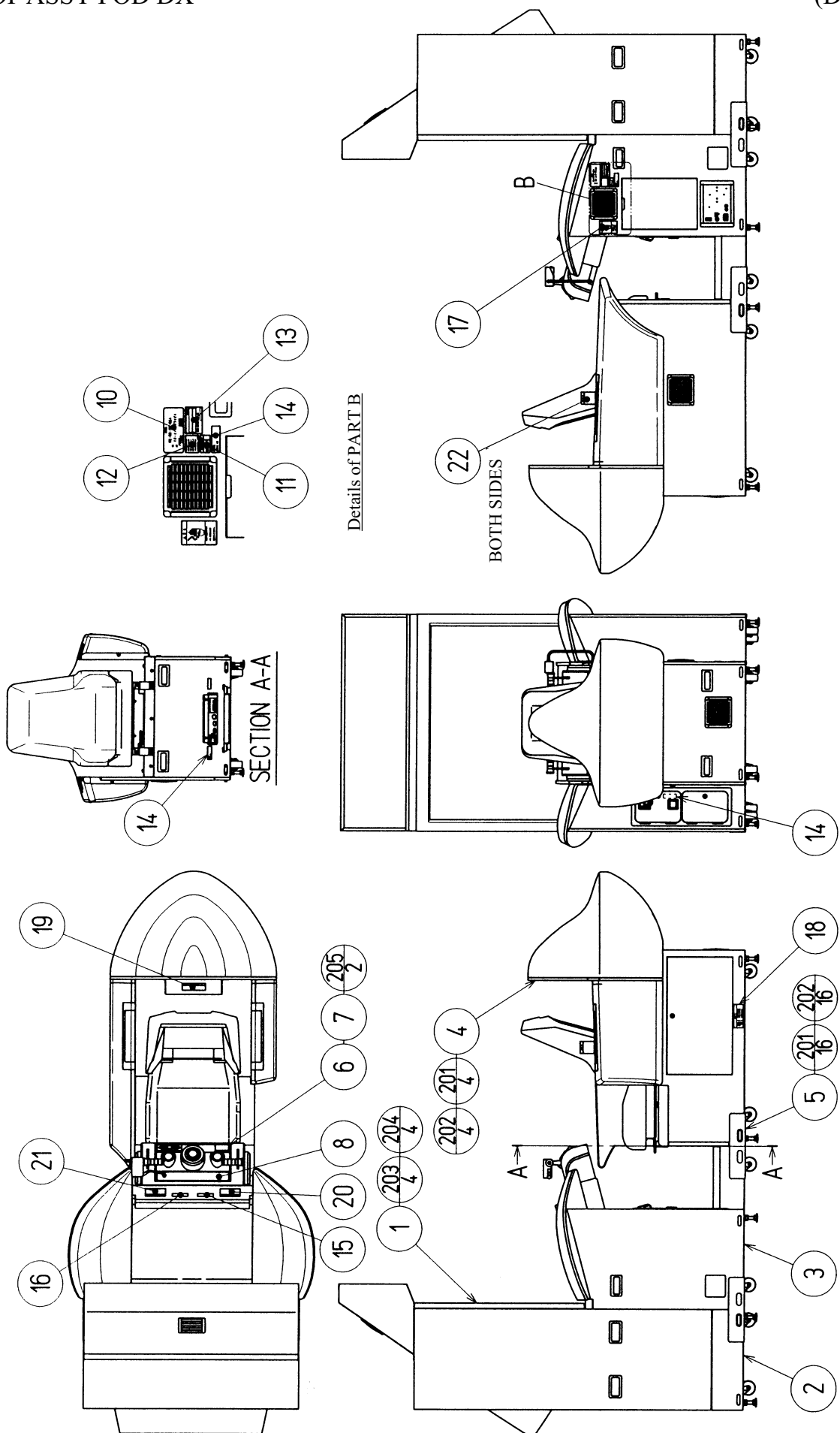

① TOP ASSY POD DX

(D-2/2)

ITEM NO.	PART NO.	DESCRIPTION	NOTE
1	POD-0500	ASSY PTV	
2	POD-0550	ASSY PTV BASE	
3	POD-1000	ASSY FRONT CABI	
4	POD-1500	ASSY REAR CABI	
5	POD-0001	JOINT BRKT	
6	POD-0002	DENOMI PLATE	
7	421-7308~	DENOMINATION SHEET 1GAME ~	
8	POD-0003-01	STICKER INSTR POD ENG	
9	SGM-4357	POLY COVER 1600 X 1300 X 1050	
17	440-WS0002XEG	STICKER W POWER OFF ENG	
18	440-WS0033XEG	STICKER W BD POWER OFF ENG	
19	440-CS0180-EG	STICKER C KEEP OUT ENG	
20	440-CS0186-EG	STICKER C EPILEPSY 40 ENG	
21	440-WS0211-EG	STICKER W DO NOT TOUCH ENG	
22	440-CS0212-EG	STICKER C SEAT ENG	
23	421-8479-01	STICKER INSTR SUNLIGHT ENG	
201	030-000835-SB	HEX BLT BLK W/S M8 X 35	
202	068-852216-0B	FLT WSHR BLK 8.5-22 X 1.6	
203	000-T00525-0B	M SCR TH BLK M5 X 25	
204	068-552016-0B	FLT WSHR BLK 5.5-20 X 1.6	
205	000-T00412-0B	M SCR TH BLK M4 X 12	
401	601-6604-70	CARTON BOX 70	
402	SGM-2675	POLYETHYLENE BAG, 240 X 370	
403	420-6575-01	OWNERS MNL POD DX ENG	
404	600-6664-02	WIRE HARN EARTH W/LUG M6 NOT USED	TAIWAN OTHERS
405	390-5160	LAMP WG B TYPE 6V 3W (C2R)	
406	600-7228	AC CABLE CONNECT TYPE 15A	1 2 3 TAIWAN
	600-6729	AC CABLE CONNECT TYPE 15A	
	600-6618	AC CABLE CONNECT TYPE FOR EXP	OTHERS
	600-6619	AC CABLE CONNECT TYPE FOR UK	HONG KONG
	600-6695	AC CABLE CONNECT TYPE USA 15A	USA
407	SGM-4111	KEY BAG (SGB-1035X)	
408	220-5576	KEY MASTER FOR 220-5575	
409	280-5009-01	CORD CLAMP 21	
411	POD-0004	OPT CONN BRKT	
412	310-5285-290100	FLEX TUBE 29-0100CM	
413	310-5286-29	CONN 29	
414	220-5484	VOL CONT B-5K OHM	
	220-5373	VOL CONT B-5K	
415	540-0009-01	WRENCH FOR TAMP SCR M8	
416	600-6275-0700	ASSY FIBER CABLE 5 700CM	
417	090-0074	STATICIDE (300ML)	
/	POD-0524	POP HOLDER	
/	POD-0525	POP SH POD	
/	000-T00408-0B	M SCR TH BLK M4 X 8	
/	GPD-0002X	SHIPPING BRKT	
/	421-8740	CAUTION INSTR COP U/R	
/	421-6690-03	STICKER 220V	AC 220V AREA
/	421-6690-05	STICKER 240V	AC 240V AREA
/	421-6690-06	STICKER 110V	AC 110V AREA
/	421-6690-04	STICKER 230V	AC 230V AREA
/	421-6690-01	STICKER 120V	AC 120V AREA
/	421-6119-91	STICKER FCC	1 2 3 USA
/	421-6120-92	STICKER SEGA USA	

② ASSY PTV (POD-0500)

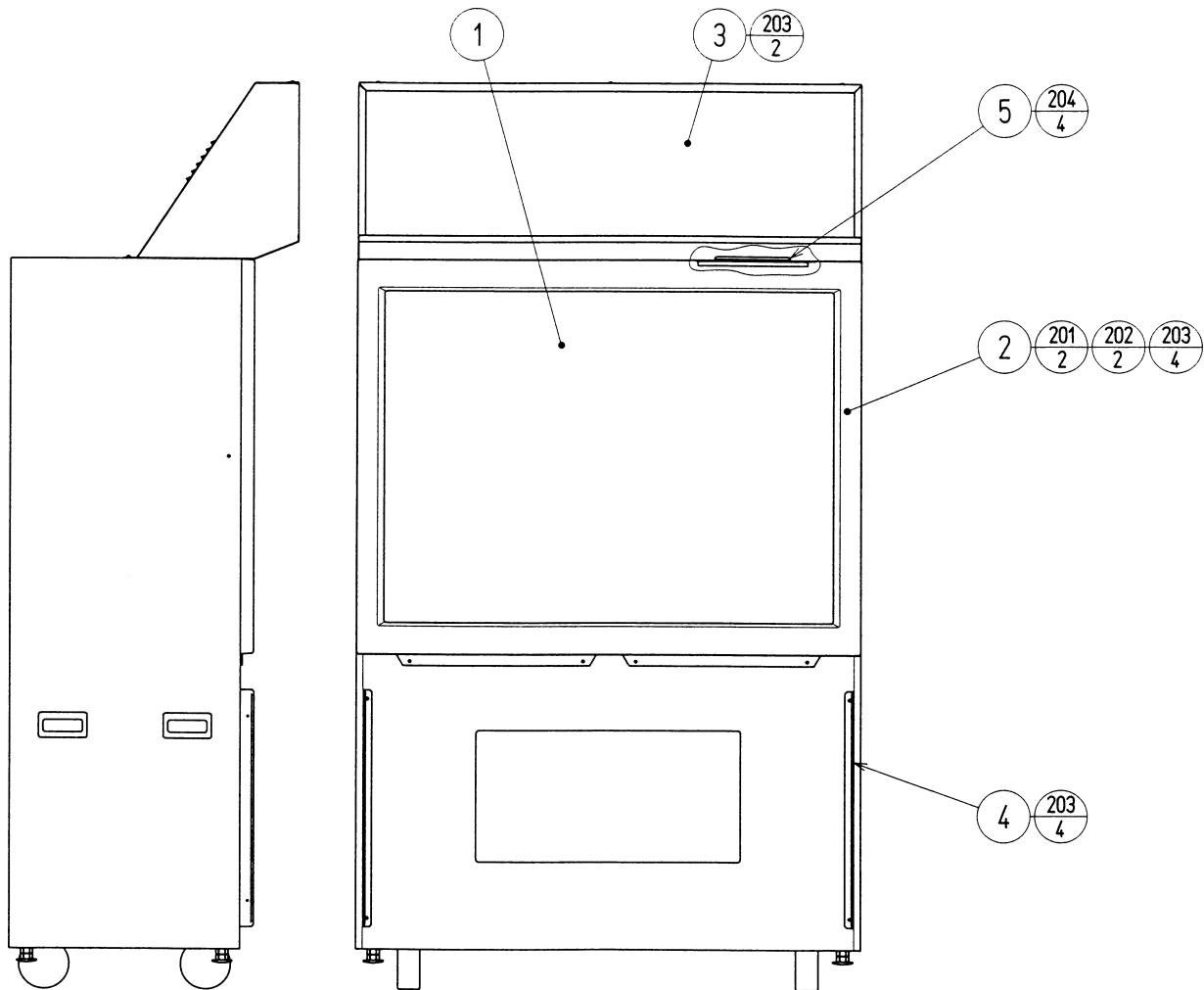

ITEM NO.	PART NO.	DESCRIPTION	NOTE
1	POD-0510	PTV W/STICKER POD	
2	MGL-1150	ASSY MASK	
3	POD-0520	ASSY BILLBOARD	
4	HOD-1101	PTV HOLDER	
5	RAL-0501	MASK HOLDER	
201	000-T00525-0B	M SCR TH BLK M5 X 25	
202	068-552016-0B	FLT WSHR BLK 5.5-20 X 1.6	
203	000-P00520-WB	M SCR PH W/FS BLK M5 X 20	
204	000-F00412	M SCR FH M4 X 12	

③ ASSY W/STICKER POD (POD-0510)

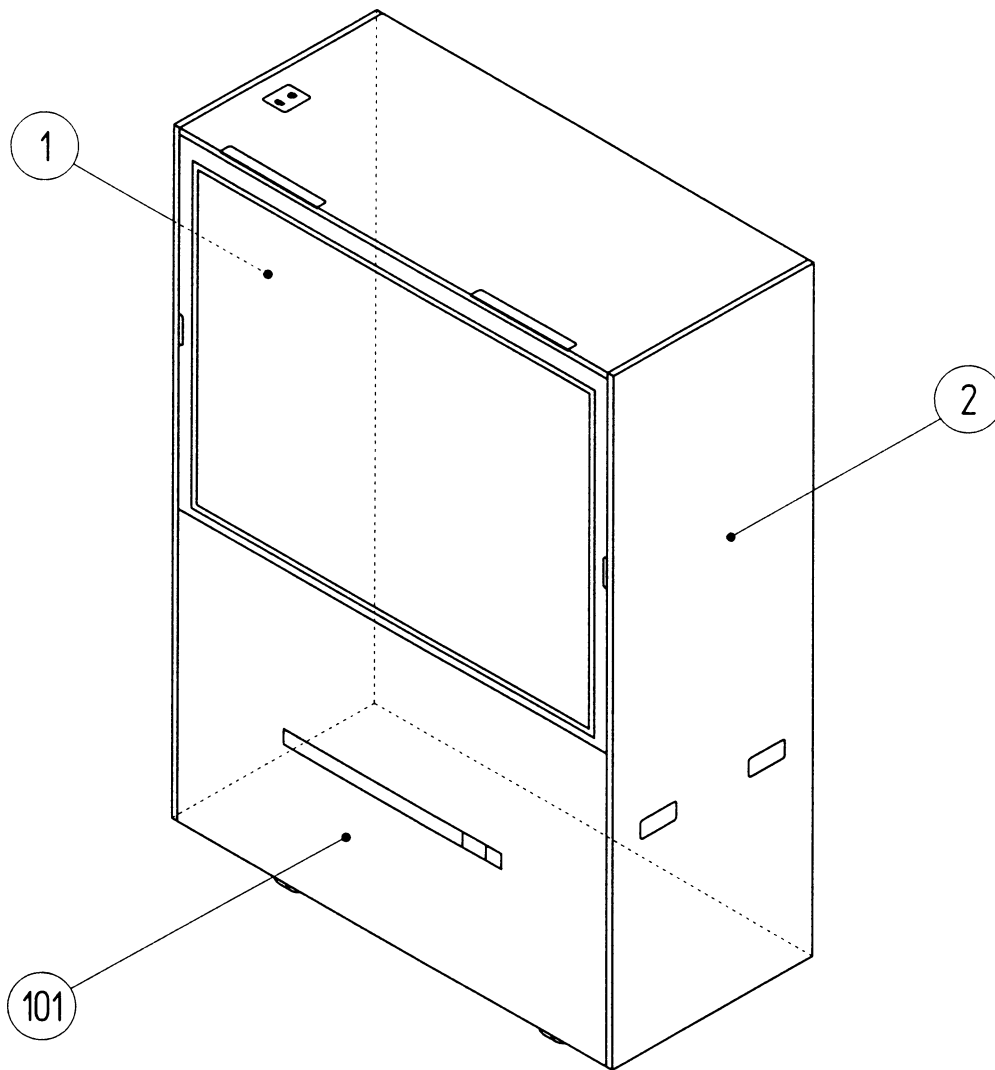

ITEM NO.	PART NO.	DESCRIPTION	NOTE
1	POD-0511	STICKER PTV SIDE L	
2	POD-0512	STICKER PTV SIDE R	
101	200-5788-31	PROJECTION DSPL T 50TYPE 31K	

④ ASSY MASK (MGL-1150)

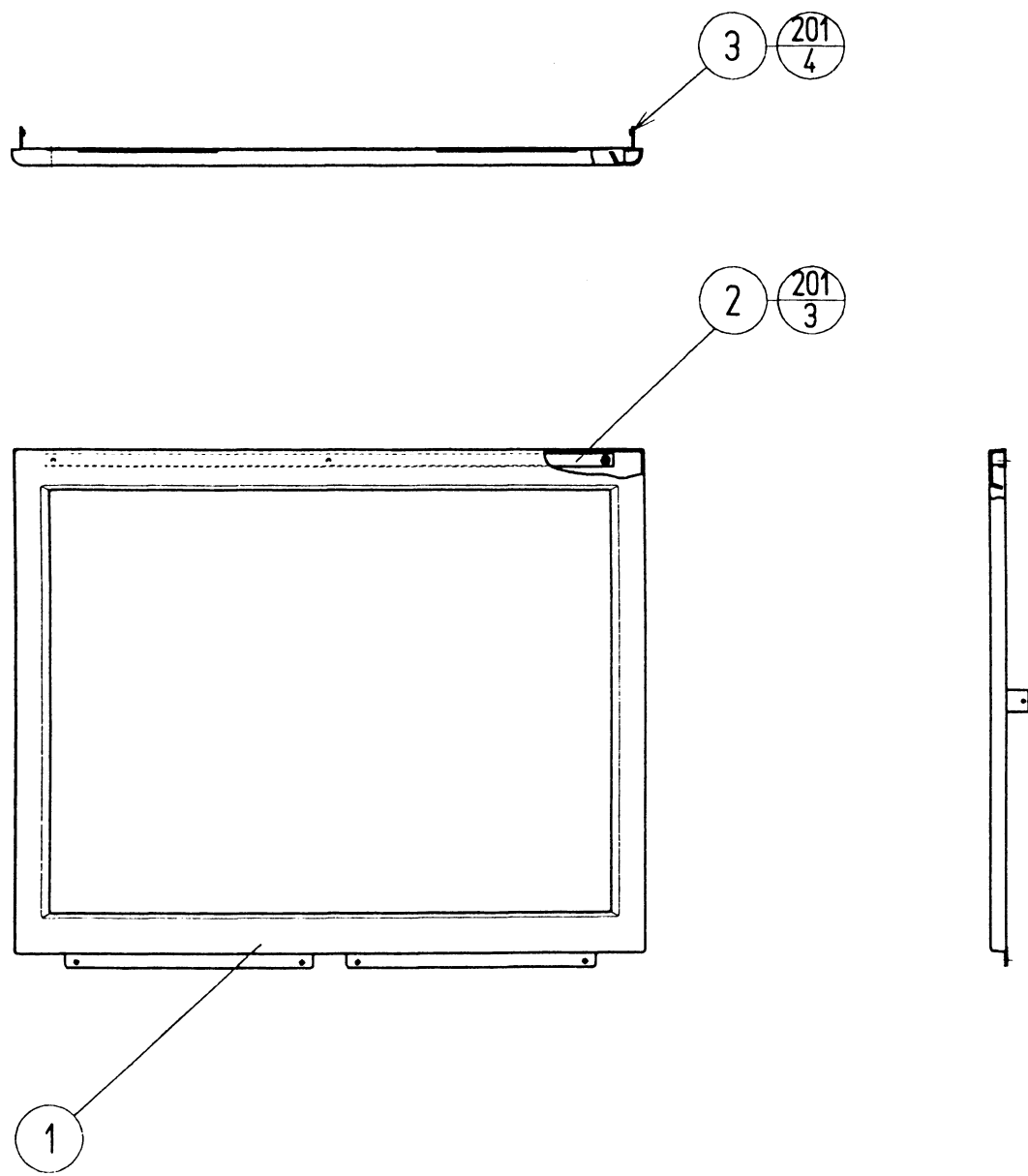

ITEM NO.	PART NO.	DESCRIPTION	NOTE
1	MGL-1102	TV MASK	
2	MGL-1151	SLIT PLATE	
3	MGL-1152	MASK SIDE HOLDER	
201	012-F00408-0B	TAP SCR #2 FH BLK 4 X 8	
202	000-F00410	M SCR FH M4 X 10	

5 ASSY BILLBOARD (POD-0520)

(D-1/2)

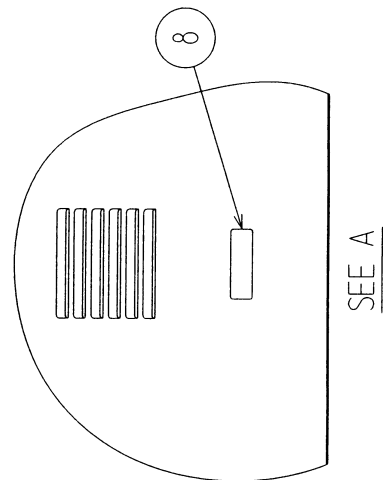
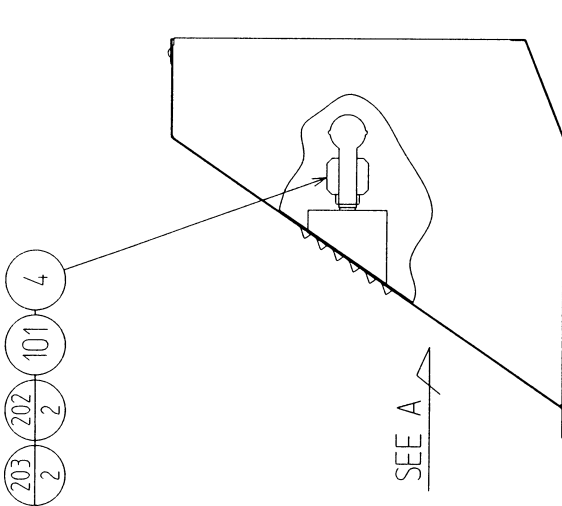
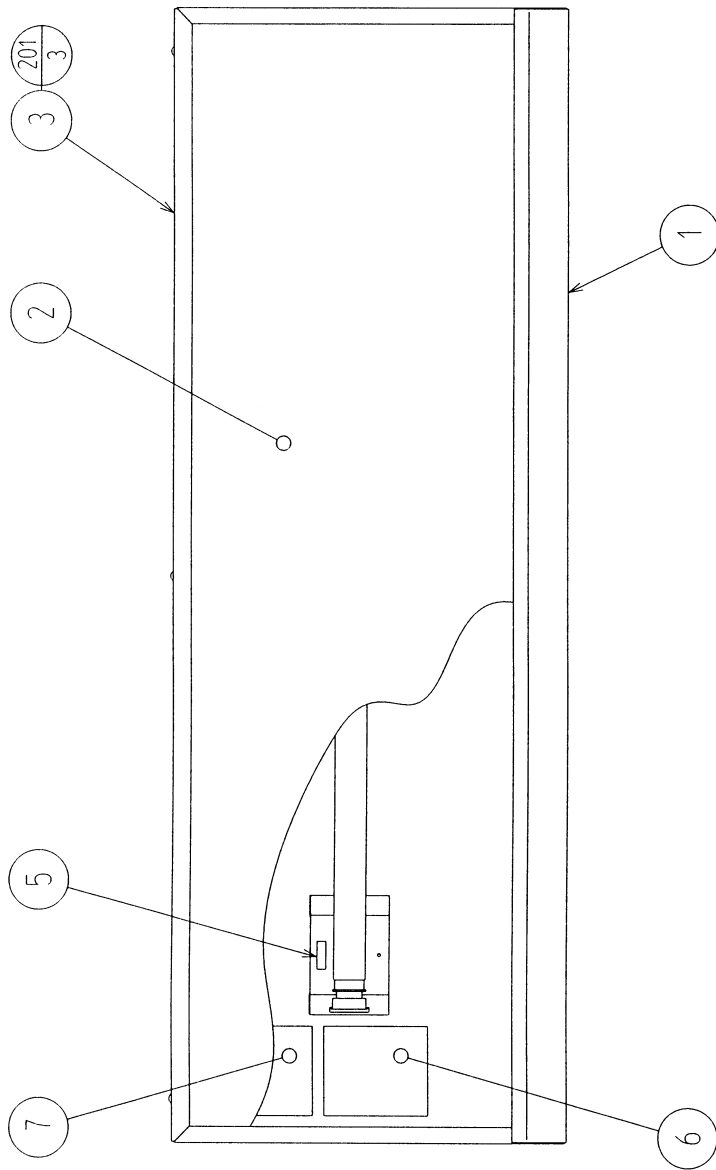

⑤ ASSY BILLBOARD (POD-0520)

(D-2/2)

ITEM NO.	PART NO.	DESCRIPTION	NOTE
1	POD-0521	BILLBOARD BOX	
2	POD-0522	BILLBOARD PLATE POD DX	
3	POD-0523	BILLBOARD SASH	
4	253-5457	FL HOLDER Locally supplied.	OTHERS USA
5	421-7501-18	STICKER FL32W Locally supplied.	OTHERS USA
6	440-WS0002XEG	STICKER W POWER OFF ENG	
7	440-WS0012XEG	STICKER W HIGH TEMP ENG	
101	390-6659-32EX	ASSY FL32W EX W/CONN HIGH S CE Locally supplied.	OTHERS USA
102	280-5275-SR10	CORD CLAMP SR10	
201	000-T00408-0B	M SCR TH BLK M4 X 8	
202	000-P00430-S	M SCR PH W/S M4 X 30 Locally supplied.	OTHERS USA
203	068-441616	FLT WSHR 4.4-16 X 1.6 Locally supplied.	OTHERS USA
301	600-7117-010	WIRE HARN FL	

⑥ ASSY PTV BASE (POD-0550)

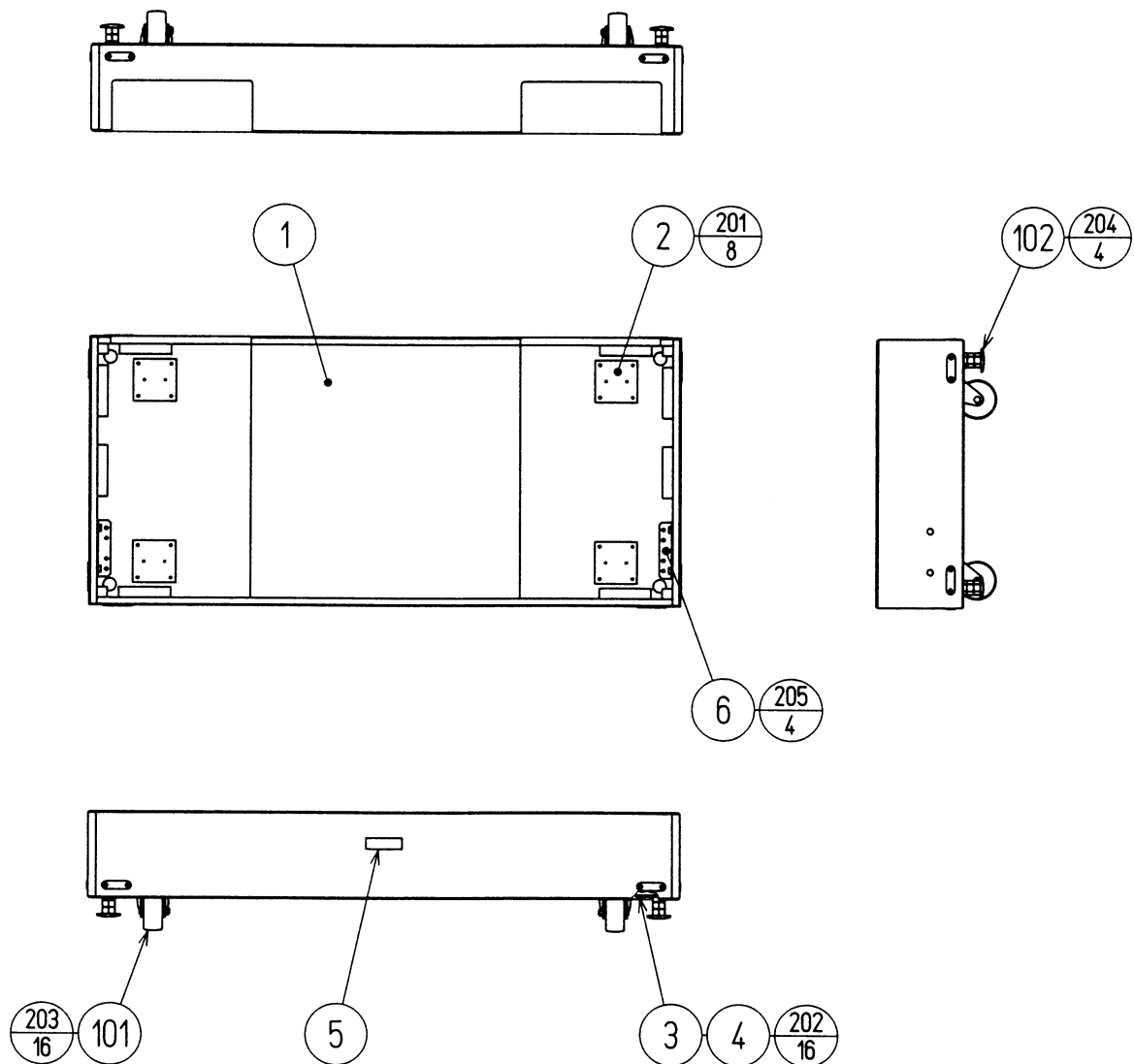

ITEM NO.	PART NO.	DESCRIPTION	NOTE
1	POD-0551	PTV BASE	
2	SCR-1008	NUT PLATE FOR CASTER	
3	ARC-1006	LEG BRACKET	
4	117-5233	PLATE LEG BRACKET BLACK	
6	POD-1008	NUT BRKT	
101	601-9377 601-6224	CASTER FAI=75 CASTER 75	
102	601-5699X	LEG ADJUSTER BOLT M16 X 75	
201	011-T03512	TAP SCR TH 3.5 X 12	
202	030-000625-SB	HEX BLT W/S BLK M6 X 25	
203	030-000625-W	HEX BLT W/FS M6 X 25	
204	050-H01600-0B	HEX NUT BLK M16	
205	000-P00520-W	M SCR PH W/FS M5 X 20	



7 ASSY FRONT CABI (POD-1000)

(D-1/2)

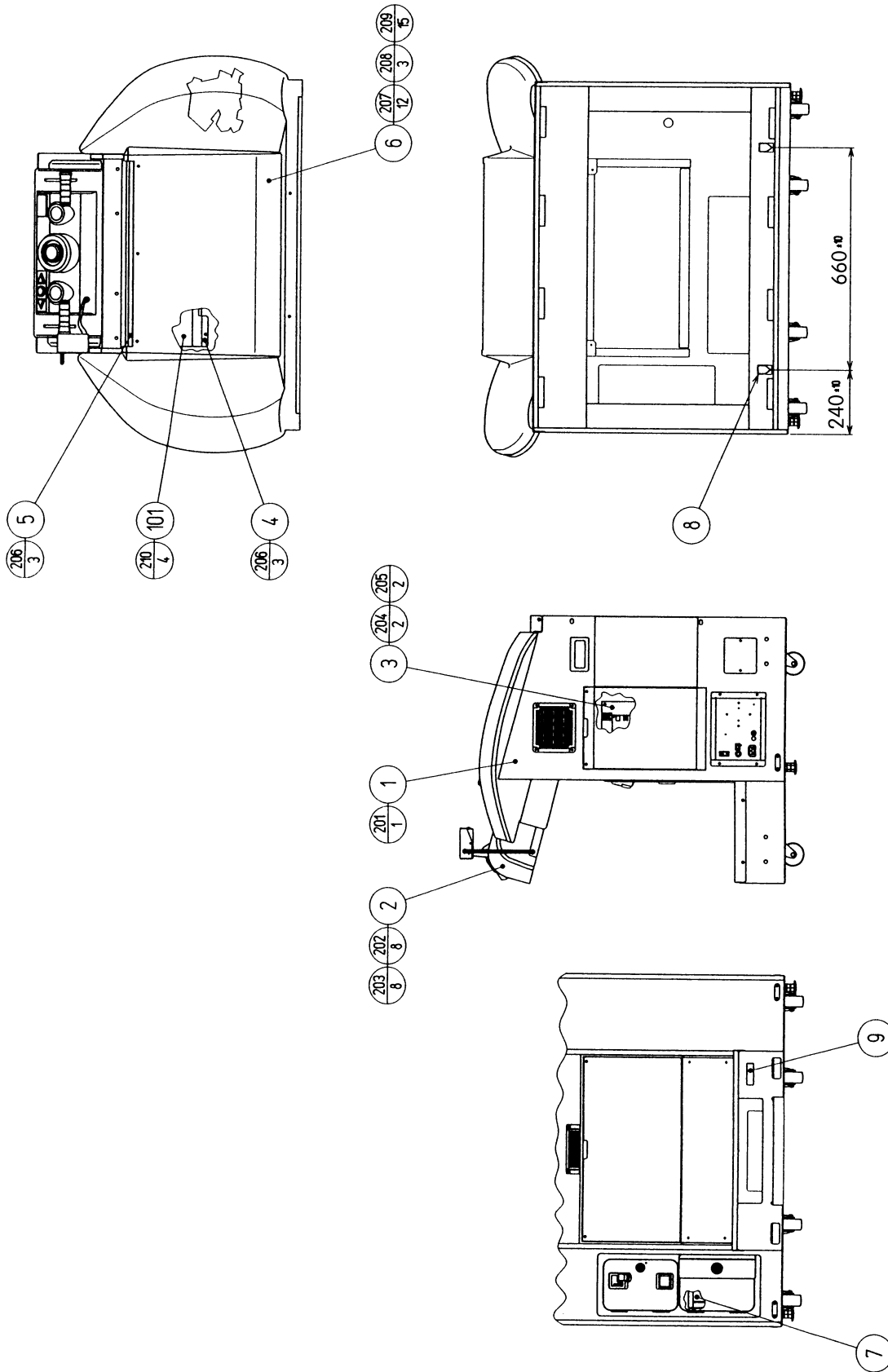

⑦ ASSY FRONT CABI (POD-1000)

(D-2/2)

ITEM NO.	PART NO.	DESCRIPTION	NOTE
1	POD-1001	ASSY SUBCABI FRONT	
2	POD-2000	ASSY CONTROL PANEL	
3	POD-4200	ASSY CONTROL BD DX	
4	POD-1018	SPEAKER HOLDER	
5	POD-1019	SPEAKER BRKT	
6	POD-1020	FRONT COVER	
7	253-5417	CASH BOX LOW	
8	421-8885	STICKER CAUTION FORK	
101	130-5156	SPEAKER BOX 8 OHM 20W	
201	000-T00430-0B	M SCR TH BLK M4 X 30	
202	008-B00830-0B	TMP PRF SCR BH BLK M8 X 30	
203	060-F00800-0B	FLT WSHR BLK M8	
204	000-P00425-S	M SCR PH W/S M4 X 25	
205	068-441616	FLT WSHR 4.4-16 X 1.6	
206	000-P00416-W	M SCR PH W/FS M4 X 16	
207	000-T00420-0C	M SCR TH CRM M4 X 20	
208	000-T00412-0C	M SCR TH CRM M4 X 12	
209	068-441616-0C	FLT WSHR CRM 4.4-16 X 1.6	
210	000-P00512-W	M SCR PH W/FS M5 X 12	
/	030-000635-S	HEX BLT W/S M6 X 35	
/	068-652016	FLT WSHR 6.5-20 X 1.6	
/	POD-4350	ASSY TRANS 200-240V	AC 220 ~ 240V AREA
/	POD-4300	ASSY TRANS 100-120V	AC 110 ~ 120V AREA

8 ASSY SUBCABI FRONT (POD-1001)

(D-1/3)

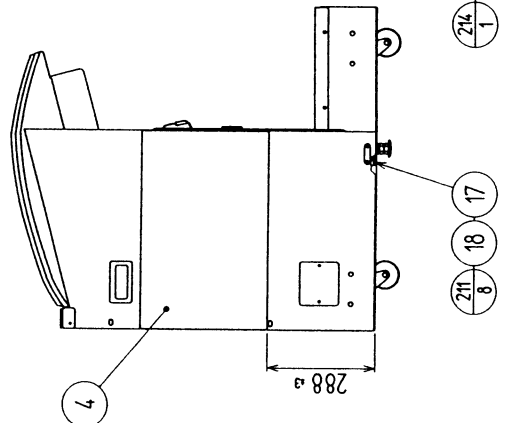
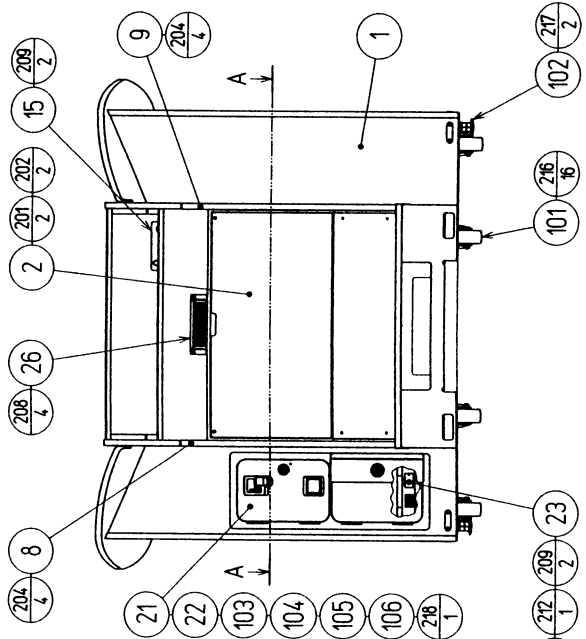
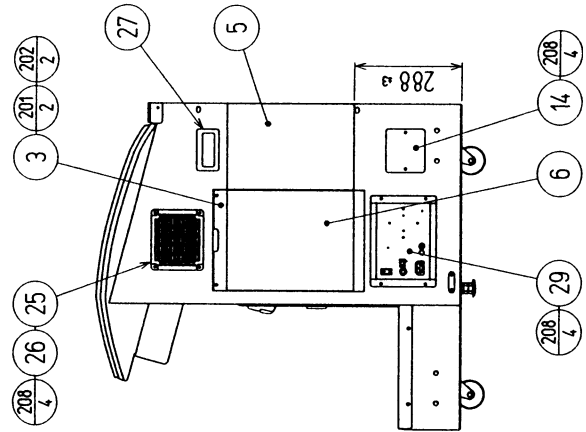
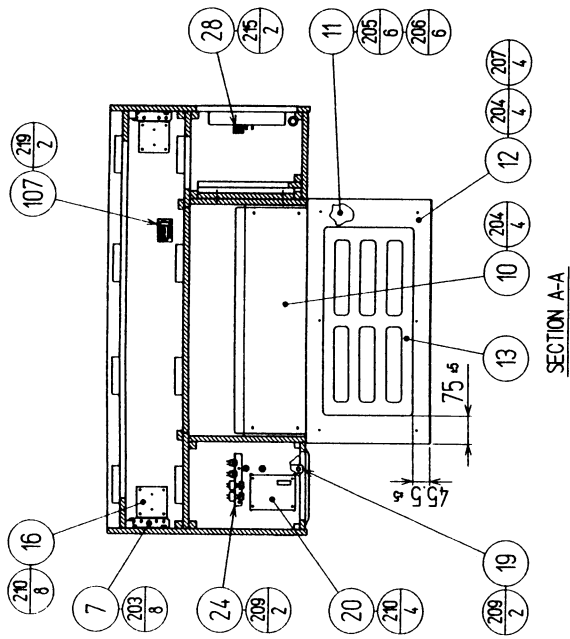

⑧ ASSY SUBCABI FRONT (POD-1001)

(D-2/3)

ITEM NO.	PART NO.	DESCRIPTION	NOTE
1	POD-1002	FRONT CABINET	
2	POD-1003	FRONT LID	
3	POD-1004	SIDE LID	
4	POD-1005	STICKER FRONT L	
5	POD-1006	STICKER FRONT R	
6	POD-1007	STICKER SIDE LID	
7	POD-1008	NUT BRKT	
8	POD-1009	FRONT SASH L	
9	POD-1010	FRONT SASH R	
10	POD-1011	STEP BRKT	
11	POD-1012	FLOOR BOARD	
12	POD-1013	FLOOR BRKT	
13	POD-1014	FLOOR MAT	
14	POD-1015	OPT CONN LID	
15	POD-1016	CONN PLATE	
16	SCR-1008	NUT PLATE FOR CASTER	
17	ARC-1006	LEG BRACKET	
18	117-5233	PLATE LEG BRACKET BLACK	
19	105-5169	LOCK BRACKET W	
20	105-5171	CHUTE PLATE SINGLE	OTHERS
	105-5172	CHUTE PLATE DOUBLE	USA
21	DP-1167	TNG LKG	OTHERS
		Locally supplied.	USA
22	421-7501-02	STICKER 6.3V 0.15A	OTHERS
		Locally supplied.	USA
23	POD-1050	METER UNIT	
24	MOG-1110	SW UNIT	
25	HOD-1530	FAN UNIT	
26	253-5460-01	AIR VENT BLACK	
27	253-5396-91	CABINET HANDLE	
28	117-5402-06	EARTH TERMINAL PLATE 6P	
29	POD-1060	AC UNIT	
101	601-9377	CASTER FAI=75	
	601-6224	CASTER 75	
102	601-5699X	LEG ADJUSTER BOLT M16 X 75	
103	220-5237-92~~	ASSY C.C 2DR ~	OTHERS
	220-5482-91~~	ASSY C.C 2DR ~	HONG KONG, KOREA, TAIWAN
		Locally supplied.	USA
104	220-5575	CAM LOCK MASTER W/O KEY	OTHERS
		Locally supplied.	USA
105	220-5574	CAM LOCK W/KEYS	OTHERS
		Locally supplied.	USA
106	310-5029-F20	SUMITUBE F F 20MM	OTHERS
		Locally supplied.	USA
107	838-11856-UL	CONNECT BD UL	
108	280-5277	CORD CLAMP 18	
109	280-5207	HARNESS LUG CC-1005	

⑧ ASSY SUBCABI FRONT (POD-1001)

(D-2/3)

ITEM NO.	PART NO.	DESCRIPTION	NOTE
201	000-T00430-0B	M SCR TH BLK M4 X 30	
202	068-441616-0B	FLT WSHR BLK 4.4-16 X 1.6	
203	000-P00520-W	M SCR PH W/FS M5 X 20	
204	000-T00416-0C	M SCR TH CRM M4 X 16	
205	050-F00400	FLG NUT M4	
206	068-441616	FLT WSHR 4.4-16 X 1.6	
207	068-441616-0C	FLT WSHR CRM 4.4-16 X 1.6	
208	000-T00420-0B	M SCR TH BLK M4 X 20	
209	000-P00420-W	M SCR PH W/FS M4 X 20	
210	011-T03512	TAP SCR TH 3.5 X 12	
211	030-000625-SB	HEX BLT W/S BLK M6 X 25	
212	050-H00400	HEX NUT M4	
213	060-S00400	SPR WSHR M4	
214	060-F00400	FLT WSHR M4	
215	011-F00316	TAP SCR FH 3 X 16	
216	030-000625-W	HEX BLT W/FS M6 X 25	
217	050-H01600-0B	HEX NUT BLK M16	
218	000-P00408-W	M SCR PH W/FS M4 X 8	
219	011-P00325	TAP SCR PH 3 X 25	
301	POD-60071	WIRE HARN AC EXT	
302	POD-60002	WIRE HARN AC EXT	
303	600-6455-02	WIRE HARN C.C DOOR SINGLE Locally supplied.	OTHERS USA
304	POD-6001	ASSY WIRE FRONT CABI	
305	POD-6002	ASSY WIRE FRONT CABI I/O	
306	600-6972-0400	WIRE HARN EARTH ID5 0400MM	

⑨ METER UNIT (POD-1050)

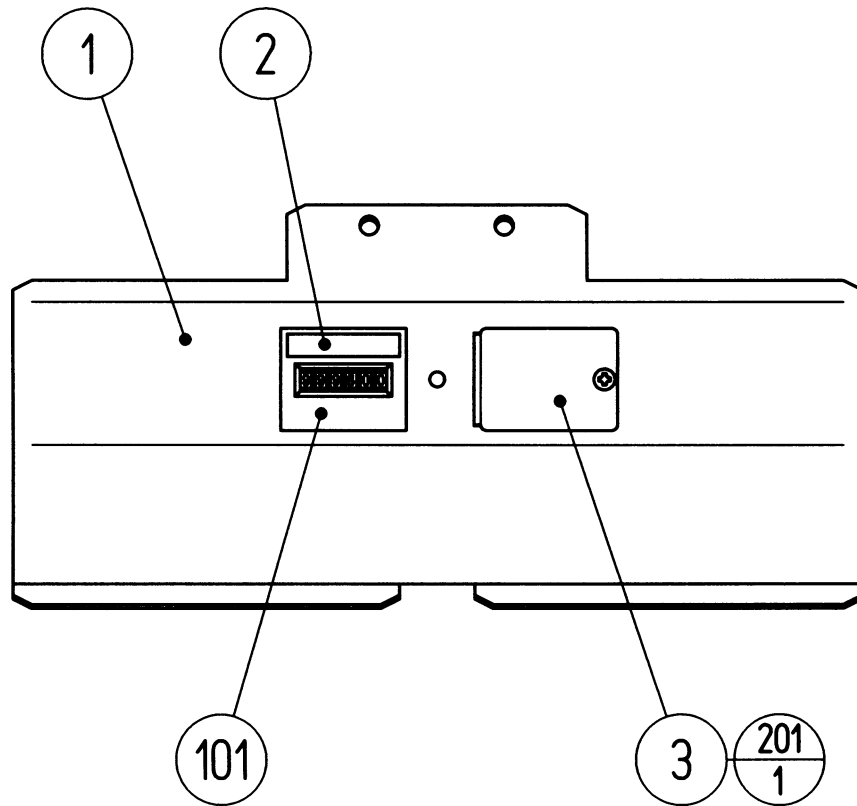

ITEM NO.	PART NO.	DESCRIPTION	NOTE
1	POD-1051	METER BRKT	
2	421-9168-01	STICKER COIN METER	
3	HOT-1007	LID COIN CNTR Locally supplied.	OTHERS USA
101	220-5643-01 220-5617-01	MAG CNTR DC5V 6P WH MZ-674-D04 MAG CNTR DC5V W/CONN 6P WH	
201	000-P00308-W	M SCR PH W/FS M3 X 8 Locally supplied.	OTHERS USA
/	220-5617-02	MAG CNTR DC5V W/CONN 6P YE	USA
/	220-5643-02	MAG CNTR DC5V 6P YE MZ-674-D05	USA

⑩ SW UNIT (MOG-1110)

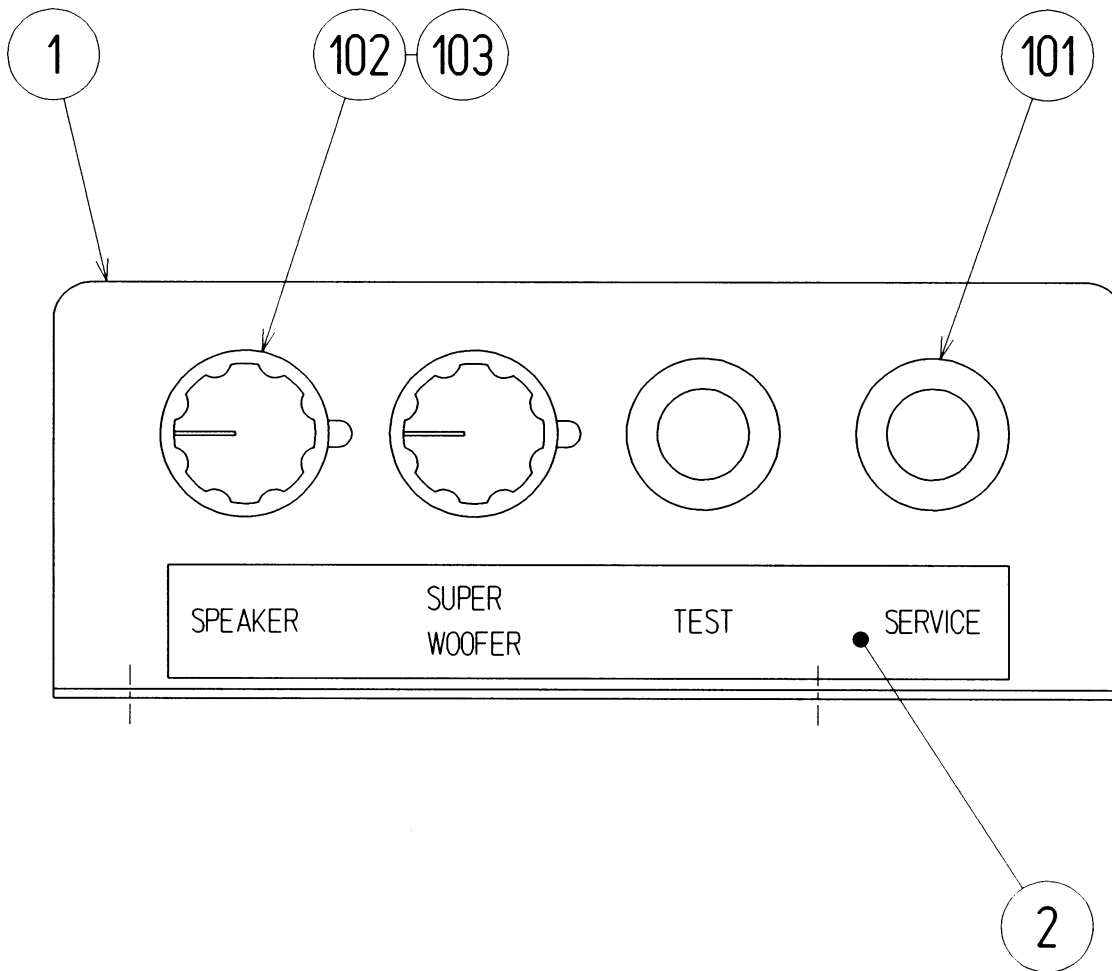

ITEM NO.	PART NO.	DESCRIPTION	NOTE
1	INY-1181	SW BRKT	
2	421-8911	STICKER SW UNIT	
101	509-5028	SW PB 1M	
102	220-5179	VOL CONT B-5K OHM	
103	601-0042	KNOB 22 MM	
104	310-5029-D20	SUMITUBE F D 20 MM	
105	601-0460	PLASTIC TIE BELT 100 MM	
301	MOG-60034	WIRE HARN SW UNIT	

⑪ FUN UNIT (HOD-1530)

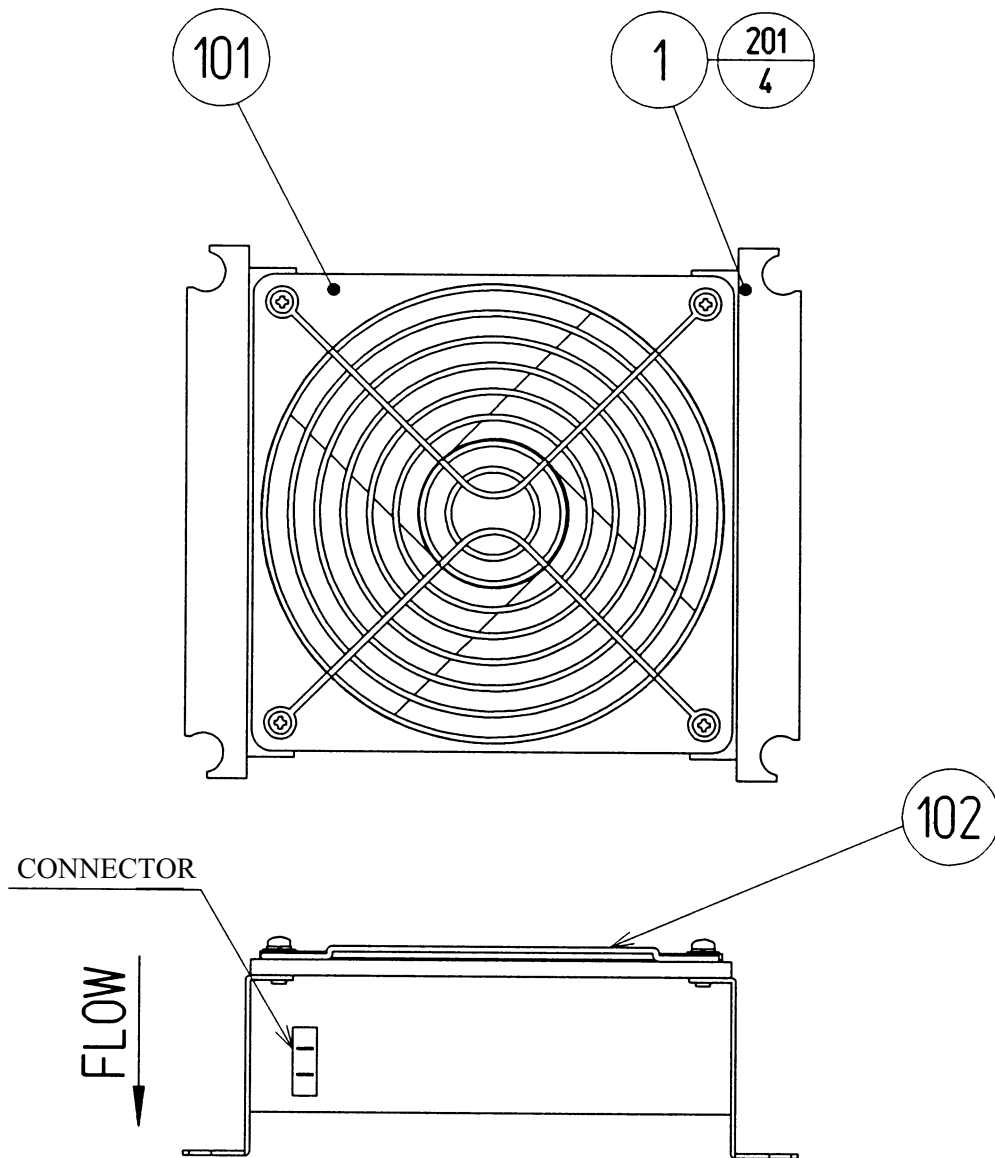

ITEM NO.	PART NO.	DESCRIPTION	NOTE
1	105-5340-01	FAN BRKT LONG	
101	260-0011-02	AXIAL FLOW FAN AC100V 50-60HZ	
102	601-8543	FAN GUARD	
103	280-5275-SR10	CORD CLAMP SR10	
201	000-P00312-W	M SCR PH W/FS M3 X 12	



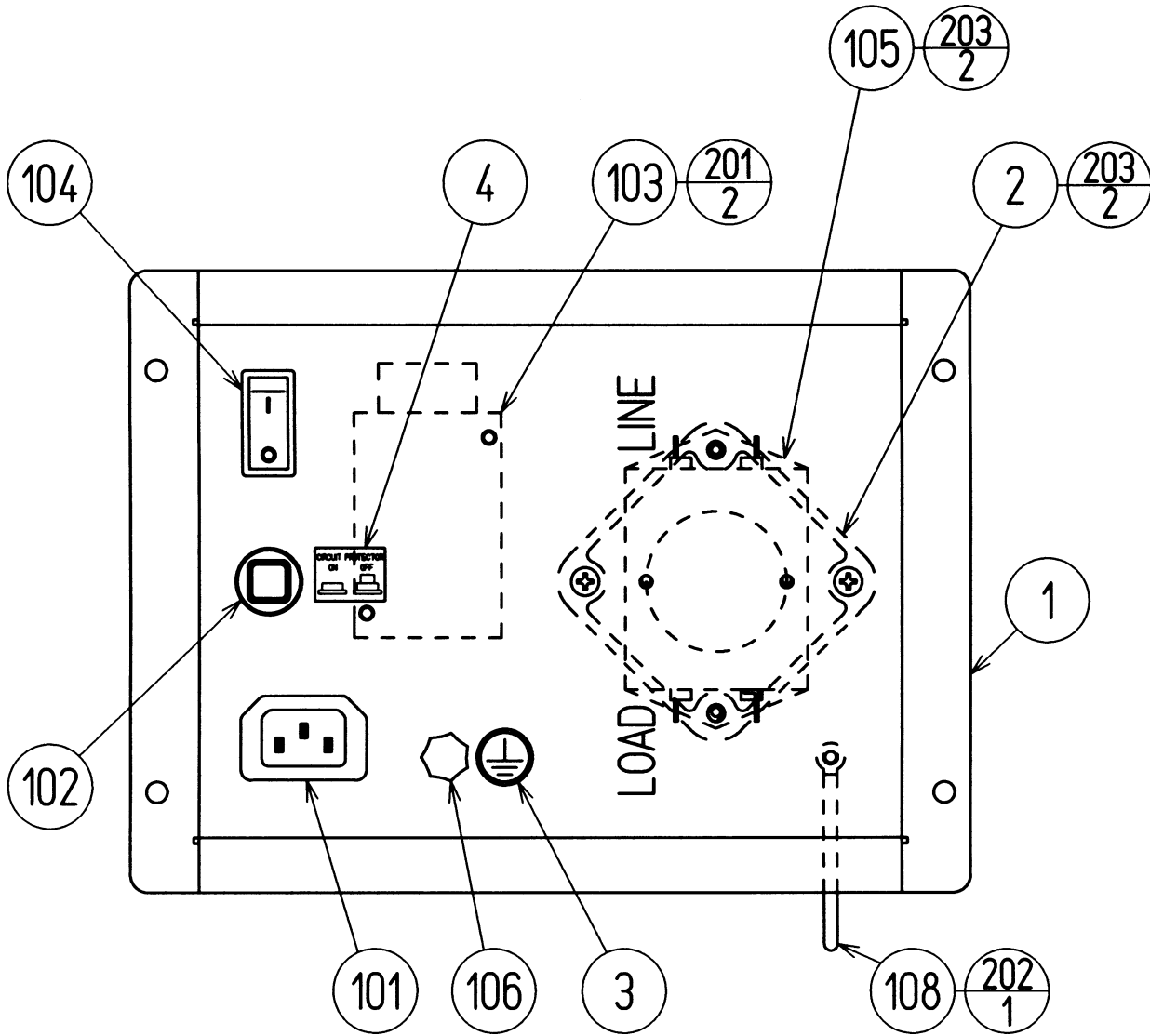

⑫ AC UNIT (POD-1060)

(D-2/2)

ITEM NO.	PART NO.	DESCRIPTION	NOTE
1	JBA-1031	AC BRKT	
2	DYN-0402	NOISE FILTER BASE	
3	421-8202	STICKER EARTH MARK	
4	421-7468-01	STICKER C.P W/PIC	
101	214-0202	AC INLET PANEL TYPE	
102	512-5046-8000	C.P 8000MA CE UL	AC 110V AREA
	512-5046-5000	C.P 5000MA CE UL	AC 220 ~ 240V AREA
103	450-5126	MAGNET CONTACT S-NIOCX	TAIWAN
	450-5134	MAGNET CONTACT S-NIOCX AC 230V	OTHERS
	450-5133	MAGNET CONTACT S-NIOCX AC 200V	KOREA
	450-5135	MAGNET CONTACT S-NIOCX AC 120V	USA
104	509-5453-91-V-B	SW ROCKER J8 V-B	
105	270-5115	NOISE FILTER 15A GT-215J	
106	280-0417	TERMINAL BINDING POST BLACK	TAIWAN
		NOT USED	OTHERS
107	310-5029-K20	SUMITUBE F K 20MM	
108	280-0419	HARNESS LUG	
109	601-0460	PLASTIC TIE BELT 100 MM	
201	000-P00416-WB	M SCR PH W/FS BLK M4 X 16	
202	000-P00408-WB	M SCR PH W/FS BLK M4 X 8	
203	012-P00408	TAP SCR #2 PH 4 X 8	
204	060-F00400	FLT WSHR M4	
205	060-S00400	SPR WSHR M4	
206	050-H00400	HEX NUT M4	
301	JBA-60001	WIRE HARN AC UNIT IN	
302	JBA-60002	WIRE HARN MAIN SW	
303	JBA-60003	WIRE HARN M.CONTACT & N.FILTER	
304	POD-60061	WIRE HARN AC UNIT OUT	
305	JBA-60037	WIRE HARN EARTH INLET	
306	600-6972-0250	WIRE HARN EARTH ID5 0250MM	

13 ASSY REAR CABI (POD-1500)

(D-1/2)

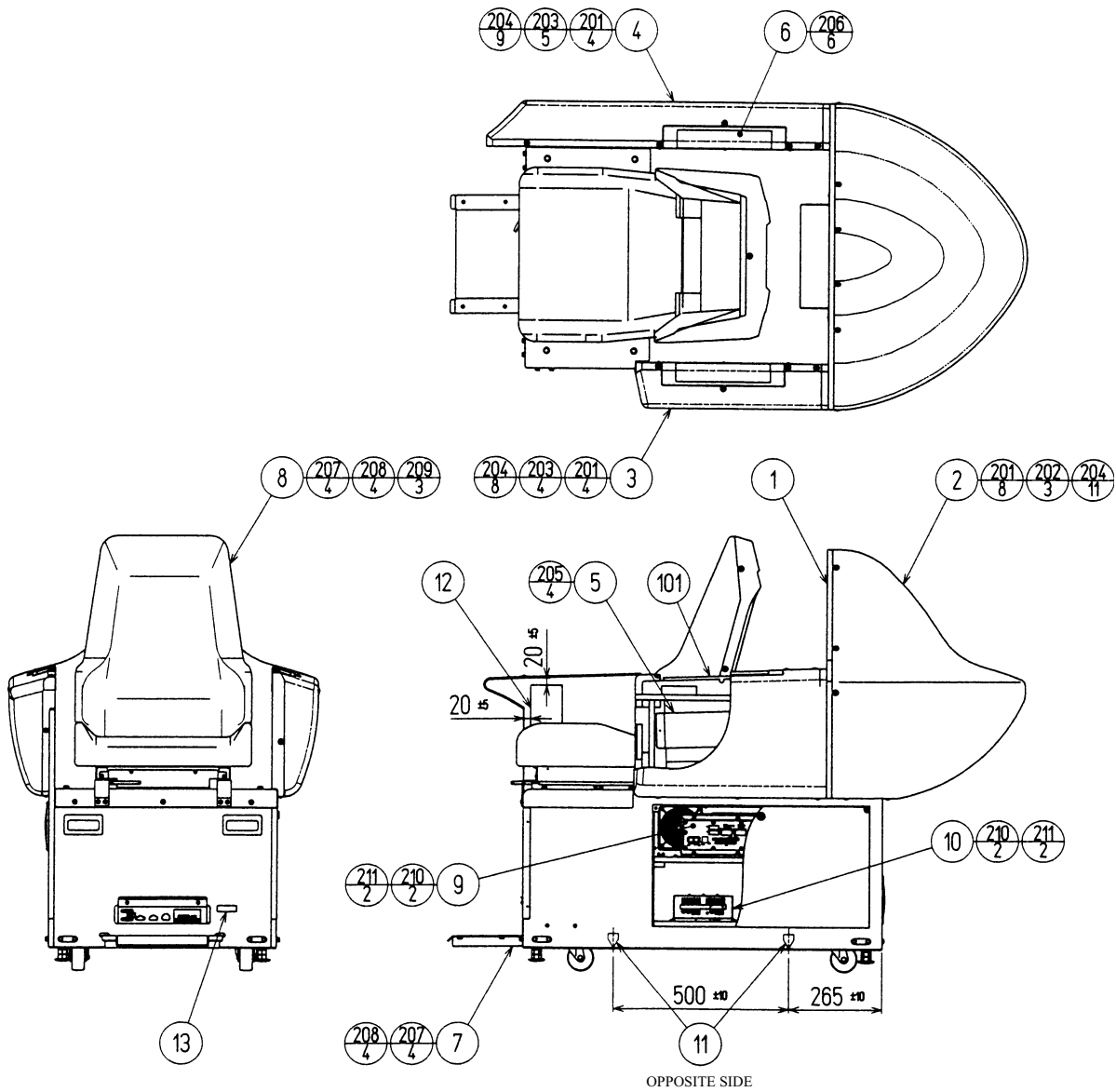

⑬ ASSY REAR CABI (POD-1500)

(D-2/2)

ITEM NO.	PART NO.	DESCRIPTION	NOTE
1	POD-1501	ASSY SUBCABI REAR	
2	POD-1504	BACK COVER	
3	POD-1505	SIDE COVER L	
4	POD-1506	SIDE COVER R	
5	POD-1509	SP BELT	
6	POD-1510	SP NET	
7	POD-1513	JOINT BRKT CENTER	
8	POD-1600	ASSY SEAT DX	
9	POD-4000	ASSY MAIN BD DX	
10	POD-4100	ASSY SOUND BD DX	
11	421-8885	STICKER CAUTION FORK	
12	421-11277-01	STICKER SEAT LEVER ENG	
101	130-5156	SPEAKER BOX 8 OHM 20W	
201	000-T00420-0C	M SCR TH CRM M4 X 20	
202	000-T00416-0C	M SCR TH CRM M4 X 16	
203	000-T00412-0C	M SCR TH CRM M4 X 12	
204	068-441616-0C	FLT WSHR CRM 4.4-16 X 1.6	
205	000-T00420-0B	M SCR TH BLK M4 X 20	
206	000-T00416-0B	M SCR TH BLK M4 X 16	
207	030-000835-SB	HEX BLT BLK W/S M8 X 35	
208	068-852216-0B	FLT WSHR BLK 8.5-22 X 1.6	
209	000-T00630-0B	M SCR TH BLK M6 X 30	
210	032-000430	WING BLT M4 X 30	
211	068-441616	FLT WSHR 4.4-16 X 1.6	

14 ASSY SUBCABI REAR (POD-1501)

(D-1/2)

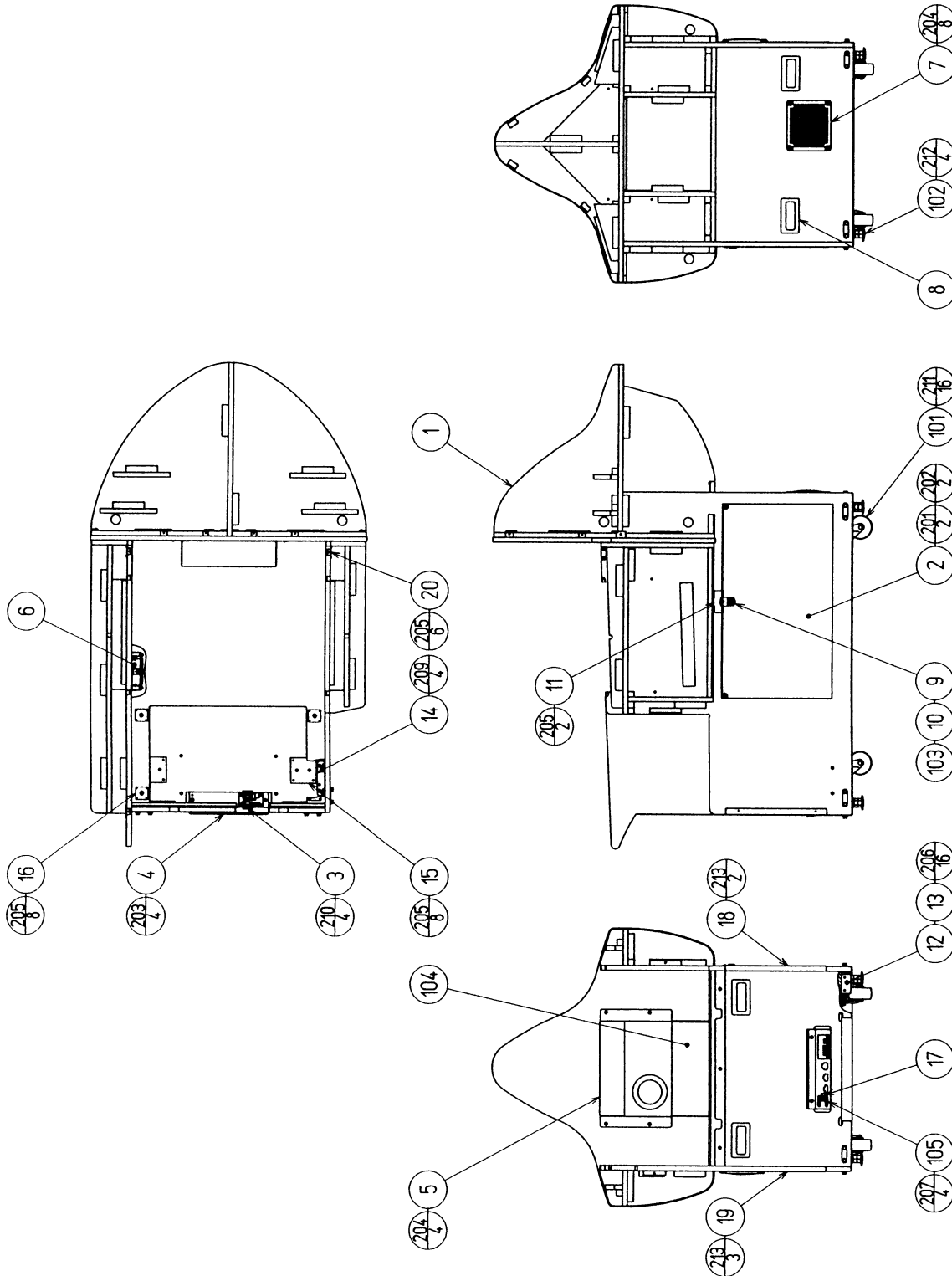

14 ASSY SUBCABI REAR (POD-1501)

(D-2/2)

ITEM NO.	PART NO.	DESCRIPTION	NOTE
1	POD-1502	REAR CABINET	
2	POD-1503	SIDE DOOR	
3	839-1176	CONN BD JVS & RGB	
4	POD-1507	CONN PANEL	
5	POD-1508	WOOFER BELT	
6	HOD-1530	FAN UNIT	
7	253-5460-01	AIR VENT BLACK	
8	253-5396-91	CABINET HANDLE	
9	DP-1148X	LKG TNG	
10	117-0062	PLATE LOCK RETAINER	
11	117-5098	TNG RETAINER PLATE	
12	ARC-1006	LEG BRACKET	
13	117-5233	PLATE LEG BRACKET BLACK	
14	POD-1008	NUT BRKT	
15	SCR-1008	NUT PLATE FOR CASTER	
16	DYN-2115	NUT PLATE M8	
17	421-11282	STICKER OPT CONN	
18	POD-1511	SASH L	
19	POD-1512	SASH R	
20	POD-1514	NUT BRKT M4	
101	601-9377	CASTER FAI=75	
	601-6224	CASTER 75	
102	601-5699X	LEG ADJUSTER BOLT M16 X 75	
103	220-5575	CAM LOCK MASTER W/O KEY	
104	130-5196-01	WOOFER 4OHM 80W W/NET	
105	211-5479-01	CONN OPT JOINT	
106	280-5207	HARNESS LUG CC-1005	
107	280-5277	CORD CLAMP 18	
108	601-0460	PLASTIC TIE BELT 100 MM	
109	280-5275-SR10	CORD CLAMP SR10	
201	000-T00430-0B	M SCR TH BLK M4 X 30	
202	068-441616-0B	FLT WSHR BLK 4.4-16 X 1.6	
203	000-P00416-W	M SCR PH W/FS M4 X 16	
204	000-T00420-0B	M SCR TH BLK M4 X 20	
205	011-T03512	TAP SCR TH 3.5 X 12	
206	030-000625-SB	HEX BLT W/S BLK M6 X 25	
207	000-P00312-W	M SCR PH W/FS M3 X 12	
208	011-F00316	TAP SCR FH 3 X 16	
209	000-P00520-W	M SCR PH W/FS M5 X 20	
210	000-P00320-W	M SCR PH W/FS M3 X 20	
211	030-000625-W	HEX BLT W/FS M6 X 25	
212	050-H01600-0B	HEX NUT BLK M16	
213	079-000008	SCR NAIL THH STNLS 1.5 X 16	
214	050-H00400	HEX NUT M4	
215	060-S00400	SPR WSHR M4	
216	060-F00400	FLT WSHR M4	
301	POD-6003	ASSY WIRE REAR CABI AC	
302	POD-6004	ASSY WIRE REAR CABI DC	
303	POD-60035	WIRE HARN SPEAKER	
305	600-6275-0150	ASSY FIBER CABLE 5 0150CM	



⑮ ASSY SEAT DX (POD-1600)

(D-2/2)

ITEM NO.	PART NO.	DESCRIPTION	NOTE
1	DYN-2131X	UPPER SEAT	
2	DYN-2132X	LOWER SEAT	
3	JBA-1603X	SEAT FRAME	
4	POD-1601	SEAT MOUNT TRAY	
5	POD-1602	SEAT BASE	
6	POD-1603	SEAT BACK COVER	
7	JBA-1605	SAFETY GUARD F	
8	JBA-1606	SAFETY GUARD R	
9	SPG-2410	PROTECT RUBBER	
10	SPG-2411	RUBBER PLATE	
101	601-9059-91	SEAT RAIL L	
102	601-9060-91	SEAT RAIL R	
201	030-000845-S	HEX BLT W/S M8 X 45	
202	030-000816-S	HEX BLT W/S M8 X 16	
203	000-T00408-0B	M SCR TH BLK M4 X 8	
204	050-H00800	HEX NUT M8	
205	060-S00800	SPR WSHR M8	
206	068-852216	FLT WSHR 8.5-22 X 1.6	
207	000-T00412-0B	M SCR TH BLK M4 X 12	
208	068-441616-0B	FLT WSHR BLK 4.4-16 X 1.6	
209	000-T00512-0B	M SCR TH BLK M5 X 12	



16 ASSY CONTROL PANEL (POD-2000)

(D-1/2)

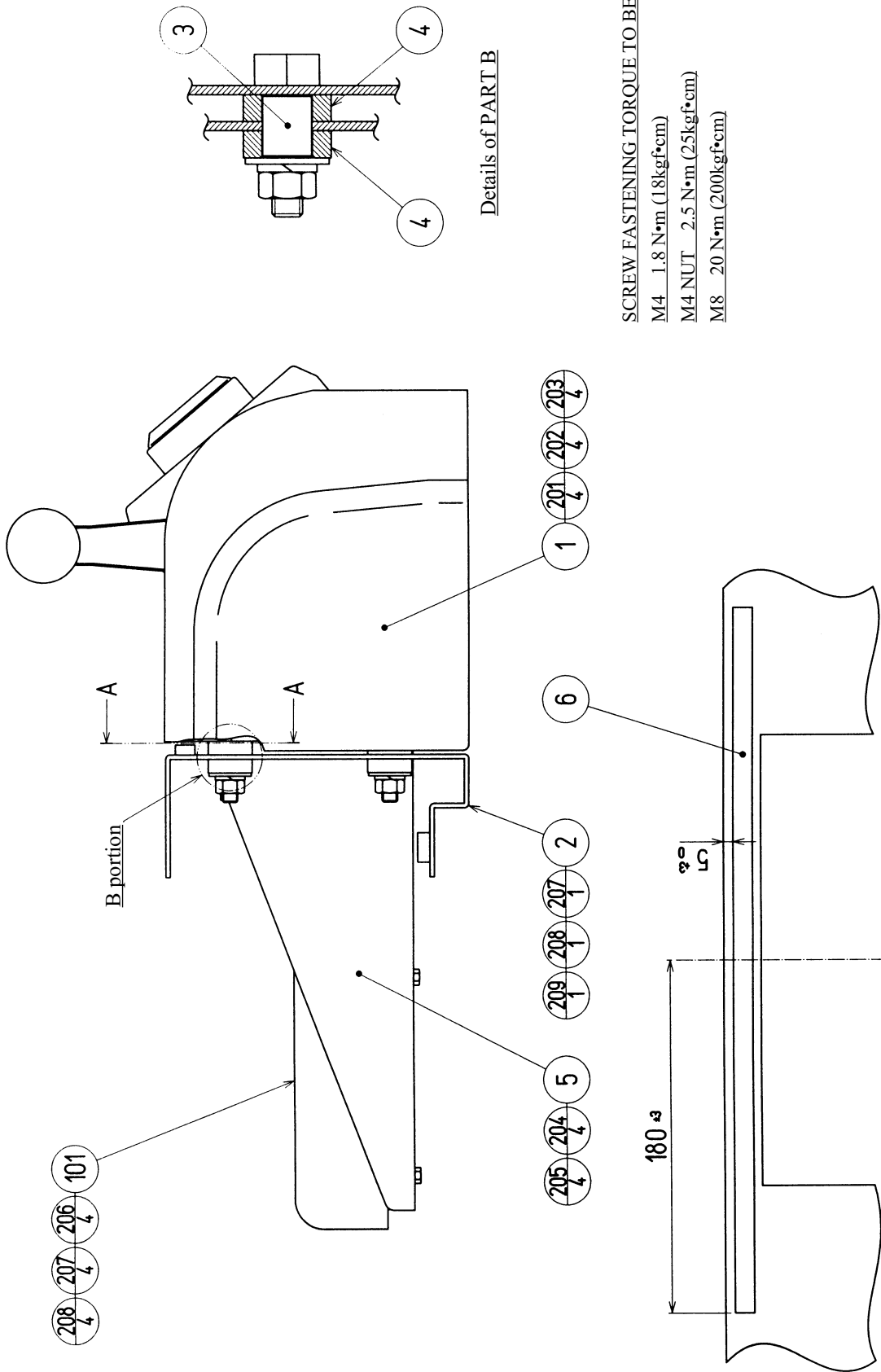

Details of PART B

SCREW FASTENING TORQUE TO BE  
 M4 1.8 N•m (18kgf•cm)  
 M4 NUT 2.5 N•m (25kgf•cm)  
 M8 20 N•m (200kgf•cm)

SECTION A-A

①6 ASSY CONTROL PANEL (POD-2000)

(D-2/2)

ITEM NO.	PART NO.	DESCRIPTION	NOTE
1	POD-2100	ASSY CONTROLLER	
2	POD-2001	CTRL PNL BASE	
3	POD-2002	COLLAR	
4	POD-2003	SPACER RUBBER	
5	POD-2004	SHAKER BRKT	
6	POD-2005	SPACER SPONGE	
101	130-5172	BASS SHAKER	
102	280-5169	CORD CLAMP TL-20S	
103	280-5009-01	CORD CLAMP 21	
104	601-0460	PLASTIC TIE BELT 100 MM	
201	050-H00800	HEX NUT M8	
202	060-S00800	SPR WSHR M8	
203	068-852216	FLT WSHR 8.5-22 X 1.6	
204	030-000820-S	HEX BLT W/S M8 X 20	
205	060-F00800	FLT WSHR M8	
206	000-F00414	M SCR FH M4 X 14	
207	050-H00400	HEX NUT M4	
208	060-S00400	SPR WSHR M4	
209	060-F00400	FLT WSHR M4	
301	POD-60029	WIRE HARN BASS SHAKER	

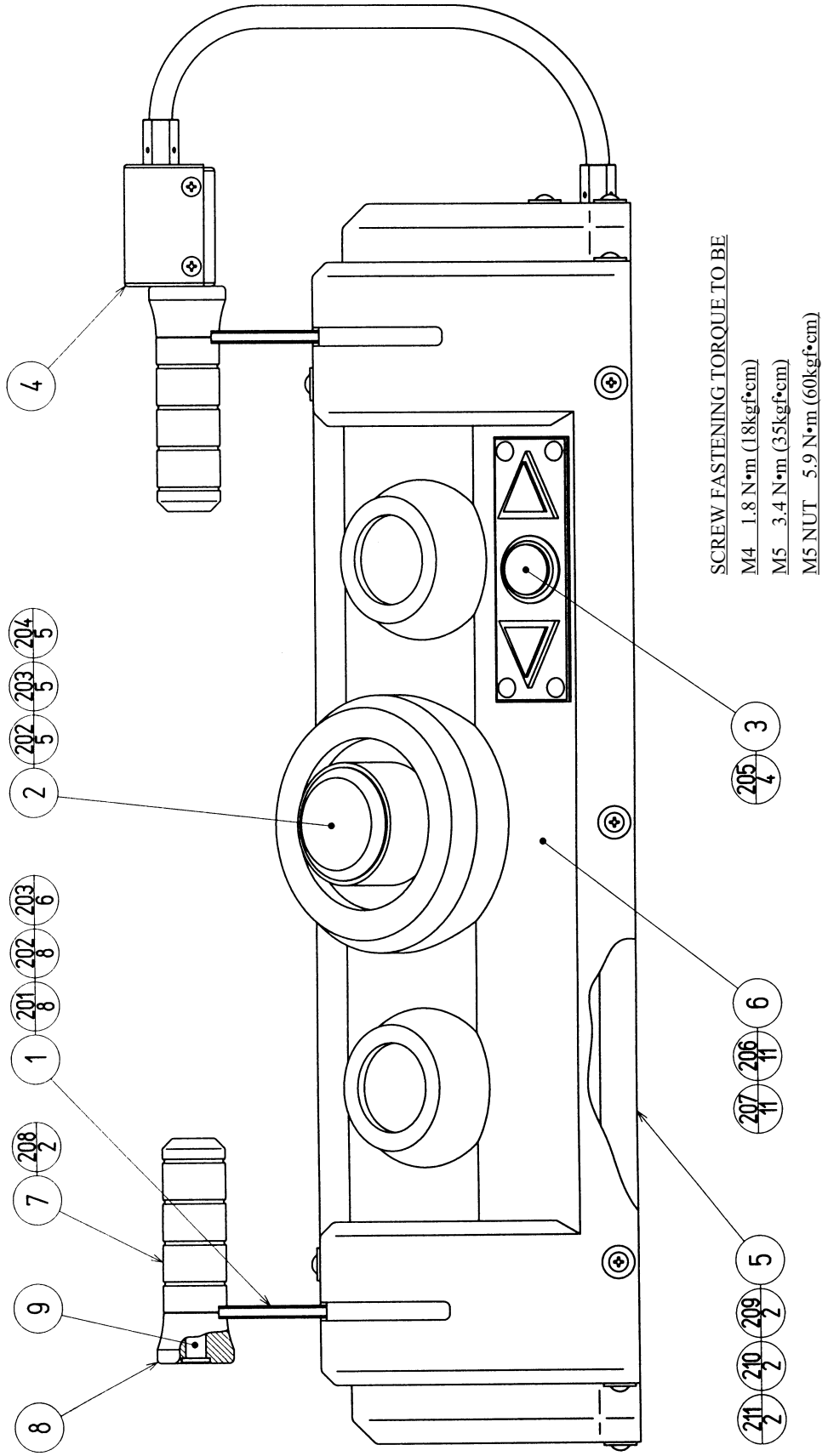

①7 ASSY CONTROLLER (POD-2100)

(D-2/2)

ITEM NO.	PART NO.	DESCRIPTION	NOTE
1	POD-2200	ASSY LEVER MECHA	
2	POD-2300	ASSY BOOST BUTTON	
3	POD-2400	ASSY START SW	
4	POD-2500	ASSY BRAKE	
5	POD-2101	CONTROLLER BASE	
6	POD-2102	CTRL PNL COVER	
7	POD-2103	GRIP	
8	POD-2104	GRIP END	
9	POD-2105	GRIP PIN	
101	280-5169	CORD CLAMP TL-20S	
102	280-5207	HARNESS LUG CC-1005	
103	280-5277	CORD CLAMP 18	
201	020-000512-HZ	HEX SKT CAP SCR BLK OZ M5 X 12	
202	060-S00500	SPR WSHR M5	
203	060-F00500	FLT WSHR M5	
204	050-H00500	HEX NUT M5	
205	000-T00412-0B	M SCR TH BLK M4 X 12	
206	000-T00408-0C	M SCR TH CRM M4 X 8	
207	068-441616-0C	FLT WSHR CRM 4.4-16 X 1.6	
208	000-P00430-WB	M SCR PH W/FS BLK M4 X 30	
209	050-H00400	HEX NUT M4	
210	060-S00400	SPR WSHR M4	
211	060-F00400	FLT WSHR M4	
212	050-F00400	FLG NUT M4	
213	010-P00306-F	S-TITE SCR PH W/F M3 X 6	
301	POD-60021	WIRE HARN ANALOG CTRL	
302	POD-60022	WIRE HARN BOOST SOL	
303	POD-60023	WIRE HARN I/O CTRL	

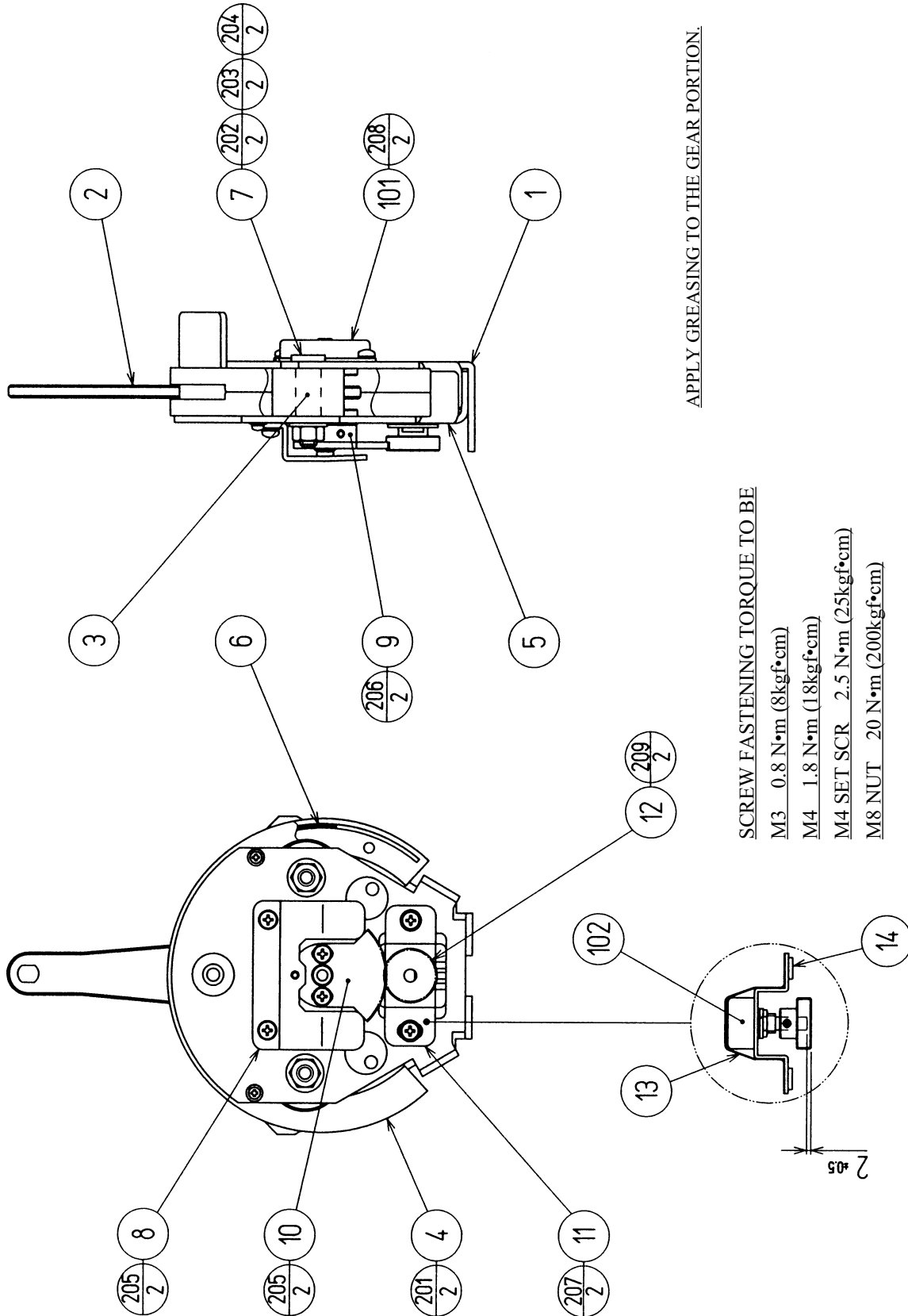

⑱ ASSY LEVER MECHA (POD-2200)

(D-2/2)

ITEM NO.	PART NO.	DESCRIPTION	NOTE
1	POD-2201	LEVER BRKT INNER	
2	POD-2202	LEVER SHAFT	
3	POD-2203	STOPPER RUBBER LEVER	
4	APC-3251	LEVER GUIDE	
5	APC-3253	LEVER BRKT OUTER	
6	APC-3255	SHUTTER PLATE	
7	APC-3257	STOPPER SHAFT LEVER	
8	APC-3258	Z BRKT	
9	TTR-2009	GEAR HOLDER 80	
10	601-6005	ADJUST GEAR	
11	APC-3209	VR BRKT LEVER INSU	
12	601-6555	GEAR Z=30 M=0.75	
13	APC-3208	INSULATOR PAPER LEVER	
14	APC-2014	INSULATOR BUSH	
101	601-10573-91	ROTARY DAMPER ROLL	
102	220-5484	VOL CONT B-5K OHM	
	220-5373	VOL CONT B-5K	
103	310-5029-D20	SUMITUBE F D 20 MM	
201	000-P00330-W	M SCR PH W/FS M3 X 30	
202	050-H00800	HEX NUT M8	
203	060-S00800	SPR WSHR M8	
204	060-F00800	FLT WSHR M8	
205	000-P00408-W	M SCR PH W/FS M4 X 8	
206	028-A00408-P	SET SCR HEX SKT CUP P M4 X 8	
207	000-P00412-W	M SCR PH W/FS M4 X 12	
208	000-P00408-S	M SCR PH W/S M4 X 8	
209	028-C00406-P	SET SCR CH CUP P M4 X 6	
301	POD-60024	WIRE HARN ANALOG	

19 ASSY BOOST BUTTON (POD-2300)

(D-1/2)

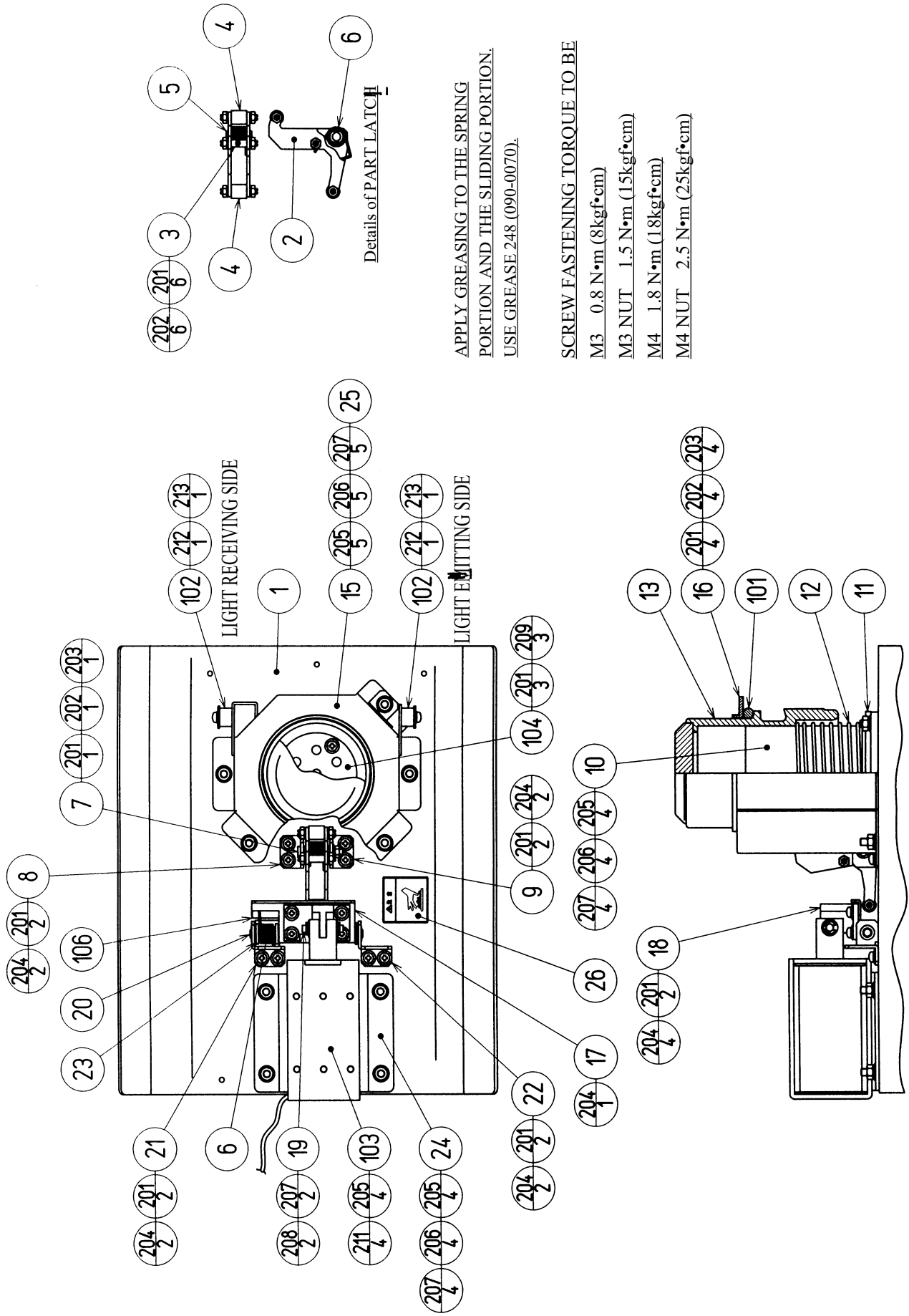

①9 ASSY BOOST BUTTON (POD-2300)

(D-2/2)

ITEM NO.	PART NO.	DESCRIPTION	NOTE
1	POD-2301	BOOST MECHA BASE	
2	POD-2302	LATCH ARM	
3	POD-2303	ROLLER PIN	
4	POD-2304	ROLLER	
5	POD-2305	LATCH COLLAR	
6	POD-2306	TOR SPRING BOOST	
7	POD-2307	LATCH PIN	
8	POD-2308	LATCH BRKT L	
9	POD-2309	LATCH BRKT R	
10	POD-2310	PIPE BASE	
11	POD-2311	STOPPER RUBBER BOOST	
12	POD-2312	COM SPRING	
13	POD-2327	BUTTON W/PLATE	
15	POD-2315	UPPER BASE	
16	POD-2316	BUTTON GUIDE	
17	POD-2317	RELEASE BRKT	
18	POD-2318	PLUNGER HOLDER	
19	POD-2319	PLUNGER PIN	
20	POD-2320	RELEASE PIN	
21	POD-2321	BEARING BRKT L	
22	POD-2322	BEARING BRKT R	
23	POD-2323	SPRING COLLAR	
24	POD-2324	SOLENOID BASE	
25	POD-2326	BLIND PLATE BOOST	
26	440-CS0149-EG	STICKER C HI TEMP M ENG	
101	601-10948	O-RING P-60	
102	370-5216	PHOTO SENSOR OMT-01DAMP	
103	124-5086-01	SOLENOID DC24V G-1577	
104	838-14051	LED BD POD	
105	280-5207	HARNESS LUG CC-1005	
106	601-6231-B015	EDGING NEW TYPE	
201	050-H00300	HEX NUT M3	
202	060-S00300	SPR WSHR M3	
203	060-F00300	FLT WSHR M3	
204	000-P00308-W	M SCR PH W/FS M3 X 8	
205	050-H00400	HEX NUT M4	
206	060-S00400	SPR WSHR M4	
207	060-F00400	FLT WSHR M4	
208	065-E00300	E RING 3MM	
209	000-P00330-W	M SCR PH W/FS M3 X 30	
210	090-0269	BOND	
211	000-P00412-W	M SCR PH W/FS M4 X 12	
212	000-P00312-S	M SCR PH W/S M3 X 12	
213	250-5421	FLT WSHR 3.5-12 T=1.0	
214	010-P00306-F	S-TITE SCR PH W/F M3 X 6	
301	POD-60025	WIRE HARN BOOST BUTTON	
302	POD-60026	WIRE HARN LED BD	



②① ASSY START SW (POD-2400)

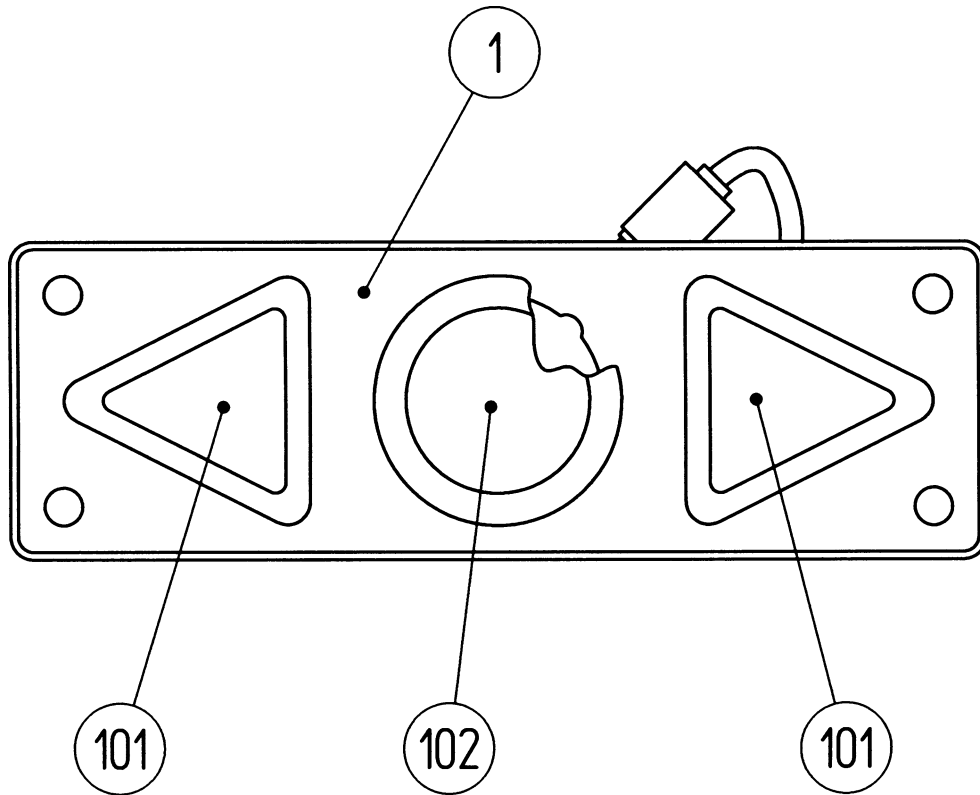

ITEM NO.	PART NO.	DESCRIPTION	NOTE
1	POD-2401	START SW PLATE	
101	509-5970-YE	SW PB OBSF-24TR YE	
102	509-5971-RE	SW PB OBSA-30UM W/L 6V3W RE	
103	601-0460	PLASTIC TIE BELT 100 MM	
301	POD-60028	WIRE HARN SW	

②① ASSY BRAKE (POD-2500)

(D-1/2)

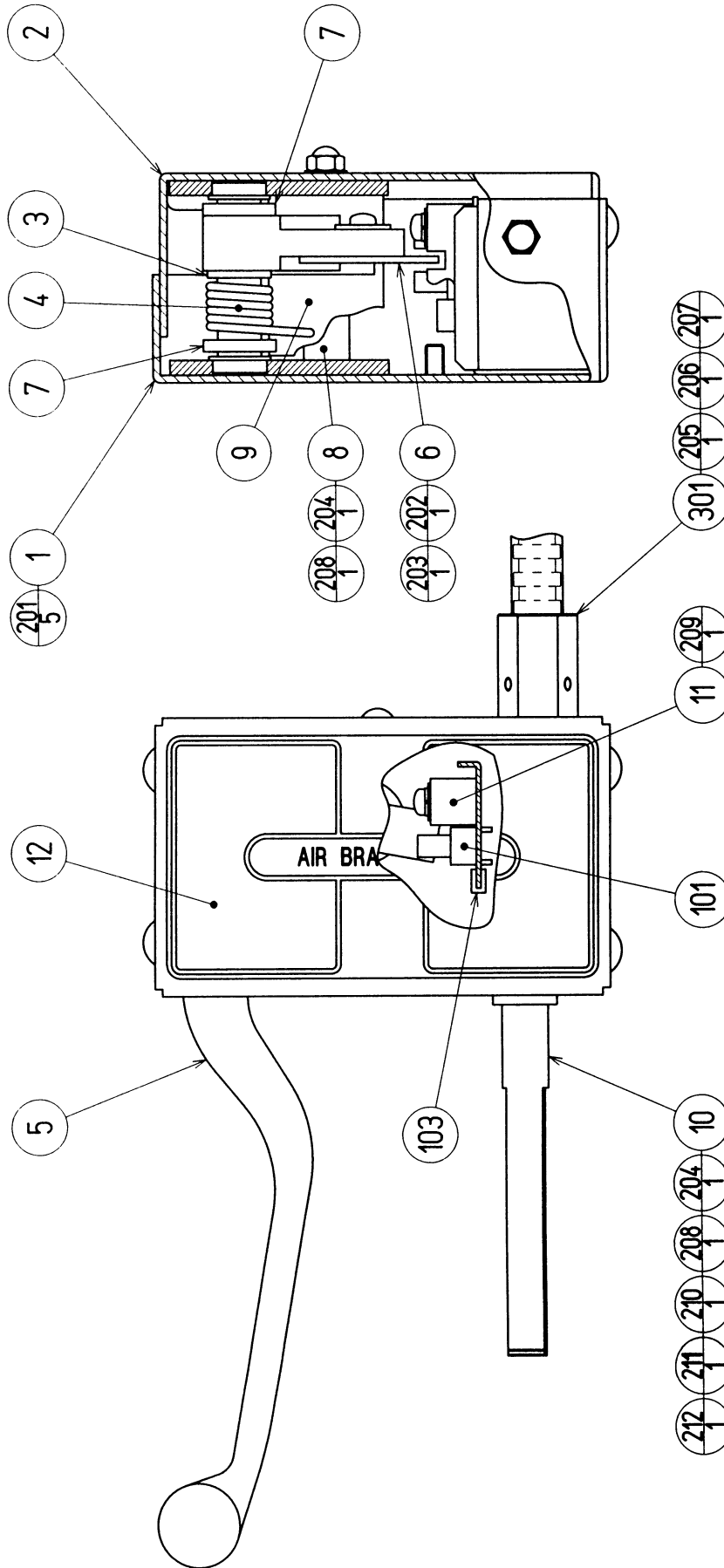

SCREW FASTENING TORQUE TO BE

- M3 0.8 N•m (8kgf•cm)
- M4 1.8 N•m (18kgf•cm)
- M4 NUT 2.5 N•m (25kgf•cm)

APPLY GREASING TO THE SPRING PORTION.

21 ASSY BRAKE (POD-2500)

(D-2/2)

ITEM NO.	PART NO.	DESCRIPTION	NOTE
1	POD-2501	BRAKE COVER UPPER	
2	POD-2502	BRAKE COVER LOWER	
3	POD-2503	BRAKE SHAFT	
4	POD-2504	TOR SPRING BRAKE	
5	POD-2505	BRAKE LEVER	
6	POD-2506	BLIND PLATE	
7	POD-2507	BRAKE COLLAR	
8	POD-2508	STOPPER SHAFT	
9	POD-2509	STOPPER RUBBER BRAKE	
10	POD-2510	GRIP PIN R	
11	POD-2511	SENSOR GUIDE	
12	POD-2512	STICKER BRAKE	
101	370-5161	PHOTO INTERRUPTER GP1A71A	
102	601-0460	PLASTIC TIE BELT 100 MM	
103	601-6231-A034	EDGING NEW TYPE (L=34MM)	
201	000-T00408-0B	M SCR TH BLK M4 X 8	
202	012-P00308	TAP SCR #2 PH 3 X 8	
203	250-5421	FLT WSHR 3.5-12 T=1.0	
204	050-C00400-3B	CAP NUT TYPE3 BLK M4	
205	050-H00400	HEX NUT M4	
206	060-S00400	SPR WSHR M4	
207	060-F00400	FLT WSHR M4	
208	060-F00400-0B	FLT WSHR BLK M4	
209	000-P00314-W	M SCR PH W/FS M3 X 14	
210	050-H01000	HEX NUT M10	
211	060-S01000	SPR WSHR M10	
212	060-F01000	FLT WSHR M10	
301	POD-60027	WIRE HARN BRAKE	

②② ASSY MAIN BD DX (POD-4000)

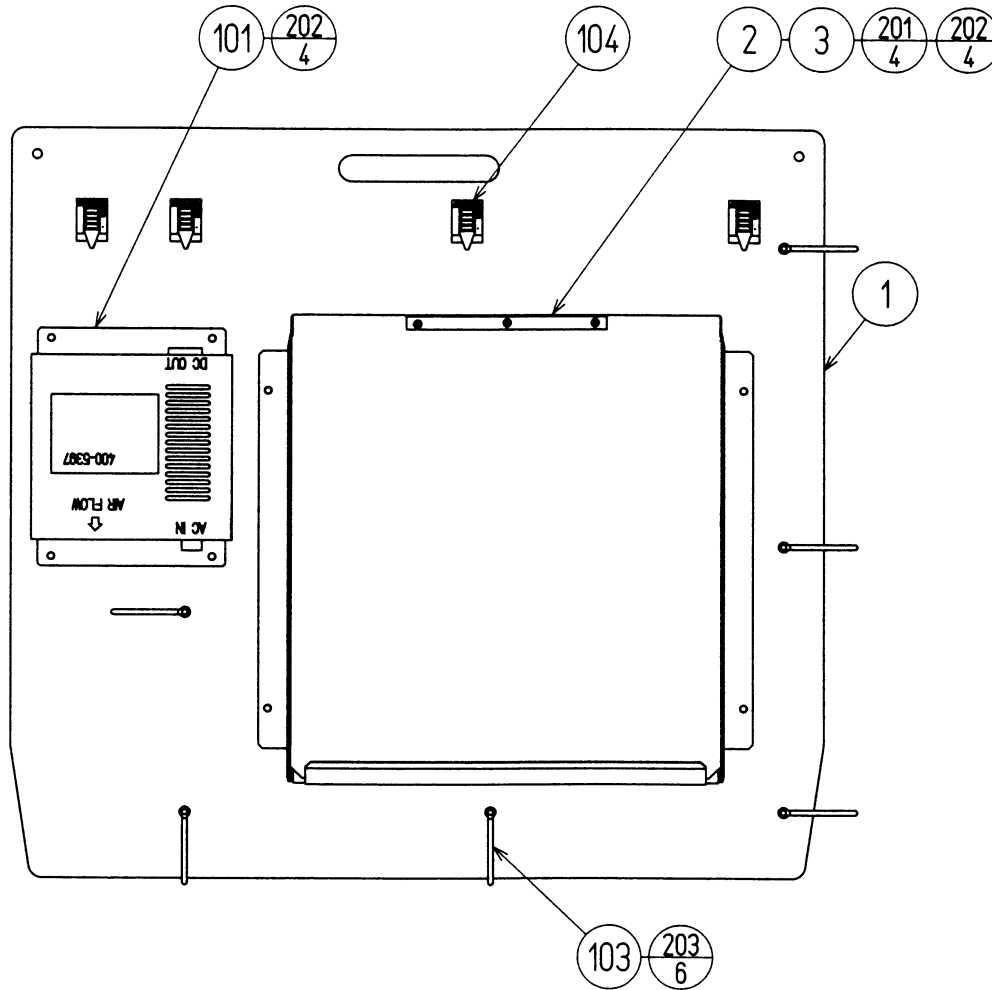

ITEM NO.	PART NO.	DESCRIPTION	NOTE
1	POD-4001	MAIN BD BASE	
2	POD-4050	ASSY SHIELD CASE POD	
3	105-5382	SHIELD CASE BRKT	
101	400-5397-01	SW REGU FOR JVS VA	
103	280-5207	HARNESS LUG CC-1005	
104	280-6600	CORD CLAMP TL-20W	
201	000-P00408-W	M SCR PH W/FS M4 X 8	
202	000-P00416-W	M SCR PH W/FS M4 X 16	
203	011-T03512	TAP SCR TH 3.5 X 12	
301	POD-60051	WIRE HARN AC IN	
302	POD-60052	WIRE HARN DC EXT	
303	POD-60053	WIRE HARN AUDIO OUT	
304	600-7159-020	WIRE HARN JVS PWR 020CM	

23 ASSY SHIELD CASE POD (POD-4050)

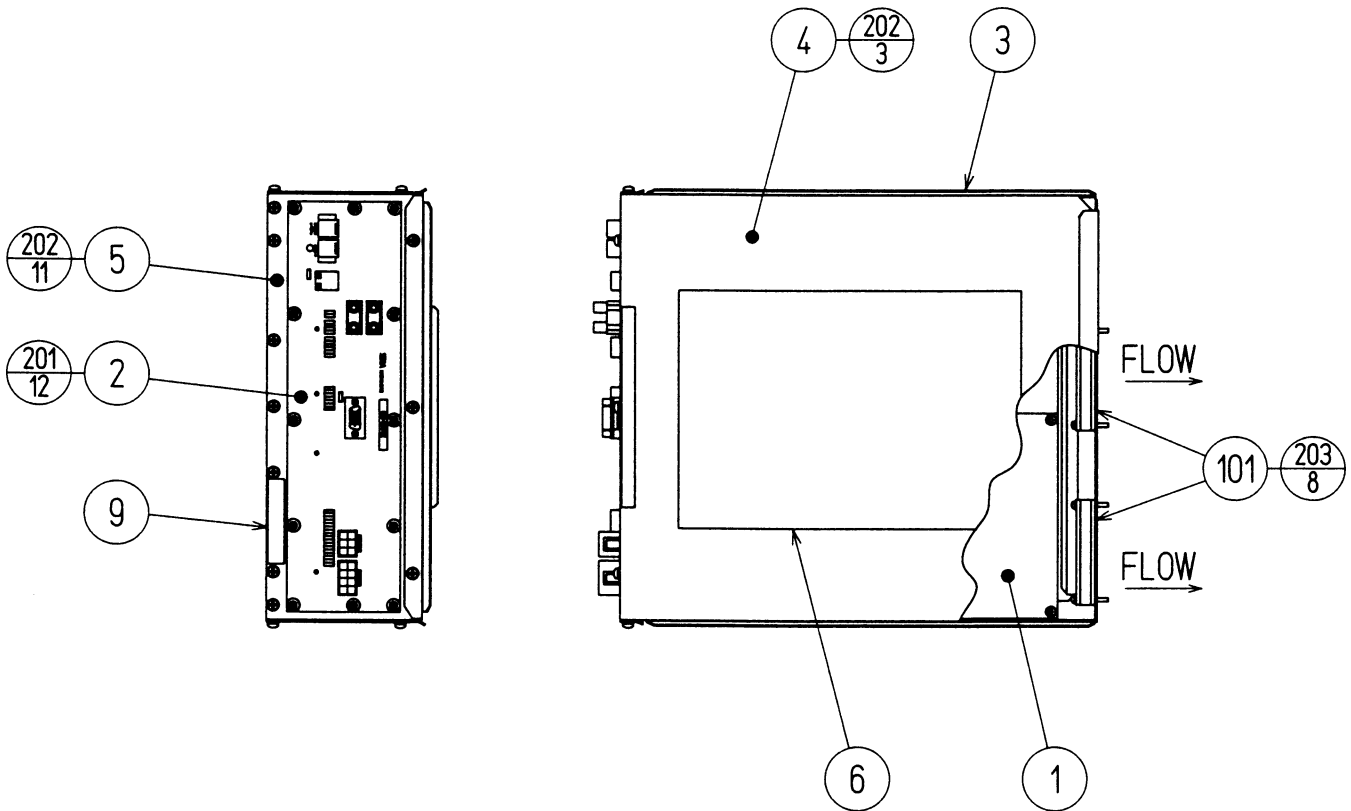

ITEM NO.	PART NO.	DESCRIPTION	NOTE
1	833-14003	GAME BD POD	
2	839-1079-02	FLT BD SEGA HIKARU NCR	
3	105-5378	SHIELD CASE FOR SEGA HIKARU	
4	105-5379	SHIELD CASE LID FOR SEGAHIKARU	
5	105-5381	FLT BD BRKT FOR SEGA HIKARU	
6	421-9174	STICKER CAUTION ANTISTATIC	
7	421-10023-AAB	STICKER BD SERIAL NUMBER AAB	
8	421-10023-BBP	STICKER BD SERIAL NUMBER BBP	
9	441-314003	STIKER 833-14003	
10	601-10642	CARTON BOX SEGA HIKARU	
101	260-0064	FAN MOTOR DC12V	
102	280-5275-SR10	CORD CLAMP SR10	
201	010-P00310-F	S-TITE SCR PH W/F M3 X 10	
202	000-P00408-W	M SCR PH W/FS M4 X 8	
203	000-P00325-W	M SCR PH W/FS M3 X 25	
301	FRQ-60037	WIRE HARN FAN SHIELD CASE	

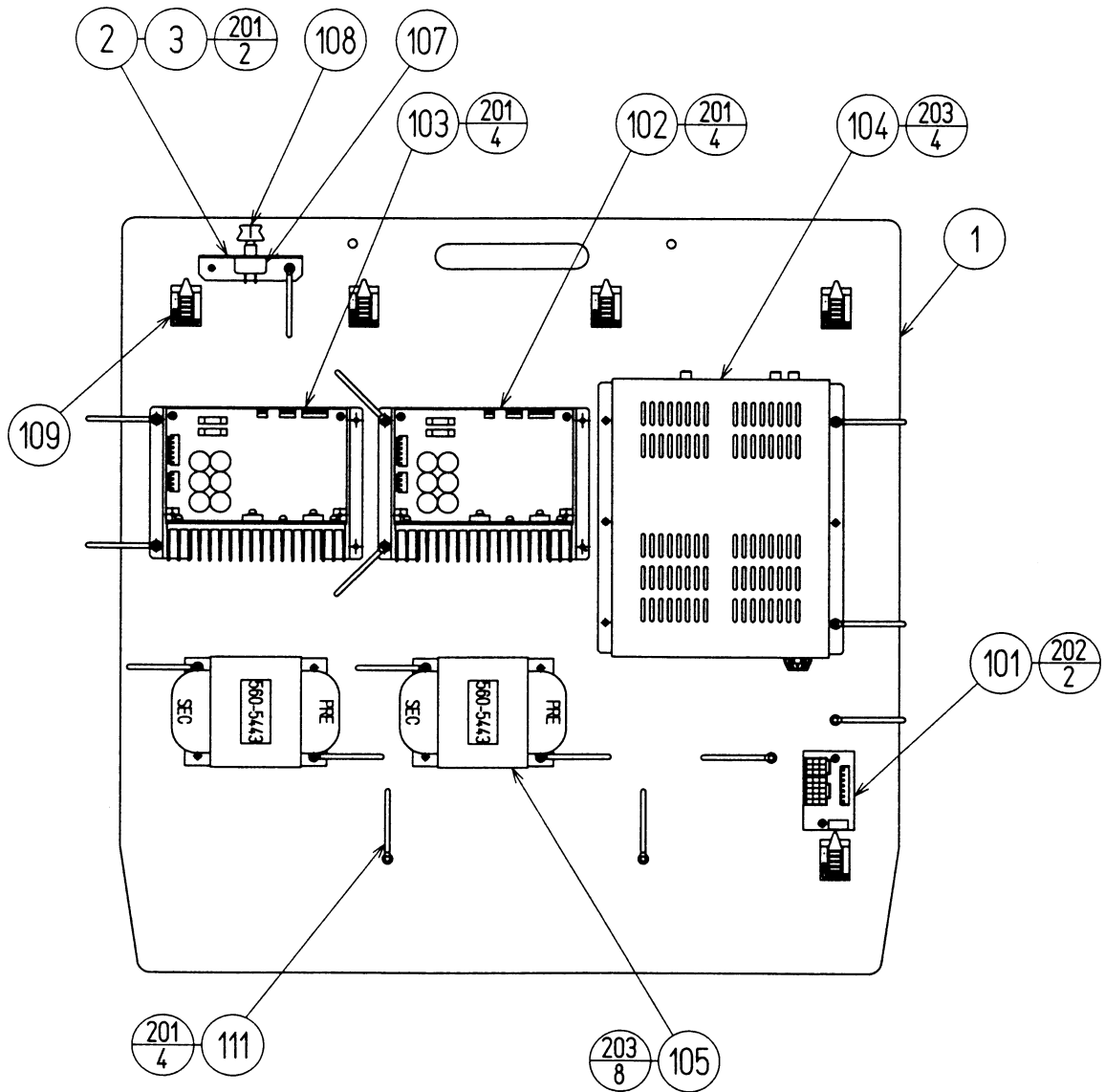

②4 ASSY SOUND BD DX (POD-4100)

(D-2/2)

ITEM NO.	PART NO.	DESCRIPTION	NOTE
1	POD-4101	SOUND BD BASE	
2	POD-4102	VR BRKT	
3	421-11275	STICKER VOLUME	
101	838-11856-UL	CONNECT BD UL	
102	838-13948	BASS WOOFER AMP 50WX1	
103	838-13948-01	BASS WOOFER AMP 50WX1	
104	601-10369	STEREO PWR AMP 47	
105	560-5443	AUDIO XFMR FOR 838-13948	
106	310-5029-D20	SUMITUBE F D 20 MM	
107	220-5179	VOL CONT B-5K OHM	
108	601-0042	KNOB 22 MM	
109	280-6600	CORD CLAMP TL-20W	
111	280-5207	HARNESS LUG CC-1005	
112	601-0460	PLASTIC TIE BELT 100 MM	
201	011-T03512	TAP SCR TH 3.5 X 12	
202	011-P00325	TAP SCR PH 3 X 25	
203	000-P00416-W	M SCR PH W/FS M4 X 16	
301	POD-60041	WIRE HARN AC IN	
302	POD-60042	WIRE HARN AC EXT	
303	POD-60043	WIRE HARN VOL	
304	POD-60044	WIRE HARN SPEAKER	
305	POD-60045	WIRE HARN AMP PWR	
306	POD-60046	WIRE HARN SOUND CENTER	
307	POD-60047	WIRE HARN SOUND	
308	POD-60048	WIRE HARN BASS VOL	

②5 ASSY CONTROL BD DX (POD-4200)

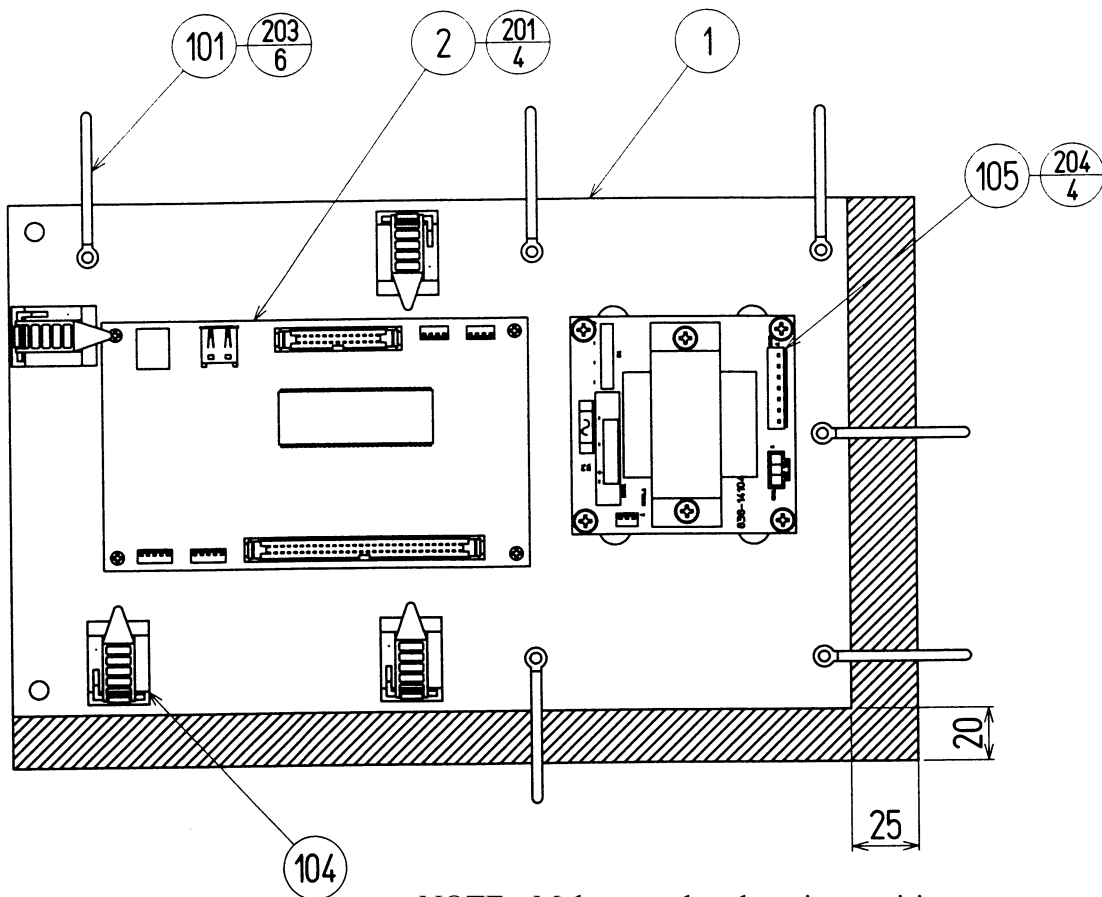

NOTE: Make sure that there is no wiring, etc. in the slash mark portions.

ITEM NO.	PART NO.	DESCRIPTION	NOTE
1	POD-4201	CONTROL BD BASE	
2	837-13551-92	I/O CONTROL BD FOR JVS	
101	280-5207	HARNESS LUG CC-1005	
103	601-0460	PLASTIC TIE BELT 100 MM	
104	280-6600	CORD CLAMP TL-20W	
105	838-14104	SSR BD AC100V IN DC24V OUT	
201	011-P00325	TAP SCR PH 3 X 25	
203	011-T03512	TAP SCR TH 3.5 X 12	
204	000-P00412-W	M SCR PH W/FS M4 X 12	
301	POD-60011	WIRE HARN RA60P	
302	POD-60012	WIRE HARN I/O BD PWR	
303	POD-60013	WIRE HARN SSR OUT	
304	POD-60014	WIRE HARN RA26P	
305	POD-60015	WIRE HARN AC IN	



## ②6 ASSY WIRE FRONT CABI (POD-6001)

ASSY WIRE FRONT CABI (POD-6001) is comprised of the following wire harnesses.  
An ASSY DRG. is unavailable.

ITEM NO.	PART NO.	DESCRIPTION	NOTE
101	601-0460	PLASTIC TIE BELT 100 MM	
301	POD-60003	WIRE HARN COIN CHUTE	
302	POD-60004	WIRE HARN DC EXT	
303	600-7009-1500	ASSY RGB CA D-SUB 15P 1500MM	
304	600-7141-200	CABLE JVS TYPE A-B 200CM	
305	600-6972-1950	WIRE HARN EARTH ID5 1950MM	
306	600-6972-2200	WIRE HARN EARTH ID5 2200MM	

## ②7 ASSY WIRE FRONT CABI I/O (POD-6002)

ASSY WIRE FRONT CABI I/O (POD-6002) is comprised of the following wire harnesses.  
An ASSY DRG. is unavailable.

ITEM NO.	PART NO.	DESCRIPTION	NOTE
1	601-0460	PLASTIC TIE BELT 100 MM	
301	POD-60005	WIRE HARN I/O EXT	
302	POD-60006	WIRE HARN SOL EXT	
303	POD-60007	WIRE HARN ANALOG EXT	

②⑧ ASSY WIRE REAR CABI AC (POD-6003)

ASSY WIRE REAR CABI AC (POD-6003) is comprised of the following wire harnesses.  
An ASSY DRG. is unavailable.

ITEM NO.	PART NO.	DESCRIPTION	NOTE
1	601-0460	PLASTIC TIE BELT 100 MM	
301	POD-60031	WIRE HARN AC EXT	
302	POD-60034	WIRE HARN AC FAN	

②⑨ ASSY WIRE REAR CABI DC (POD-6004)

ASSY WIRE REAR CABI DC (POD-6004) is comprised of the following wire harnesses.  
An ASSY DRG. is unavailable.

ITEM NO.	PART NO.	DESCRIPTION	NOTE
1	601-0460	PLASTIC TIE BELT 100 MM	
301	POD-60032	WIRE HARN SOUND EXT	
302	POD-60033	WIRE HARN DC EXT	
303	600-7009-1500	ASSY RGB CA D-SUB 15P 1500MM	
304	600-7141-150	CABLE JVS TYPE A-B 150CM	

③ ASSY TRANS 100-120V (POD-4300)

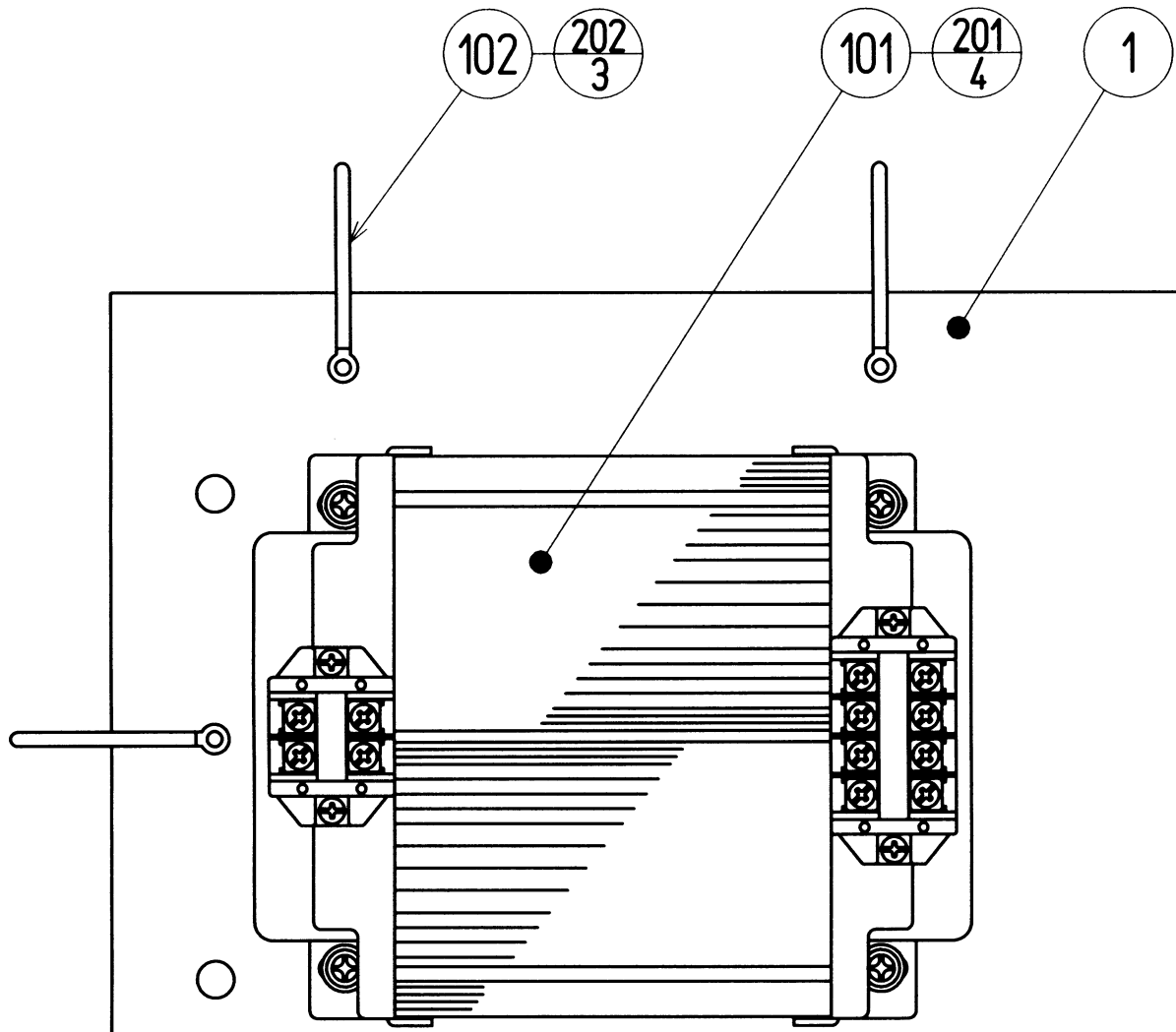

ITEM NO.	PART NO.	DESCRIPTION	NOTE
1	POD-4301	TRANS BASE	
101	560-5384	XFMR 100-120V 100V 10A WB	
102	280-5207	HARNESS LUG CC-1005	
201	000-P00516-W	M SCR PH W/FS M5 X 16	
202	011-T03512	TAP SCR TH 3.5 X 12	
301	POD-60072	WIRE HARN XFMR IN	
302	POD-60073	WIRE HARN XFMR OUT	



# 20. WIRE COLOR CODE TABLE

THE WIRE COLOR CODE is as follow:

- A PINK
- B SKY BLUE
- C BROWN
- D PURPLE
- E LIGHT GREEN

Wires other than those of any of the above 5 single colors will be displayed by 2 alphanumeric characters.

- 1 RED
- 2 BLUE
- 3 YELLOW
- 4 GREEN
- 5 WHITE
- 7 ORANGE
- 8 BLACK
- 9 GRAY

If the right-hand side numeral of the code is 0, then the wire will be of a single color shown by the left-hand side numeral (see the above).

Note 1: If the right-hand side alphanumeric is not 0, that particular wire has a spiral color code. The left-hand side character shows the base color and the right-hand side one, the spiral color.

<Example> 51 ..... WHITE / RED

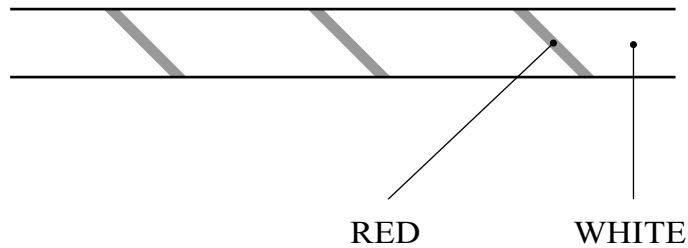

Note 2: The character following the wire color code indicates the size of the wire.

- U: AWG16
- K: AWG18
- L: AWG20
- None: AWG22

## **Warranty**

Your new Sega Product is covered for a period of 90 days from the date of shipment. This certifies that the Printed Circuit Boards, Power Supplies and Monitor are to be free of defects in workmanship or materials under normal operating conditions. This also certifies that all Interactive Control Assemblies are to be free from defects in workmanship and materials under normal operating conditions. No other product in this machine is hereby covered.

Sellers sole liability in the event a warranted part described above fails shall be, at its option, to replace or repair the defective part during the warranty period. For Warranty claims, contact your Sega Distributor.

Should the Seller determine, by inspection that the product was caused by Accident, Misuse, Neglect, Alteration, Improper Repair, Installation or Testing, the warranty offered will be null and void.

Under no circumstances is the Seller responsible for any loss of profits, loss of use, or other damages.

This shall be the exclusive written Warranty of the original purchaser expressed in lieu of all other warranties expressed or implied. Under no circumstance shall it extend beyond the period of time listed above.



**SEGA ENTERPRISES, INC. (USA)**

45133 Industrial Drive  
Fremont, CA 94538  
**(415) 701-6580** phone  
**(415) 701-6594** fax